

EXTERNAL CLADDING & EAVES LINING

FC:121



EXTERIOR CLADDING SYSTEM

JULY 2011

A fast, simple, durable and attractive external cladding system for residential walls, ceilings and eaves.

cemintel™
fibre cement systems



CSR

CONTENTS

Description	2
Applications	2
Advantages	2
Material Properties	2
Components	3 – 4
Design Considerations	4 – 5
Handling and Storage	6
Sheet Preparation	6
Installation – Wall Cladding	7 – 9
Installation – Ceilings & Eaves	10 – 11
Decoration	11
Health & Safety	12
Guarantee	12
Contacts	12

DESCRIPTION

Cemintel™ Cladding Sheet and Cemintel™ Eaves Lining Sheet are autoclaved, cellulose fibre reinforced cement sheets with a smooth flat surface. Joint treatments include PVC moulds and timber cover strips, and the sheets are required to be paint finished.

Cladding and Eaves Lining Sheets conform to the requirements of AS2908.2 – Cellulose-cement products Part 2: Flat sheets. They are immune to water damage and will not rot.

APPLICATIONS

Cemintel™ Cladding Sheets are designed for use as external wall cladding for residential buildings, in locations such as verandas, gables, garages and upper storey additions. They can also be used for exterior ceilings and eaves. Cemintel™ Eaves Lining Sheets are conveniently sized for use in the lining of eaves.

Cladding and Eaves Lining Sheets are suitable for buildings in wind classifications up to N3 and for use with timber framing. They may be used to meet the requirements of some Bushfire Attack Levels. Refer to Cemintel™ manual Construction Guide for Bushfire Areas.

ADVANTAGES

- Smooth surface finish on face of sheet easily accepts exterior paint finishes.
- Simple and quick to install using standard building methods.
- Immune to permanent water damage.
- Will not rot.
- Low maintenance.
- High durability exterior grade material.
- Fire resistant.
- Termite resistant.

MATERIAL PROPERTIES

MANUFACTURING TOLERANCES

Cladding Sheet 6mm thickness (nominal)	9.5kg/m ²
Eaves Lining Sheet 4.5mm thickness (nominal)	7.0kg/m ²
Sheet Width	+0, -3mm
Sheet Length	+0, -4mm
Sheet Thickness	+0.5, -0mm
Diagonal Difference	3mm

FIRE RESISTANCE

In accordance with the Building Code of Australia, Part 3.7.1.2, Cemintel™ fibre cement sheets can be used wherever non-combustible material is required by the code.

Early Fire Hazard Indices for Cladding Sheet and Eaves Lining Sheet are:

Ignitability	0
Spread of Flame	0
Heat Evolved	0
Smoke Developed	0
Group Number	1
Average Specific Extinction Area	<250m ² /kg

COMPONENTS

CEMINTEL™ CLADDING SHEET

Cemintel™ Cladding Sheet is available in 6mm thickness and a range of sizes. Sheets are supplied with a slightly bevelled edge on all four sides for ease of insertion into the plastic joining strips.

Sheet Length (mm)	Width 900 mm	Width 1200 mm
1800	X	✓
2400	✓	✓
2700	X	✓
3000	X	✓

CEMINTEL™ EAVES LINING SHEET

Cemintel™ Eaves Lining Sheet is available in 4.5mm thickness and a range of sizes to suit common eaves widths. Sheets are supplied with square edges.

Sheet Length (mm)	Width 450mm	Width 600mm	Width 750mm
2400	✓	✓	✓

FASTENERS

Cemintel™ Fibre Cement Nails:

Galvanised 2.8mm x 30mm for softwood and hardwood timber framing.



Order No	Nail	Pack Size
77226	2.8 x 30mm	2.5kg

Note: Stainless steel nails (supplied by others) are required for high corrosion zones.

Cemintel™ Fibre Cement Screws – For Ceilings and Eaves with Timber Framing

For 6mm thickness sheet:

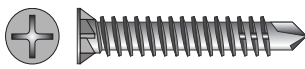
- 30mm FibreZIPS Class 3 self embedding head screws. 

For 4.5mm and 6mm thickness sheets:

- N° 8 x 30mm Class 3 wafer head screws 

Order No	Screw	Pack Size
13165	N° 9-18 x 30mm FibreZIPS CSK	1000
28625	N° 8 x 30mm Wafer head	1000

Note: Class 4 screws (supplied by others) are required for high corrosion zones

PVC JOINING STRIPS

PVC extrusions can be used for for sheet joining and edge finishing. Joining Strips have an extended leg to enable concealed fixing of the profile to the supporting frame.

PVC H Mould		
Order No	Size	Length
11264	4.5mm	2.4
11266	4.5mm	3.0
11255	6.0mm	3.0

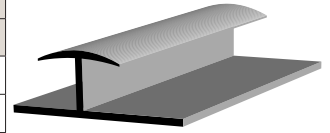

PVC Cap Mould		
Order No	Size	Length
11387	4.5mm	3.0
11384	6.0mm	3.0

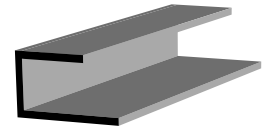

PVC Internal Corner		
Order No	Size	Length
11330	4.5mm	3.0
11327	6.0mm	3.0

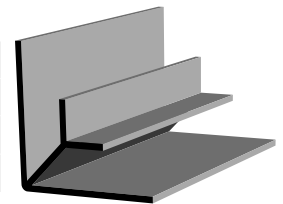

PVC External Corner		
Order No	Size	Length
11195	4.5mm	3.0
11194	6.0mm	3.0

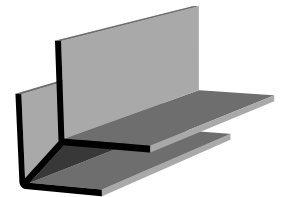

PVC Cover Strip		
Order No	Size	Length
11190	6 x 38mm	3.0



PVC Corner Angle Mould		
Order No	Size	Length
11176	4 x 47 x 47mm	3.0

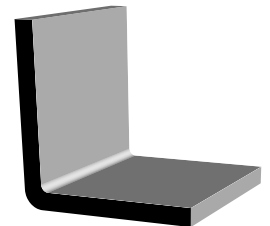

CORNER FLASHING

PVC Angle weatherproofing used over sarking at internal and external corners.

Product	Order N°
50 x 50 x 2400mm PVC Angle	11205

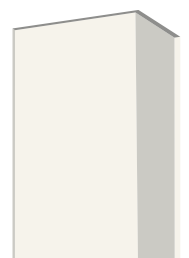

SARKING

Bradford foil products are used to provide thermal insulation and moisture protection. Thermofoil 733 is a double reflective foil for high thermal rating.

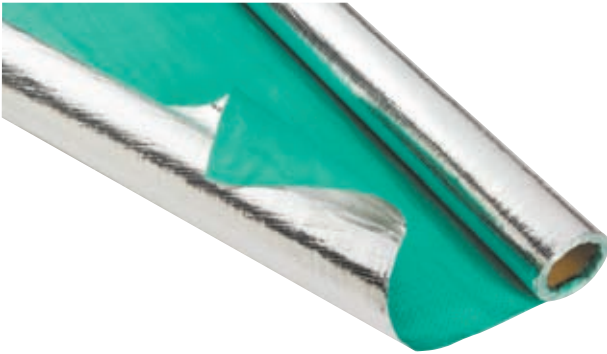

Bradford Product	Vapour Barrier Classification	Quantity	Order N°
EnviroSeal™ Wall Wrap	Medium	1350mm x 60m roll	10576
EnviroSeal™ Wall Breather	Low	1350mm x 60m roll	18666

INSULATION

Bradford products are used to provide insulation to meet required thermal rating.



DESIGN CONSIDERATIONS

SYSTEM DESIGN

Exterior walls and ceilings are subject to wind loads and the design of framing and fixings must be based on the project's site conditions. Fixing requirements are provided for Wind Classifications N1 to N3 for buildings that come within the scope of AS 4055: Wind Loads for Housing. Factors that affect the classification include the wind speed region, the terrain category in the vicinity of the site, and shielding from nearby buildings. Local pressure factors also apply to parts of the building.

It is the responsibility of the building designer to determine the applicable Wind Classification for the building.

FRAMING

Cladding and Eaves Lining Sheet should be fixed to timber framing that has been designed in accordance with AS1684 – Residential Timber-Framed Construction, and maximum stud spacings as specified in the Installation section.

Timber shall be seasoned or have reached an equilibrium moisture content of 16% or less at the time of framing. Unseasoned timber is not recommended as it is prone to shrinkage and warping.

TERMITE PROTECTION

As there is a wide variety of methods for managing termite entry to buildings, and selecting the appropriate method for any structure depends on specific risk factors and the form of construction, measures for termite management have not been addressed in this guide. Refer to your local pest management service, the BCA, AS3660, or your local building authorities for more information about the requirements for the design of a suitable termite management system.

SARKING

It is a requirement that sarking is used for walls clad with Cemintel™ Cladding Sheet. Wind forces can produce lower air pressures within buildings than on the outside, assisting to force water through gaps in the building envelope such as around penetrations and joint locations, even at low wind speeds.

Sarking must be designed and installed in accordance with AS/NZS4200 Part 1: Materials, and Part 2: Installation Requirements. Recommended products are Bradford Enviroseal Wall Breather (Low vapour transmission resistance) and Enviroseal Wall Wrap (Medium vapour transmission resistance).

Condensation is a complex problem, and can occur under a variety of conditions, not just cold weather. Literature on this subject is available from CSIRO/BRANZ/ASHRAE and should be consulted when building in areas where condensation is likely to occur. In these cases, the appropriate use of a sarking as a vapour barrier or as thermal insulation, or both, can be effective in controlling condensation.

COLD CLIMATES

In cold climates where condensation in the wall cavity is possible, a vapour barrier is also recommended between the internal linings and the framing.

Cemintel™ Cladding Sheets are not designed to be in contact with snow or ice for extended periods, such as is experienced in alpine areas subject to snow drifts.

COASTAL AREAS

Fixings used with Cladding and Eaves Lining Sheets may not be suitable for use in coastal areas, defined as up to 1km from a surf beach, or less than 50m from a shore without breaking surf. Consideration must also be given to local weather and topographical features that can cause an increase in the distance that salt spray can travel beyond these limits, extending the coastal area. Check with fixing manufacturers for alternative fixings that are suitable for use in coastal and other corrosive areas.

In these areas, walls must be sufficiently exposed from above so that rain can perform natural wash down of the wall. Walls that are protected by soffits above must be washed down twice per year, to remove salt build-up.

Prior to the application of external coatings, wash down walls with clean fresh water to remove salt spray build-up from sheets and fixings. Sheets must be allowed to dry before coating.

INSULATION

It is recommended that insulation materials be installed for energy conservation and occupant comfort. Insulation also improves the acoustic performance of the wall against outside noise.

The level of insulation provided in a wall is described by its total R-value. The higher the R-value the greater the insulation provided.

R-values for some systems have been calculated in accordance with the methods of the BCA and are given in Table 1: Insulation Details.

Energy efficiency requirements for buildings are set out in the BCA as performance requirements and acceptable construction practices, and are dependant on geographical climate zones. To meet the requirements, it is recommended that CSR Bradford insulation be installed in the wall framing. Check with local building authorities for minimum insulation requirements.

WINDOW SELECTION

The cladding system is designed to accept standard aluminium or timber framed windows. Aluminium windows **MUST NOT** have sill drain holes which can direct water behind the cladding. Windows with face draining format **MUST** be used.

Jamb flashing is required in all cases, and for ease of installation, these should be included when ordering windows.

The cladding system can accept many standard window types. One example is provided on page 16 of this guide. Other window types can be installed in a similar manner by varying the timber reveal depth to suit the overall wall thickness.

Window Drainage

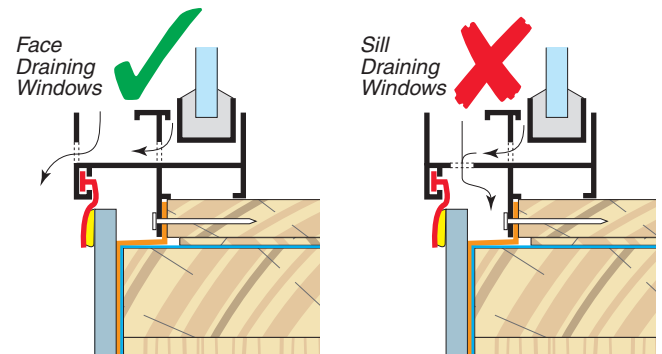

Table 1: Insulation Selection

CEMINTEL CLADDING SHEET				
<ul style="list-style-type: none"> • 1 layer Cemintel™ External Cladding Sheet to the outside of wall framing. • Timber Studs 90mm at 600mm maximum centres. • Wall wrap and insulation as per table below. • 1 layer x 10mm GYPROCK™ Plasterboard CD to the inside of framing. 				
Insulation	Sarking	Winter Total Wall R-Value	Summer Total Wall R-Value	
(a) BRADFORD 75mm Gold Wall Batts R1.5	BRADFORD ENVIROSEAL Wall Wrap	1.82	1.6	
(b) BRADFORD 90mm Gold Wall Batts R2.0	BRADFORD ENVIROSEAL Wall Wrap	2.3	2.1	

NOTES:
Values are sourced from ICANZ Handbook (W0211).

HANDLING & STORAGE

All Cemintel™ fibre cement sheeting should be kept dry, preferably by being stored inside the building. Where it is necessary to store sheets outside, they should be stacked flat, off the ground, properly supported on a level platform and protected from the weather.

Care should be taken to avoid damage to edges, ends and surfaces. If sheets become wet, allow to dry thoroughly before fixing.

SHEET PREPARATION

CUTTING

Tungsten Tipped Score and Snap Knife

1. Score face of sheet 4 to 5 times using a tungsten tipped knife against a straight edge.
2. Support the scored edge with the straight edge and snap the sheet upwards for a clean break.

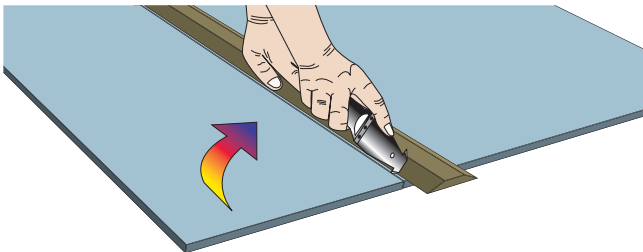

Hand Guillotine

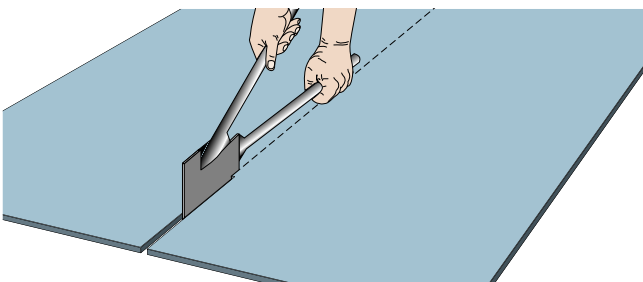

Hand Saw: Work with sheet face up to prevent burrs forming on the face.

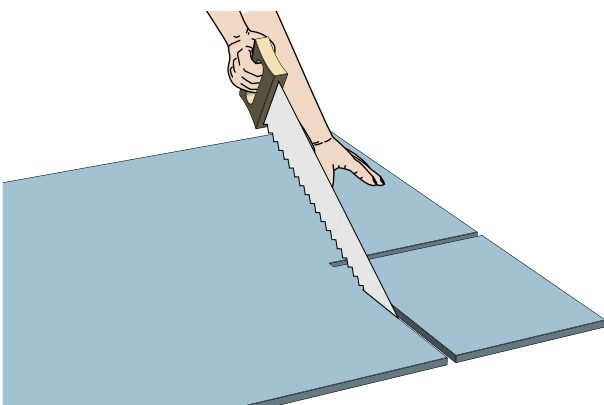

HOLE FORMING

Small holes are formed by:

1. Drilling a number of holes around the perimeter of the opening to be formed.
2. Support edge of opening to minimise damage to sheet, and use a hammer to carefully tap out the centre.

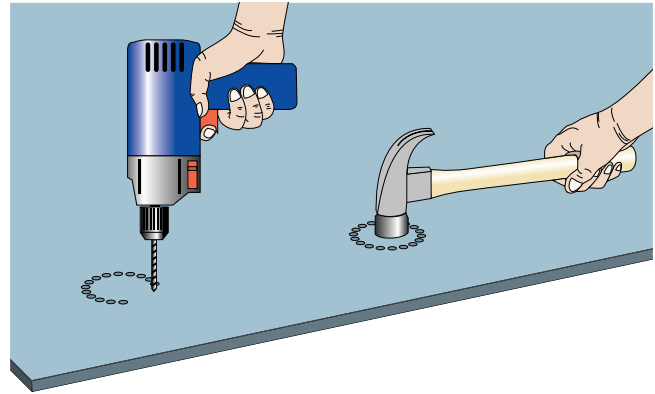

Large holes or openings are formed by:

1. Scoring around the perimeter of the opening.
2. Form a large hole in the centre as noted above.
3. Saw cut from the hole to the corners of the opening.
4. Support edges and snap away off cuts.

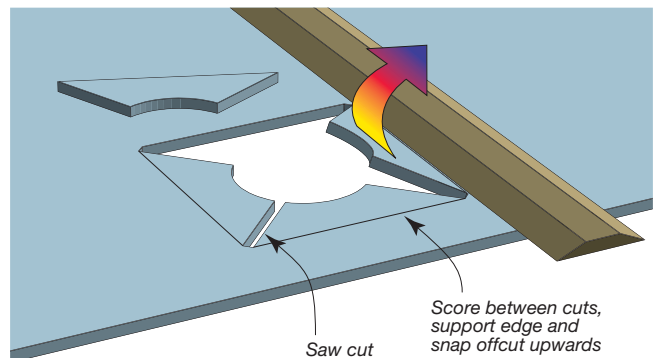

Power Saw

When it is necessary to use power tools for cutting Cemintel™ sheets, CSR recommends using the Hitachi Fibre Cement Power Saw Blade. This blade is specifically designed for use with fibre cement and produces a superior cut compared to conventional blades.

It is ideal for use with the Hitachi C7YA dustless circular saw and other 185mm circular saws fitted with vacuum extraction systems.



Product	Order N°
Hitachi C7YA Dustless Circular Saw	10836
Hitachi Dust Extractor	10833
Hitachi Fibre Cement Power Saw Blade	10837

INSTALLATION – WALL CLADDING

Inspect the frame carefully for bowed, warped, or twisted studs, and for alignment of all framing members, including noggings. Check alignment of all framing with a long straight-edge. The maximum misalignment should not exceed 4mm over 3000mm, 3mm over 1200mm or 2mm over 600mm, when checked both horizontally and vertically. Ensure all noggings are flush.

Studs must have a minimum fixing face width of 42mm to provide sufficient support for nailing. Otherwise, an additional stud or trimmer may be used to ensure fasteners have suitable edge distances. Stud spacing is to be spaced at maximum 600mm centres and to coincide with sheet widths.

FIG 1: Installation Detail for Narrow Stud Application

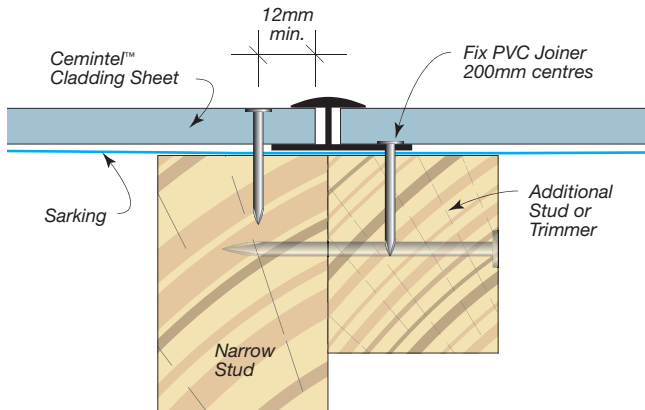

Sheets must be fixed vertically, and horizontal sheet joints are not permitted.

Joints between Cladding Sheets should always coincide with a supporting framing member, and all edges must be supported at openings. Correct design of the framework and careful consideration of the sheet can minimise the number of joints, and will contribute to the long term performance of the wall.

Fasteners are to be positioned as detailed in Table 2, and are to be applied in accordance with the chosen sheet joining method. Fasteners must be positioned a minimum of 12mm from sheet edges and 50mm from sheet corners. Nail heads may be driven flush or hard to the sheet surface.

FIG 2: Fixing of Wall Sheets to Framing

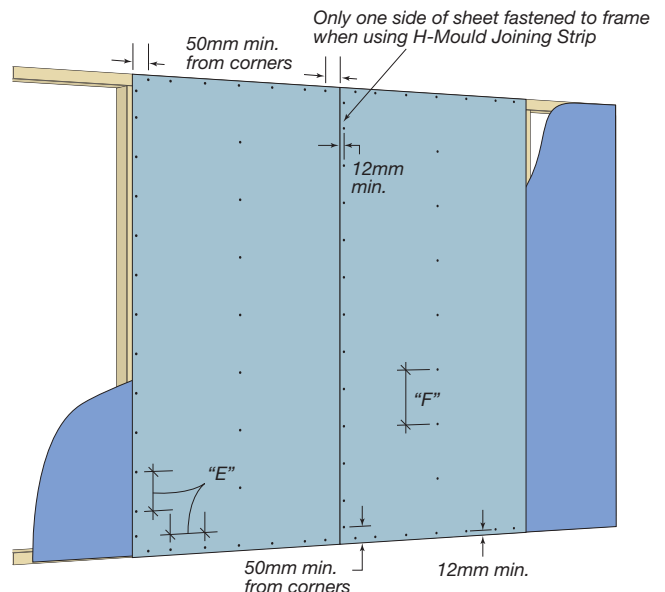

FIG 3: Fastener Driving

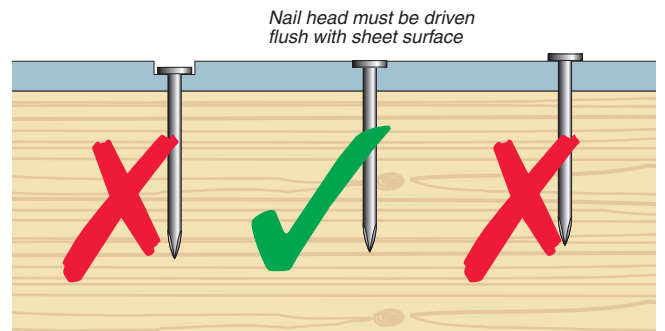

FIG 4: Base Detail

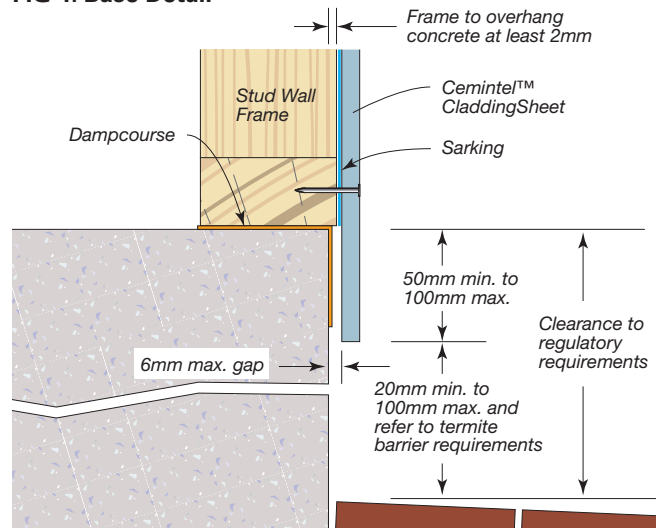

Table 2: Stud and Fastener Spacing – 6mm Cladding Sheet to Walls

Wind Classification	Within 1.2m of Building Corner			Elsewhere on Building		
	Stud Spacing (mm)	Fastener Spacing (mm)		Stud Spacing (mm)	Fastener Spacing (mm)	
		E	F		E	F
N1	600	200	300	600	200	300
N2	600	200	200	600	200	300
N3	450	200	200	600	200	200

JOINT DETAILS

PVC H-Mould

Fix PVC H-Mould to frame at 200mm centres. Slide sheet into the side of the PVC H-Mould which has been fixed to the frame. Fix the sheet centre, top and bottom edges. Slide the next PVC H-Mould onto the other side of the sheet and fasten the mould and the adjacent sheet edge to the frame.

FIG 5: Joint Detail with PVC H-Mould

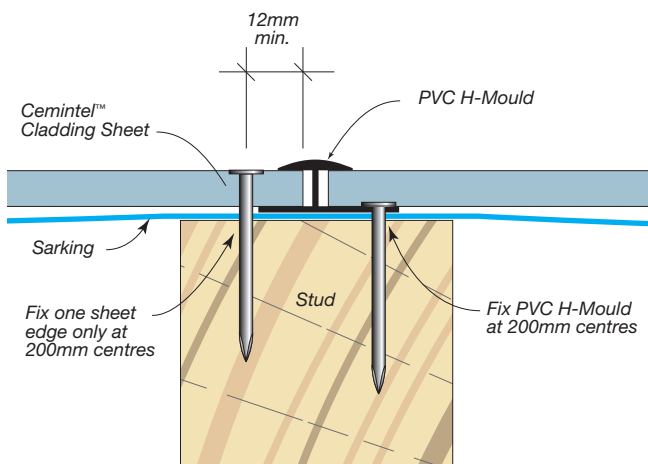

NOTE: Only one sheet edge at each joint is fastened directly to the frame. The other sheet edge is not fastened, but is held in place by the PVC H-Mould, to allow for movement.

PVC or Timber Cover Mould

Allow 3 to 4mm gap between sheets and fasten both sheet edges to the frame prior to fixing Cover Moulds. When a PVC Cover Mould is used, the hole for the fastener must be pre-drilled on the centreline. The Cover Mould is then fastened to the frame at 200mm centres.

FIG 6: Joint Detail with PVC or Timber Cover Mould

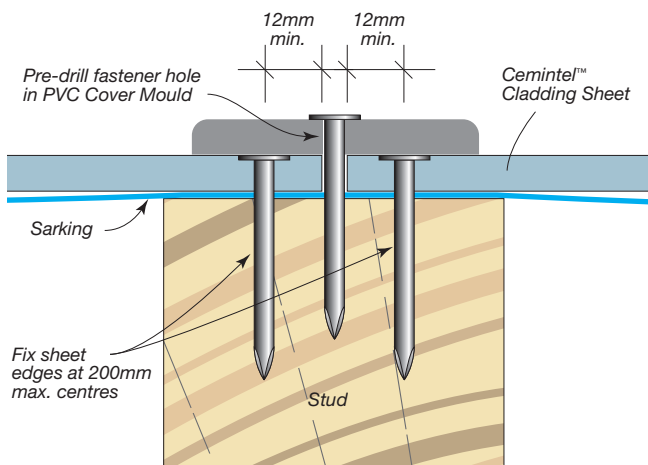

FIG 7: Internal Corner with PVC Internal Corner Mould

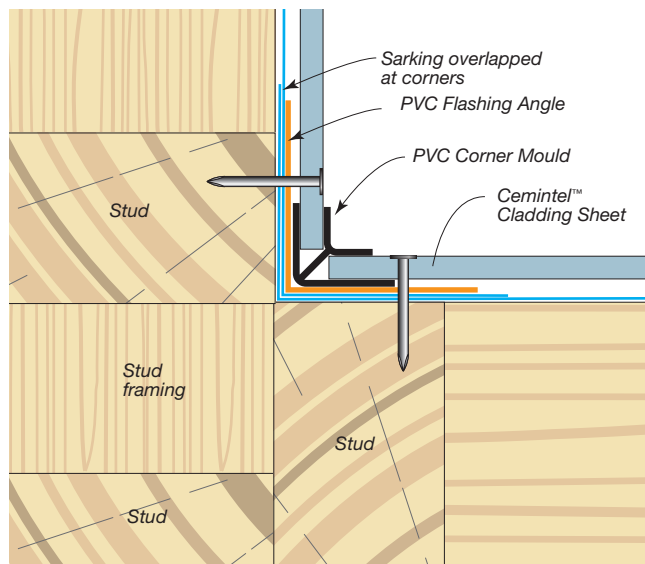

FIG 8: External Corner with PVC External Corner Mould

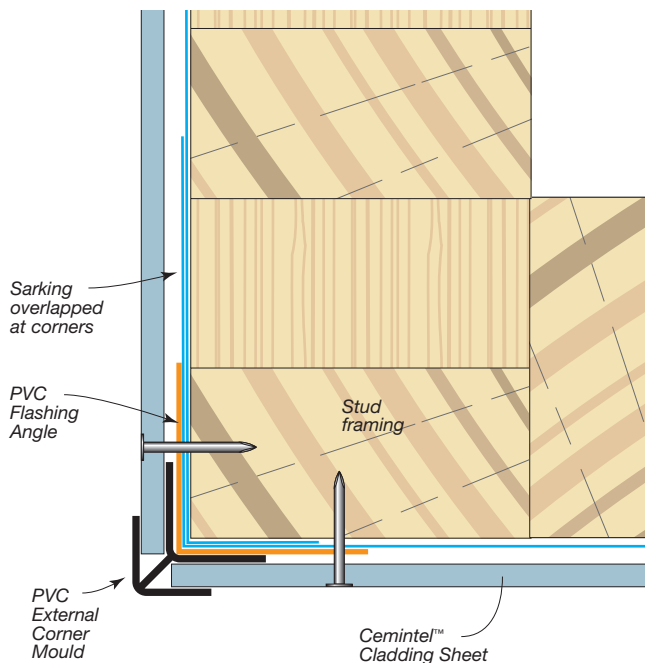

FIG 9: External Corner with PVC Angle Mould

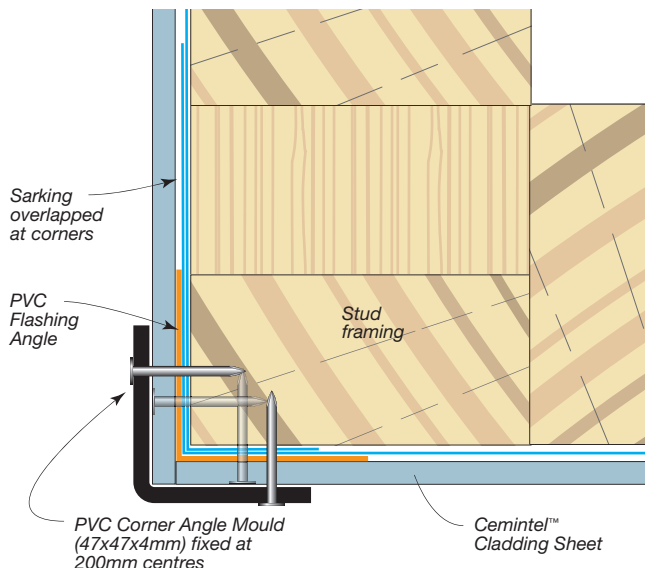
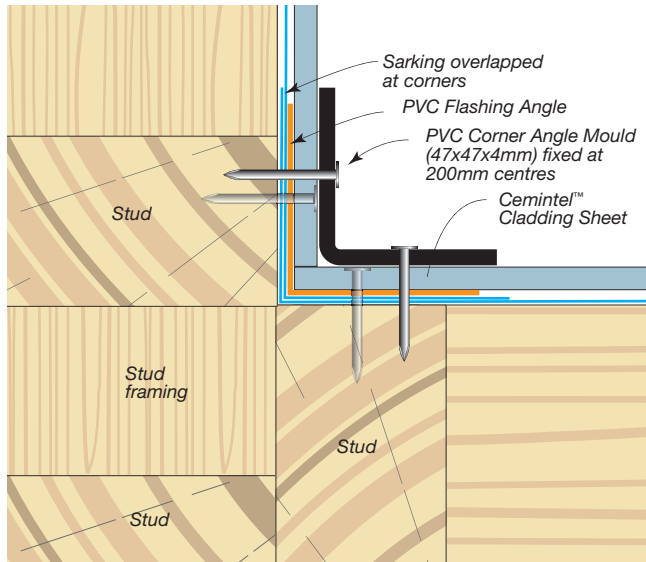
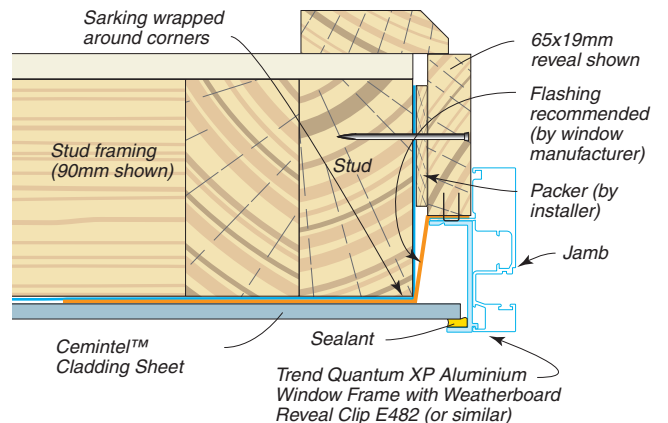
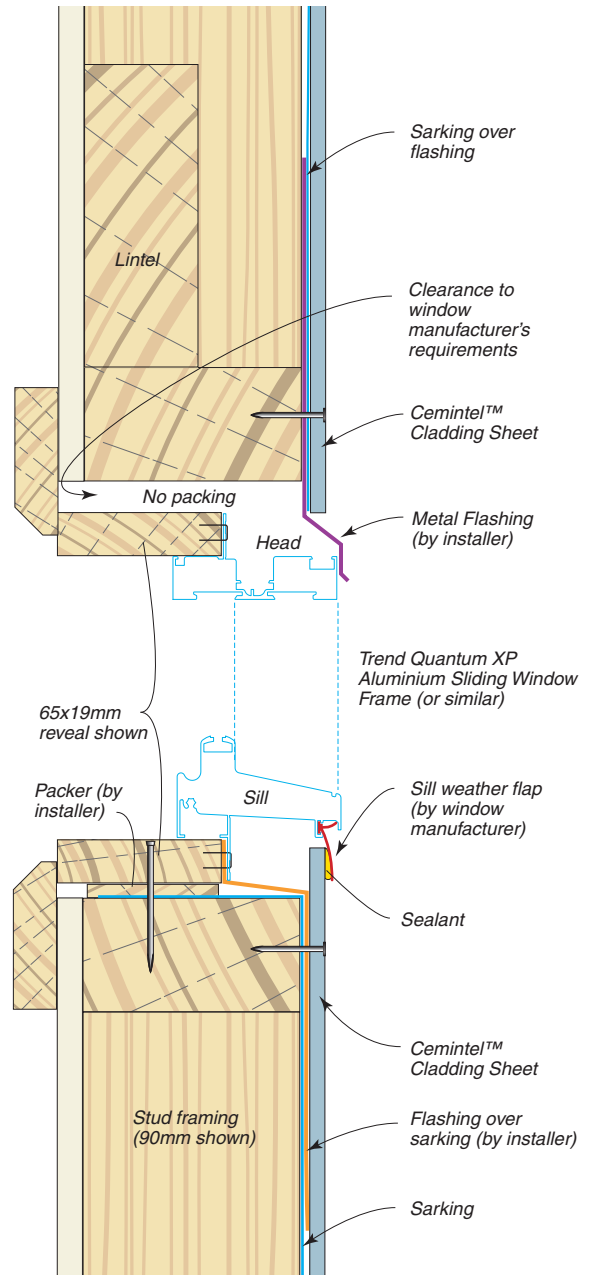

FIG 10: Internal Corner with PVC Angle Mould



WINDOW INSTALLATION

FIG 11: Window Detail – Trend Quantum XP Aluminium Sliding Window with Weatherboard Reveal Clip E482



INSTALLATION – CEILING AND EAVES

CEILING

Exterior ceilings may be lined with 6mm Cemintel™ Cladding Sheet. Nail or screw fix sheets to timber battens or direct to timber joists, with long edges spanning across the framing. Butt joints are to be formed on framing with minimum width 42mm to provide sufficient support for nailing. Otherwise, an additional stud or trimmer may be used to ensure fasteners have suitable edge distances.

Framing is to be spaced at maximum 600mm centres and to coincide with sheet lengths. Provide support to all sheet edges at openings and perimeters, and use framing to support fixtures such as lights and fans.

Table 3: Frame and Fastener Spacing – 6mm Cladding Sheet to Ceilings.

Wind Classification	Frame Spacing (mm)	Fastener Spacing (mm)	
		E	F
N1	600	200	300
N2	600	200	200
N3	450	200	200

EAVES

Eaves lined with Cemintel™ Eaves Lining Sheets are to be supported at the sheet long edges and with trimmers across sheets at specified centres. Sheets may be screw or nail fixed to framing, or edges may be supported in a fascia board rebate groove. Self embedding head screws are not to be used in 4.5mm Eaves Lining Sheet.

FIG 12: Typical Installation Detail for Eaves

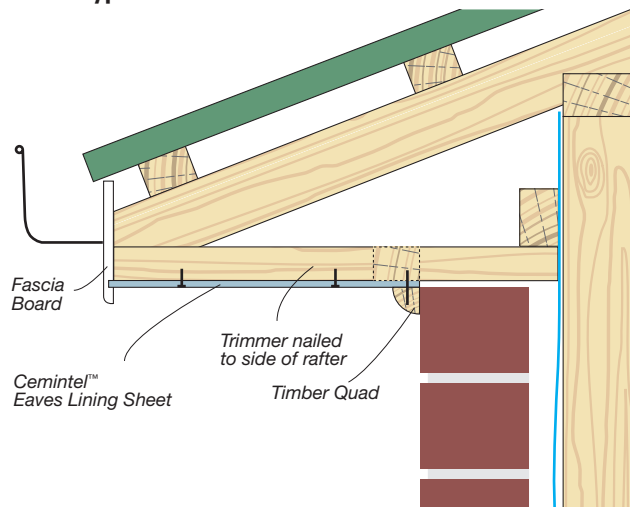

JOINT DETAILS

Butt Joint with PVC H-Mould – Eaves Sheet

Eaves Lining Sheet ends are joined using a PVC H-Mould. These joins do not need to be supported by a trimmer.

FIG 13: Butt Joint with PVC H-Mould Joint – Eaves

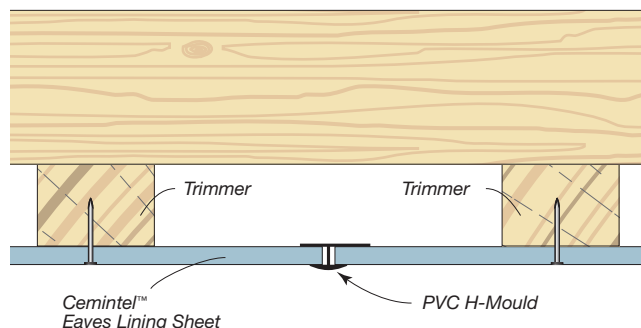

Butt Joint on Framing – Eaves Sheet

When no joining strip is used, sheets may be butted together with both sheet edges fastened to the frame.

Table 4: Frame and Fastener Spacing – 4.5 and 6mm Eaves Lining Sheet to Eaves

Eaves Width (mm)	Wind Classification	Trimmer Spacing (mm)		Fastener Spacing S (mm)	
		Within 1.2m of building corners	Elsewhere	Within 1.2m of building corners	Elsewhere
450 & 600	N1	600	900	200	300
	N2	600	800	200	300
	N3	500	700	200	300
750	N1	600	750	200	300
	N2	600	700	200	300
	N3	500	650	200	300

FIG 14: Butt Joint on Framing – Eaves or Ceiling

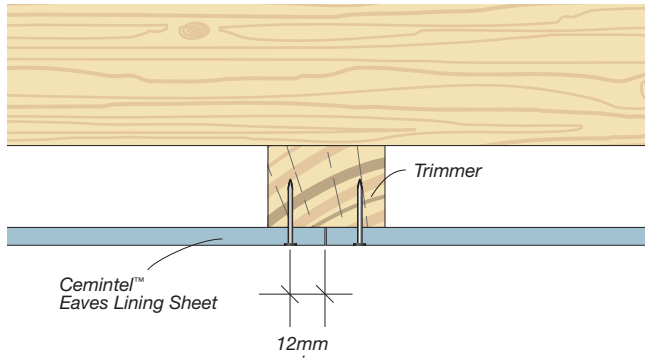

FIG 15: Butt Joint with PVC H-Mould – Ceiling or Eaves

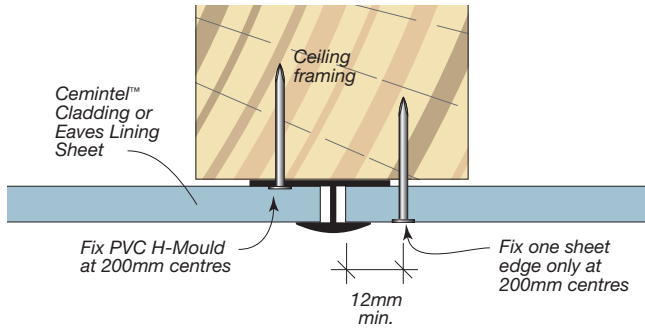

FIG 16: Edge Joint with PVC H-Mould – Ceiling

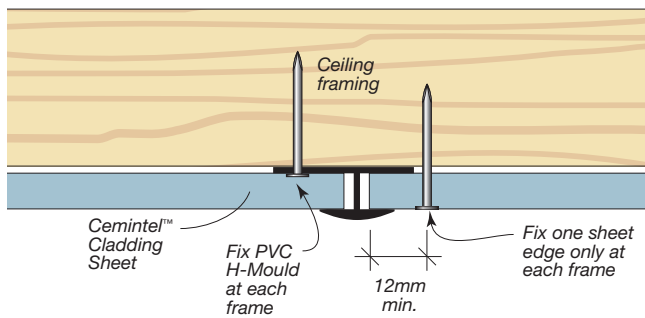
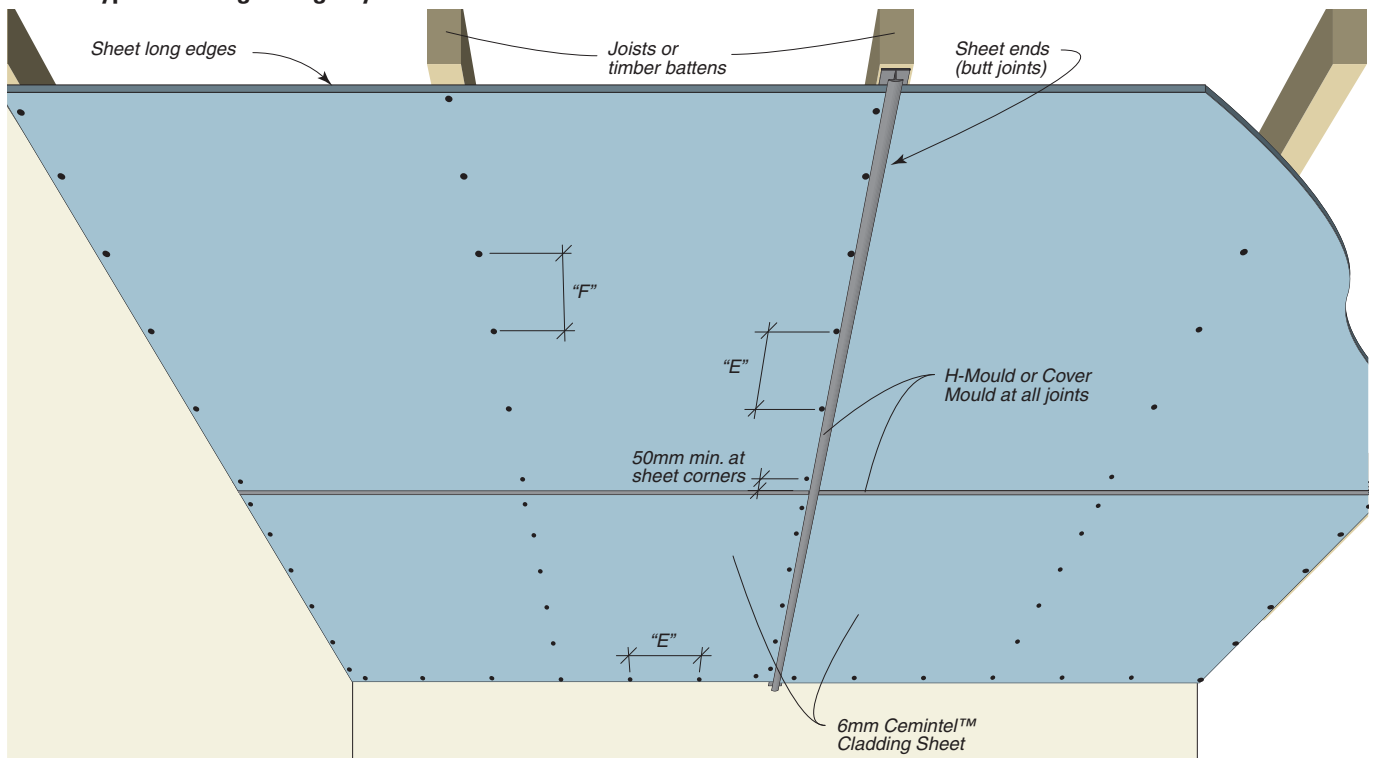

FIG 18: Typical Ceiling Fixing Layout



DECORATION

Cemintel™ sheets should be finished with a sealer and two coats of exterior grade acrylic paint. The surface must be clean and dry before application.

In all cases the paint manufacturer's instructions are to be followed.

FIG 17: Typical Eaves Fixing Layout

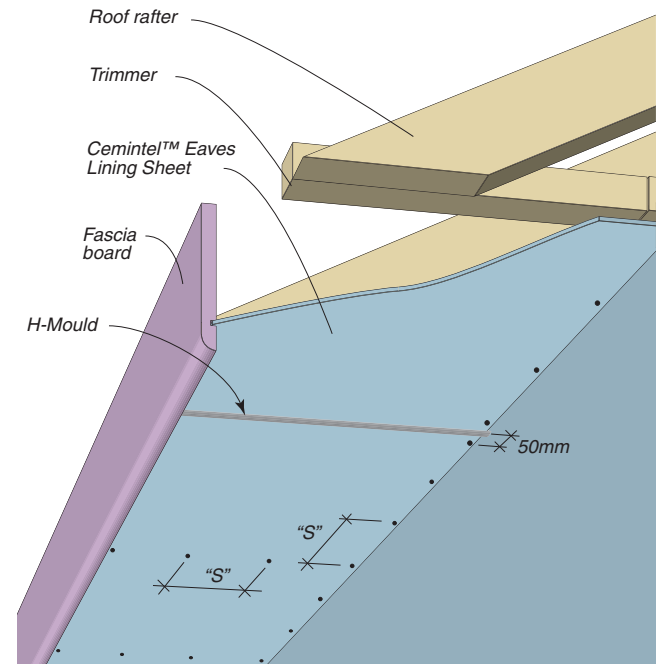

EXTERNAL CLADDING & EAVES LINING

FC:121



CEMINTEL® FIBRE CEMENT SYSTEMS, CSR BUILDING PRODUCTS LIMITED, A.B.N. 55 008 631 356

BMS9792.0711

cemintel™
fibre cement systems

www.cemintel.com.au

HEALTH & SAFETY

WARNING

Fibre Cement products contain crystalline silica. Repeated inhalation of fibre cement dust may cause lung scarring (silicosis) or cancer. Do not breathe the dust. When cutting sheets, use the methods recommended in this brochure to minimise dust generation. If power tools are used, wear an approved dust mask (respirator). These precautions are not necessary when stacking, unloading or handling fibre cement products.

For further information and for a Material Safety Data Sheet, phone 1800 807 668.

GUARANTEE

CSR Building Products Limited warrants its Cemintel™ Fibre Cement products to be free of defects in materials and manufacture. If a CSR product does not meet our standard, we will, at our option, replace or repair it, supply an equivalent product, or pay for doing one of these.

Other than as expressly set out in this warranty, and the warranties that cannot be excluded under The Australian Consumer Law (Schedule 2 of the Competition and Consumer Act 2010 (Cth)) (and any other law), CSR excludes all other warranties and guarantees with regard to Cemintel™ fibre cement products, including all implied warranties and guarantees.

The benefits given by this warranty are in addition to other rights and remedies of the consumer under law in relation to the goods or services to which the warranty relates.

CONTACT DETAILS

Cemintel™ Fibre Cement Systems

Sales Support

Tel: 13 17 44 Fax: 1800 646 364

CSR designLINK™ Technical Support Service

Tel: 1800 621 117 Fax: 1800 069 904

Email: designlink@csr.com.au

New South Wales and ACT

376 Victoria Street, Wetherill Park NSW 2164

Queensland

768 Boundary Road, Coopers Plains QLD 4108

Victoria

277 Whitehall Street, Yarraville VIC 3013

South Australia

Lot 100 Sharp Court, Mawson Lakes SA 5095

Western Australia

21 Sheffield Road, Welshpool WA 6106

Tasmania

PO Box 61, Glenorchy TAS 7010

Northern Territory

Cnr Stuart Hwy & Angliss St, Berrimah NT 0828