

SCARBOROUGH WEATHERBOARD



FC:966

EXTERNAL CLADDING SYSTEMS

OCTOBER 2008

Cemintel Scarborough[™] weatherboards are strong, durable fibre cement products for residential cladding. Designed to provide depth, they are resistant to fire and termites and are immune to permanent water damage. For use on new and existing buildings, Cemintel Scarborough[™] weatherboards are a low maintenance cladding system.

cemintel[™]
fibre cement systems



CSR

CONTENTS

Description	2
Features	2
Applications	2
Material Specifications	2
Design Considerations	3-4
Handling and Cutting	5
Preparation	6
Decoration & Maintenance	6
Components	7
Installation	8-15
Health & Safety	16
Guarantee	16
Contact Details	16

DESCRIPTION

Cemintel Scarborough™ Weatherboards are autoclaved, cellulose fibre reinforced, cement weatherboards designed for residential cladding. They will not rot or warp when correctly installed and maintained, and are resistant to fire and termite damage.

Cemintel Scarborough™ is a smooth faced weatherboard machined from 12mm thick baseboard. It is fixed in the traditional step pattern and has a nail fixing groove covered by a 25mm lap.

Cemintel Scarborough™ Weatherboards are supplied primed and, once installed, can be coated with an exterior grade paint system to provide a durable, low maintenance finish.

FEATURES

- Strong shadowline and simple fixing system.
- Immune to permanent water damage.
- Fire resistant.
- Termite resistant.
- Suited to gun and hand nailing.
- Provides a tough, durable cladding system.

APPLICATIONS

Cemintel Scarborough™ Weatherboards are suited to many residential external cladding applications including:

- Upper and lower storey additions
- Composite construction
- Over-cladding of existing walls
- Gable ends
- Infill panels
- Feature panels

Scarborough Weatherboards may be fixed to timber or steel framing. For buildings and wind loads in accordance with AS 4055, the products are suitable for wind zones N1 to N5/C3.

MATERIAL SPECIFICATIONS

Cemintel Weatherboard products conform to the requirements of AS/NZS2908.2 'Cellulose-cement products Part 2: Flat sheets.'

Cemintel Scarborough™ Weatherboards are factory coated with a pale yellow primer.

Table 1: Cemintel Scarborough™ Weatherboard

Thickness (mm)	Width (mm)	Length (m)	Unit mass (kg/m)	Area mass (kg/m ²)
12	175	4.2	2.74	15.7

FIRE RESISTANCE

When tested in accordance with AS1530.3, the Fire Hazard Indices for Cemintel Scarborough™ Weatherboard are as follows:

FIRE HAZARD INDICES

Product	EFHI	SMOGR _{Arc}	Group Number
Cemintel Scarborough™ Weatherboard	0/0/0/0	0	1

NOTES:

EFHI = Early Fire Hazard Indices (Ignitability/Spread of Flame/Heat Evolved/Smoke Developed).

SMOGR_{Arc} = Smoke Growth Rate Index.

DESIGN CONSIDERATIONS

This guide represents good practice, though it is not intended as an exhaustive statement of all relevant information. It remains the responsibility of the building designer to verify that Cemintel Scarborough™ Weatherboards are suitable for the particular requirements of any given project.

FRAMING

Cemintel Scarborough™ Weatherboards may be fixed to either timber or steel framing. Stud spacing shall be in accordance with Table 2 or 3.

Timber framing must comply with AS1684 'Residential Timber Framing Construction'. Timber with an equilibrium moisture content of less than 16% at the time of cladding application must be used. Unseasoned timber prone to shrinkage must not be used. Inspect the frame carefully for bowed, warped, or twisted studs; and for alignment of all framing members. Timbers that are not flush should be packed out or straightened.

Metal framing must comply with AS3623 'Domestic Metal Framing', and have a BMT of less than 1.6mm. Do not fix weatherboards to thicker cold rolled members or to hot rolled steel. Vertical timber or metal battens may be used over these members. Refer to framing manufacturer for appropriate products to suit coastal or other corrosive locations

WIND LOADING

Cemintel Scarborough™ Weatherboards are suitable for the specified wind classifications when installed to frames with maximum stud spacings as shown in Table 2 and 3.

WATER RESISTANCE

Wind forces can produce lower air pressures within buildings than on the outside, forcing water through gaps in the building envelope such as at penetrations and joints, even at low wind speeds. A sarking or wall wrap is highly recommended between stud frames and Cemintel Scarborough™ Weatherboards (CSR Bradford Enviroseal™ Wall Breather is recommended). Sarking must be designed and installed in accordance with AS/NZS 4200 Part 1: Materials, and Part 2: Installation, and should be sealed as for a vapour barrier.

The control of water ingress to a building is the responsibility of the designer. All flashings, damp proof courses and sealants must be installed in accordance with the relevant standards and building codes.

Condensation is a complex problem, and can occur under a variety of conditions, not just cold weather. Literature on this subject is available from CSIRO/BRANZ/ASHRAE and should be consulted when building in areas where condensation is likely to occur. In these cases, the appropriate use of a sarking as a vapour barrier or as thermal insulation, or both, can be effective in controlling condensation.

Table 2: Maximum Stud Spacing (mm) for Timber Framing

Cemintel™ Product	Fixing Location	Wind Category				
		N1	N2	N3/C1	N4/C2	N5/C3
Scarborough Weatherboard	General Zone	600	600	600	450	NA
	Corner Zone	600	600	450	300	NA

Notes: Corner Zones are areas within 1200mm of a building corner.
Framing is seasoned timber.

Table 3: Maximum Stud Spacing (mm) for Steel Framing

Cemintel™ Product	Fixing Location	Wind Category				
		N1	N2	N3/C1	N4/C2	N5/C3
Scarborough Weatherboard	General Zone	600	600	600	600	450
	Corner Zone	600	600	600	400	300

Notes: Corner Zones are areas within 1200mm of a building corner.
Steel framing is 0.55 to 1.6mm BMT.

THERMAL INSULATION

Insulation materials should be installed to enhance thermal insulation properties and occupant comfort. Insulation also improves the acoustic performance of the wall against outside noise.

Where occupant comfort is a consideration, the minimum recommendation is a reflective foil fixed to the outside of the frame, directly beneath the weatherboards. It is important that a vapour permeable foil be used, such as CSR Bradford Enviroseal™ Wall Breather.

Where greater thermal insulation properties are required, it is recommended that CSR Bradford wall batts be installed in the wall framing. Check with local building regulations for minimum insulation requirements.

The level of insulation provided in a wall is determined by its R-value. The higher the R-value the greater the insulation provided. See table below.

COLD CLIMATES

In cold climates where condensation in the wall cavity is possible, a vapour barrier is also recommended between any internal linings and the framing.

Cemintel Scarborough™ Weatherboards are not designed to be in contact with snow or ice build-up for extended periods, such as is experienced in alpine areas subject to snowdrifts. They are NOT to be used in freeze/thaw conditions.

When metal framing is used in extreme climates and clad with Cemintel Scarborough™ Weatherboards, additional precautions apply. Contact Cemintel™ for more details. Extreme climatic conditions include mountain and desert climates.

COASTAL AREAS

Cemintel Scarborough™ Weatherboards are suitable for use in coastal areas, which are defined as being within, 1km of a beach with breaking surf, or within 200m from a non-surf beach shoreline. Consideration must also be given to local weather and topographical features which can increase the distance that salt spray can travel.

To resist corrosion in these areas, salt laden air must be excluded from the wall cavity, for instance by lapping and sealing vapour barrier and flashing at corners, penetrations and joins. Salt laden air must also be excluded from entering the rest of the building envelope, such as the roof, etc.

All walls must be sufficiently exposed from above so that rain can perform natural wash down of the wall. Walls that are protected by soffits above must be washed down twice per year, to remove salt build-up. Ensure fasteners have manufacturers approval for use in the application.

Prior to the application of the external coating, wash down walls with clean fresh water to remove salt spray build-up from sheets and fixings. Sheets must be allowed to dry before coating

BRACING

Cemintel Scarborough™ Weatherboards are not designed to act as structural bracing.

Cemintel™ Weatherboard/Plank System	
<ul style="list-style-type: none"> • Cemintel™ Weatherboards or Planks. • Bradford Enviroseal™ Wall Breather. • Timber or Steel Studs (90mm) at 600mm maximum centres. • Insulation as per table below. • 1 layer x 10mm GYPROCK Plasterboard CD to the inside of framing. 	
Insulation Materials	Total Wall R-Value
(a) Nil	0.8
(b) Bradford ComfortSeal™ R1.5.	1.7
(c) Bradford Soundscreen™ R2.5	2.6

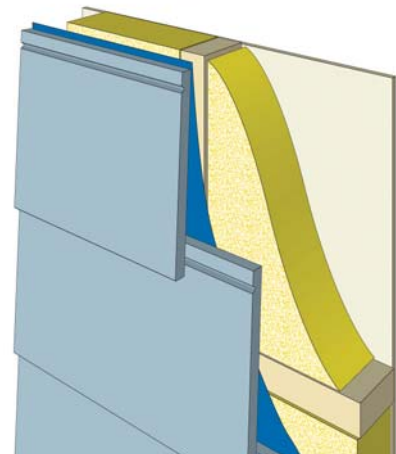

TERMITE PROTECTION

There is a wide variety of methods for managing termite entry to buildings, and selecting the appropriate method for any structure depends on specific risk factors and the form of construction. Measures for termite management have not been addressed in this guide.

Refer to your local pest management service, the BCA, AS3660, or your local building authorities for more information about the requirements for the design of a suitable termite management system.

HANDLING AND CUTTING

Cemintel Scarborough™ Weatherboards must be stacked flat, off the ground, and supported on a level platform. Care must be taken to avoid damage to edges, ends and surfaces.

Material must be kept dry, preferably by being stored inside a building. Where it is necessary to store material outside, it must be protected from the weather.

The following methods may be used for cutting Cemintel Scarborough™ Weatherboards.

Power Saw

For best results, use a circular saw with an appropriate blade. CSR recommends using the Hitachi Fibre Cement Power Saw Blade. This blade is specifically designed for use with fibre cement and produces a superior cut compared to conventional blades.

It is ideal for use with the Hitachi C7YA dustless circular saw and other 185mm circular saws fitted with vacuum extraction systems.



Hitachi C7YA Dustless Circular Saw with Dust Extraction System.



Hitachi Fibre Cement Power Saw Blade.

Compound Mitre Saw. Dust reducing saws used with fibre cement saw blades. Supplied by others.



Hitachi: C10FCE2
C12LSH

Makita: LSO714
LS1013
LS1212

Description	Order N°
Power Saw	10836
Power Saw Blade 185mm	10837
Dust Extractor	10833

PREPARATION

The number of weatherboards required for a wall can be calculated using the coverage table and the length of the wall.

Table 4 : Coverage Calculator

Scarborough Weatherboard	
Unit Width	175
Overlap	25
Number of Rows	Wall Height
1	175
2	325
3	475
4	625
5	775
6	925
7	1075
8	1225
9	1375
10	1525
15	2275
20	3025

Prior to fixing weatherboards, the following procedures should be completed:

- Fix Aluminium Extrusions or timber mouldings at internal and external corners, they should be fastened to the frame prior to fixing weatherboards.
- Wall openings, vertical joints, sills, heads and corners should be weatherproofed with flashing.
- Aluminium window trims should be fixed to aluminum window and door frames.
- Create a horizontal datum line and place temporary nails to support the first weatherboard.
- To ensure the first row of boards are at the correct angle, the PVC starter strip or packer should be fixed to the bottom plate. (See FIG 1)

DECORATION & MAINTENANCE

Cemintel Scarborough™ Weatherboards should be coated with two coats of exterior grade acrylic paint.

The surface must be clean and dry before application. In all cases, the paint manufacturer's instructions are to be followed.

The durability of the weatherboard system can be improved by periodic inspection and maintenance. Inspections should include examination of the paint, flashings and seals.

Paint finishes must be maintained in accordance with the manufacturer's recommendations. Any cracked or damaged flashings or seals that would allow water ingress must be repaired immediately. Any damaged weatherboards must be replaced.

The durability of the system can also be increased by painting all exposed sealants to the sealant manufacturer's recommendations.

COMPONENTS

SCARBOROUGH WEATHERBOARDS

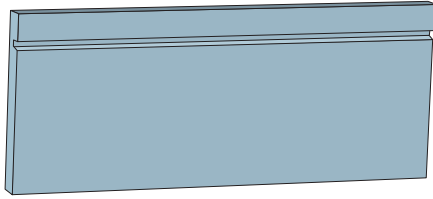

Code N°	Thickness (mm)	Width (mm)	Length (m)	Weight (kg)
89474	12	175	4.2	11.5

FASTENERS

Fibre Cement Nails:



- Hot dip galvanised 2.8 x 40mm for softwood and hardwood frames. Not suitable for use in coastal areas.

Order N°	Qty
77258	2kg

- Hot-dip galvanised 2.8mm x 50mm for fixing over existing cladding up to 10mm thick. Not suitable for use in coastal areas.

Order N°	Qty
77259	2kg

- Stainless Steel 2.8 x 40mm for softwood and hardwood frames. For use in high corrosion zones including coastal areas. Refer to 'Design Considerations'.
- Bullet head galvanised nail 3.15 x 60mm gal. (Supplied by others)

Gun Nailing:

Used for concealed fixing to timber frames. Ensure nails meet durability requirements. Minimum nail requirements: length 40mm and diameter 2.5mm.

Fibre Cement Screws for steel framing:

- Buildex Fibre ZIPS™, 9-18 x 30mm Class 3 finish. For steel framing of 0.55 to 1.6mm.

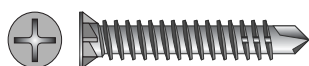

Order N°	Qty
13165	1000

NOTE: In high corrosion zones, such as the coastal marine environment, Class 4 screws must be used.

BUTT JOINTS

Off-Stud Joiner (Soaker)

- Used to join Scarborough Weatherboards off-stud, in conjunction with Sikaflex 11FC Adhesive.

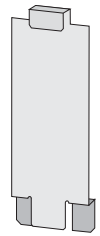

Order N°	Item
89857	Soaker
39378	Sikaflex 11FC 350 ml tube (Grey)

STARTER STRIP

- PVC starter strip for aligning the first Scarborough Weatherboard.

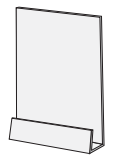

Order N°	Length
89098	3000mm

EXTERNAL CORNER EXTRUSION

- Aluminium accessory with chromate finish.

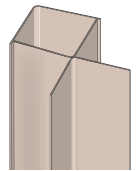

Order N°	Length
89096	3000mm

INTERNAL CORNER EXTRUSION

- Aluminium accessory with chromate finish.

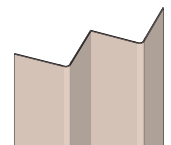

Order N°	Length
89095	3000mm

WINDOW TRIM

- Aluminium accessory with chromate finish.

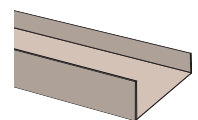

Order N°	Length
89097	3700mm

FLEXIBLE SEALANT

- Sikaflex PRO™ 2HP polyurethane sealant for filling gaps around windows, doors and other penetrations.

Order N°	Item
11378	310ml Tube (Grey)
39488	310ml Tube (Black)

INSTALLATION

Scarborough Weatherboards are installed using a PVC starter strip or packing strip. Starter strip is installed horizontally and fixed to frame at 600mm maximum centres. Boards should be fixed to steel or timber framing using the appropriate fasteners.

Begin fixing first weatherboard at an external corner, ensuring the board is flush with the corner moulding or extrusion. Position the board over the starter strip and fix the top to each stud in the nailing groove. Alternatively, rest the board on datum line nails, and fasten the bottom edge to each stud, through a packing strip. Fasten the top to each stud, in the nailing groove. Refer to FIG 1, 2, 3 and 4.

Fix the first row of weatherboards around the perimeter of the building, cutting to length as appropriate for on-stud or off-stud jointing. Once the first row is complete remove the guide nails.

Begin the second row with an off-cut to ensure that the joints are staggered along the wall. Lap boards to a minimum of 25mm. Fix the top of each board in the nailing groove to every stud. Check rows for level.

Fasteners should be located in the nailing groove 20mm minimum from ends. Pre-drill holes for fixings at board ends to avoid corner damage while installing.

Continue fixing successive weatherboards working up the wall.

JOINTS

Plan vertical layout so that, where possible, a full width weatherboard occurs above and/or below openings. If a weatherboard has been reduced in width, provide a joint to at least one side of the opening. Refer to FIG 7.

When a window or door opening exceeds 1800mm width, it is necessary to have a joint above and below the opening for both full and reduced width weatherboards, to allow for movement. Joints at ends of weatherboards should be located randomly throughout the wall to reduce visual impact.

Weatherboard ends should be cut square and sanded smooth in preparation for butt joints. Joints formed on a stud may require additional framing to allow sufficient edge distances for fixings. Refer FIG 8.

Cemintel Scarborough™ Weatherboards may also be installed with joints located between studs, utilizing the metal soaker Refer FIG 9.

CORNER DETAIL

Internal and external corners can be finished by butting boards to timber mouldings. Aluminium extrusions for internals and externals are also available.

Aluminium corner extrusions or timber mouldings must be installed prior to the fixing of boards. Board ends must be straight and square, and are to be butted up firmly to the moulding. Fasteners should be 20mm minimum from board ends and holes must be pre-drilled where closer than 50mm from board ends. Refer to FIGS 10-15.

For Aluminium corner extrusions, fix both legs of the inner part at 400mm centres to corner studs before installing weatherboards.

Angle flashing must be used at all internal and external corners where sarking is not used or where additional weatherproofing is required.

WINDOWS

Scarborough Weatherboards (lap projection of 27mm) are generally too thick to fit into the external flange of most [residential aluminum window](#) suites.

An aluminium window trim accessory is available to be fitted to the window perimeter prior to fitting the weatherboards. The trim covers the ends of boards that butt to the window frame providing a neat finish. The window trim should be screwed to the window reveal. Refer FIGS 16 and 17.

Alternatively, the window can be “trimmed” with a timber moulding, such as, primed LOSP. The timber moulding is fitted to the window perimeter first, and Scarborough weatherboards butted to the moulding. This provides a flush detail without unsightly spider holes. Double stud at the opening are required. Refer FIGS 18 and 19.

These trim options are also suited to other openings for hinged, sliding and garage doors.

All openings should be suitably flashed prior to the fixing of Scarborough Weatherboards.

NAIL FIXING

Scarborough Weatherboards are intended to have a concealed fixing system. This is achieved via fixing the board only in the top face groove. Refer FIG 1 and 2.

Boards may be fixed via either hand nailing or nail gun. For gun nailing use nails of 40mm minimum length and 2.5mm minimum diameter. Ensure nails meet the durability requirements.

Where framing irregularities cause a gap between boards at the lap, additional face nailing with a bullet head nail may be a useful option for affected areas. Refer FIG 6.

FIG 1: Base Detail with PVC Starter Strip

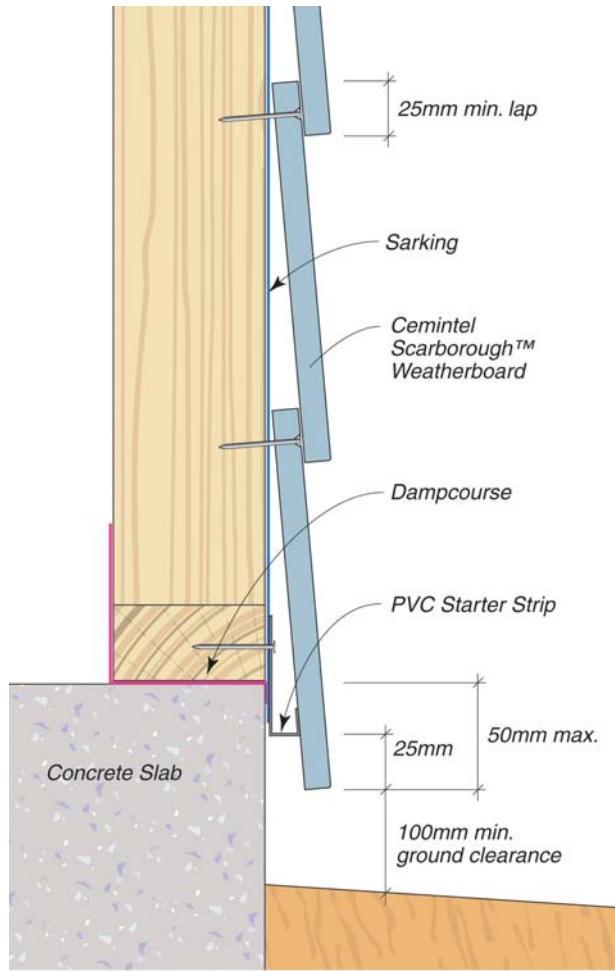

NOTE: Drill 2mm dia. drain holes in Starter Strip at 1 metre centres

FIG 2: Screw Fixing with Timber Packing Strip

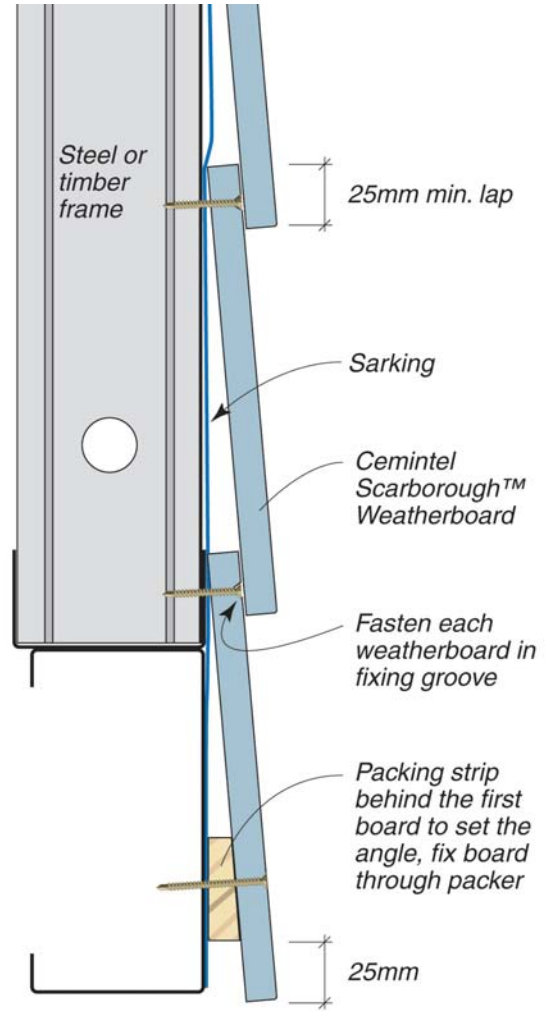

FIG 3: Nail Driving Detail

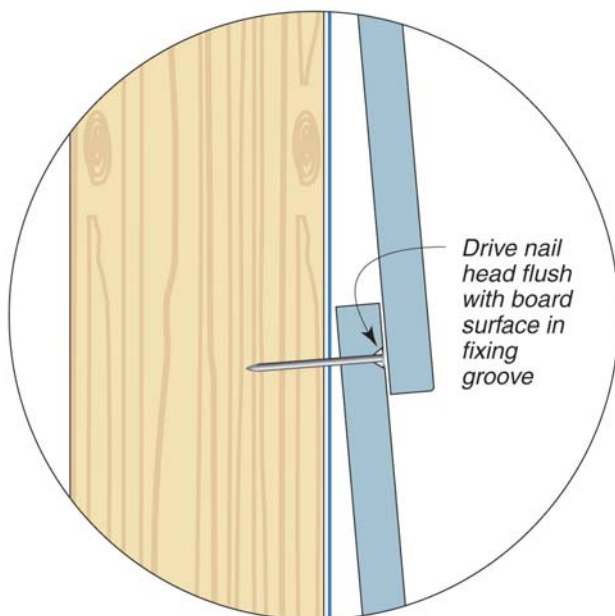

FIG 4: Installation Start-up Detail

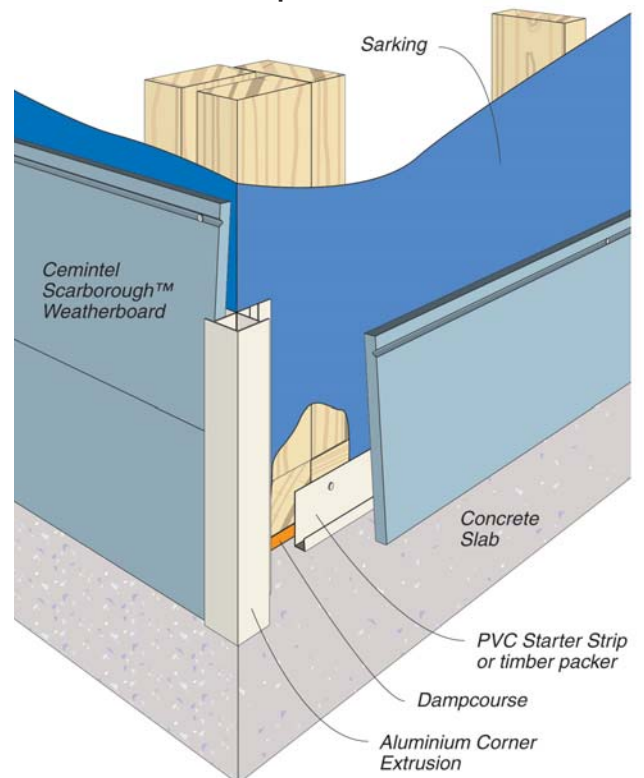

FIG 5: Weatherboard Set-out

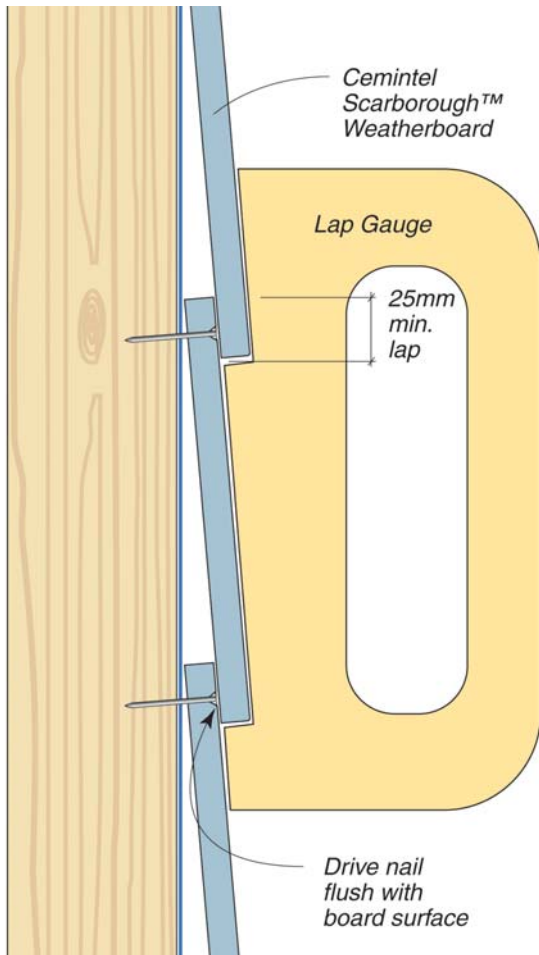

FIG 6: Optional Lap Fixing

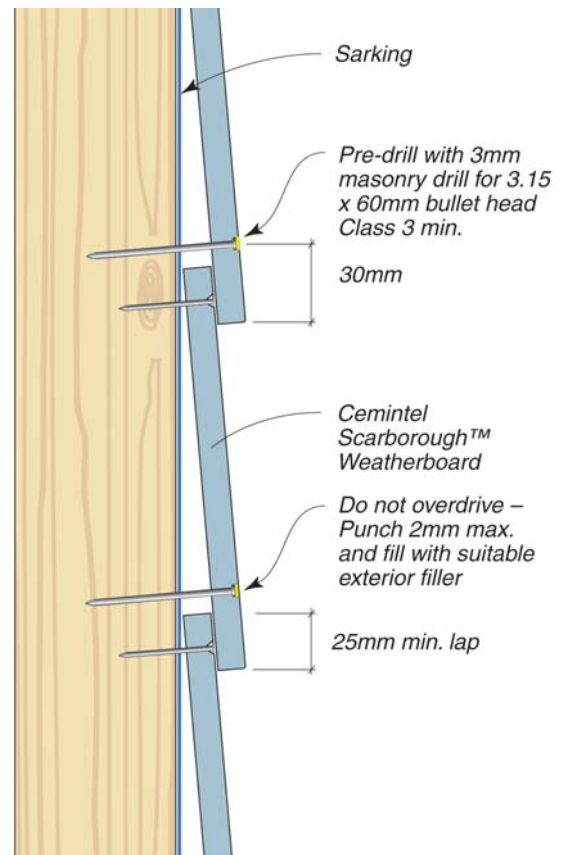

FIG 7: Window Openings

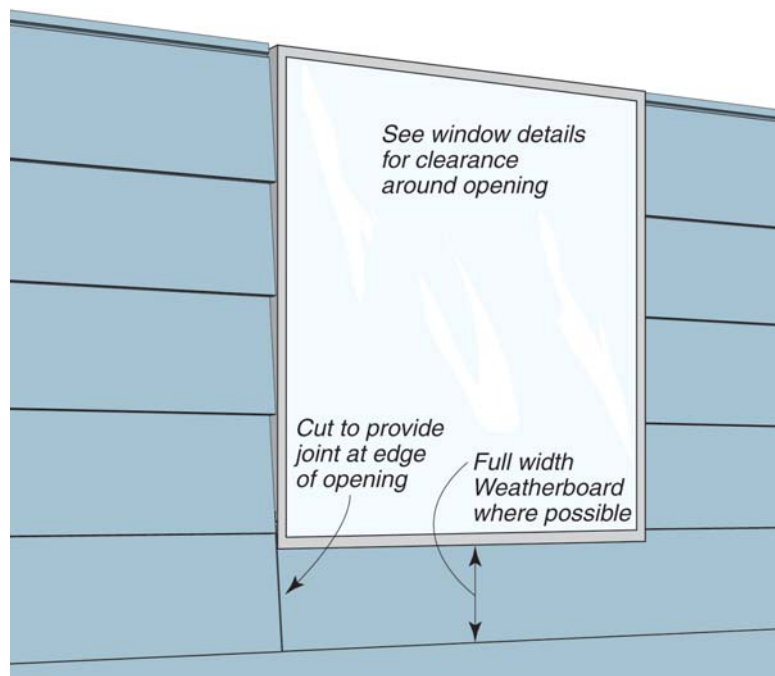

FIG 8: On-stud Jointing

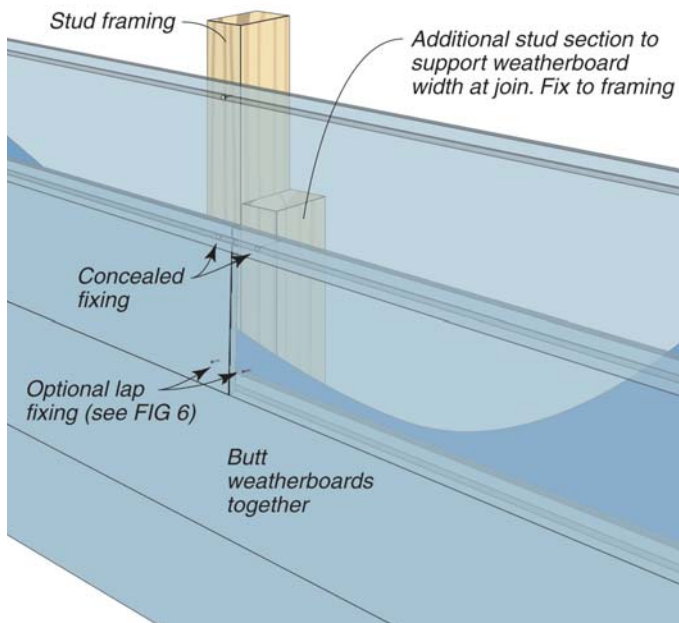

FIG 9: Off-stud Jointing

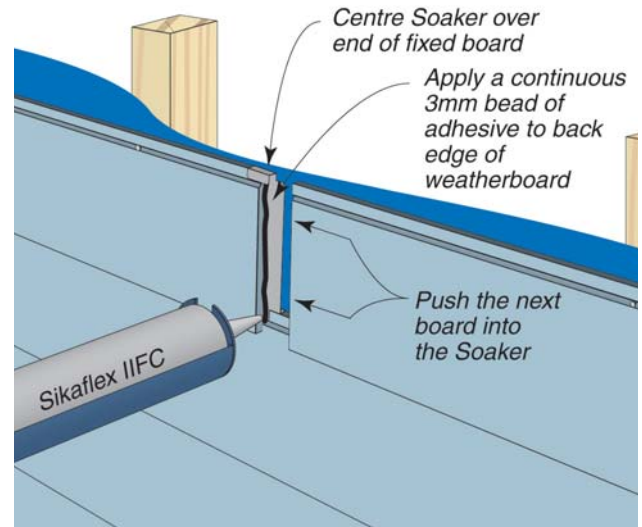

FIG 10: External Corner with Timber Moulding

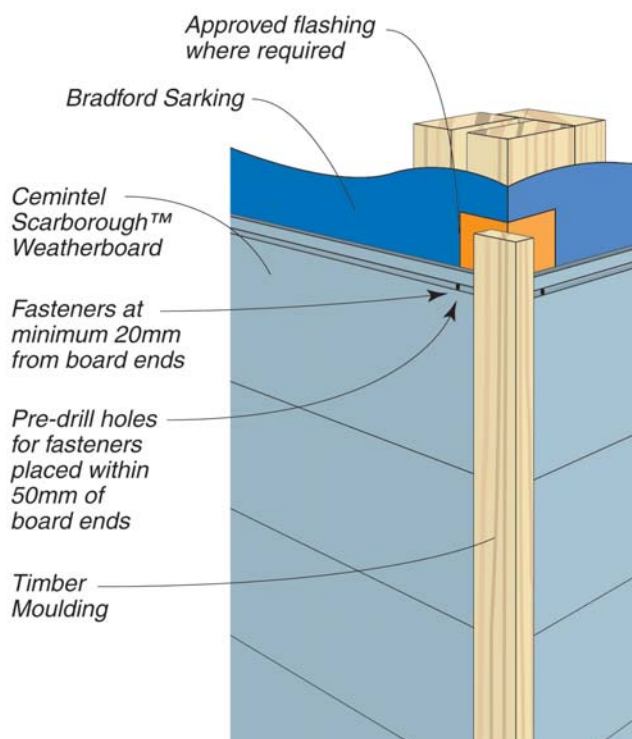

FIG 11: Internal Corner with Timber Moulding

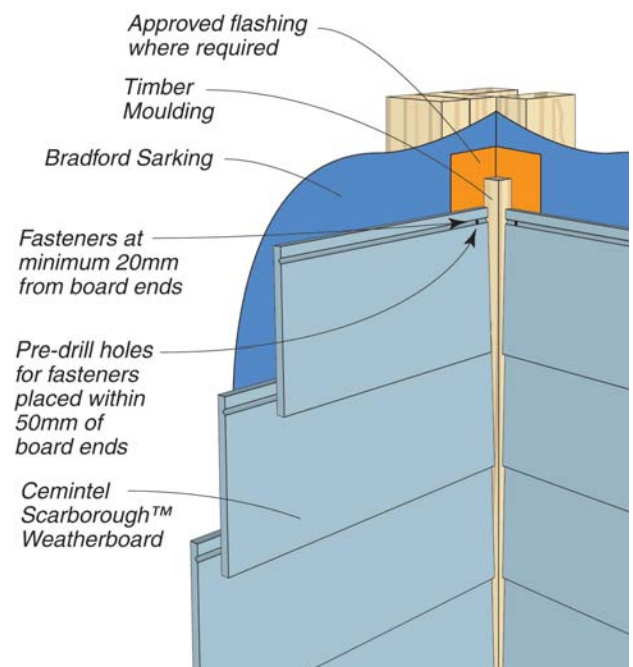

FIG 12: External Corner with Aluminium Corner Extrusion

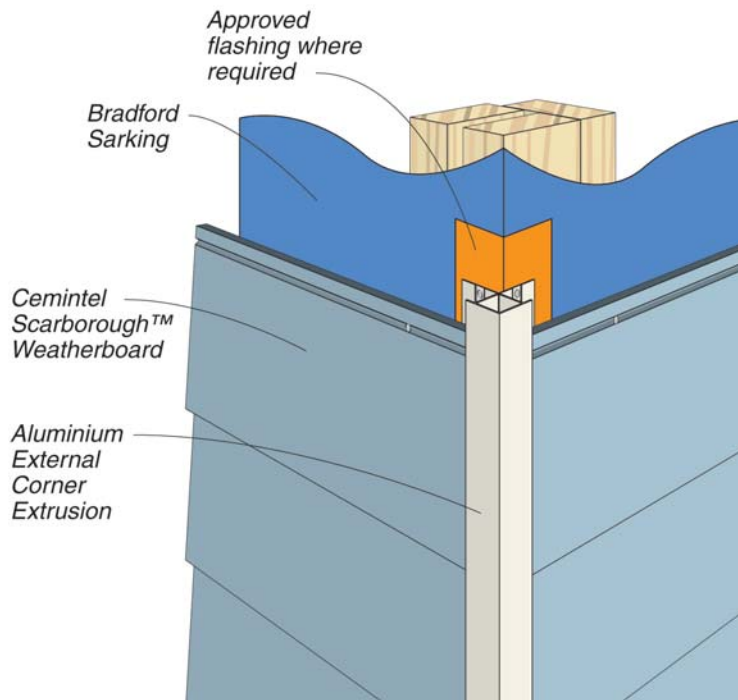

FIG 13: External Corner with Aluminium Corner Extrusion

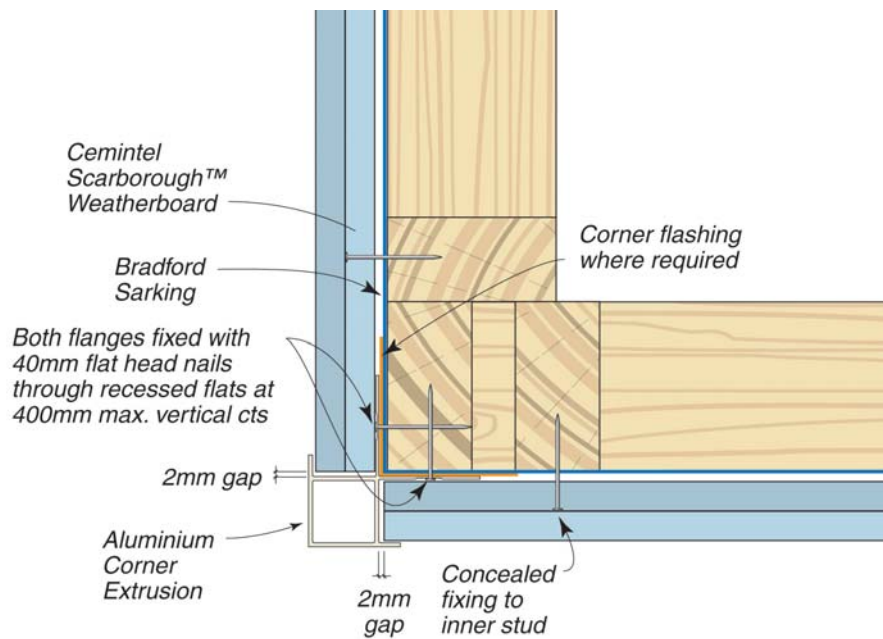

FIG 14: Internal Corner with Aluminium Corner Extrusion

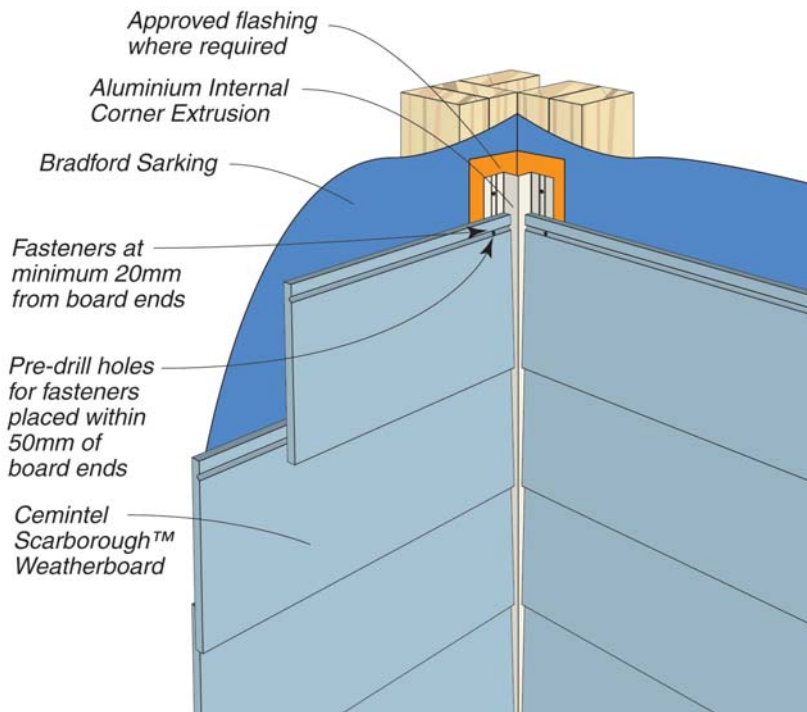

FIG 15: Internal Corner with Aluminium Corner Extrusion

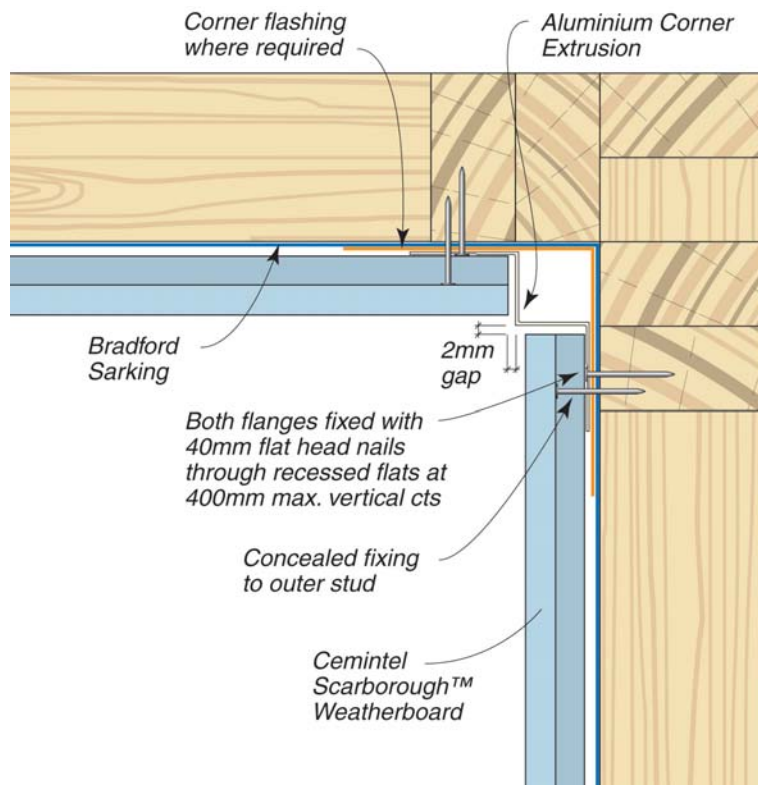

FIG 16: Aluminium Window Trim Head/Sill Detail

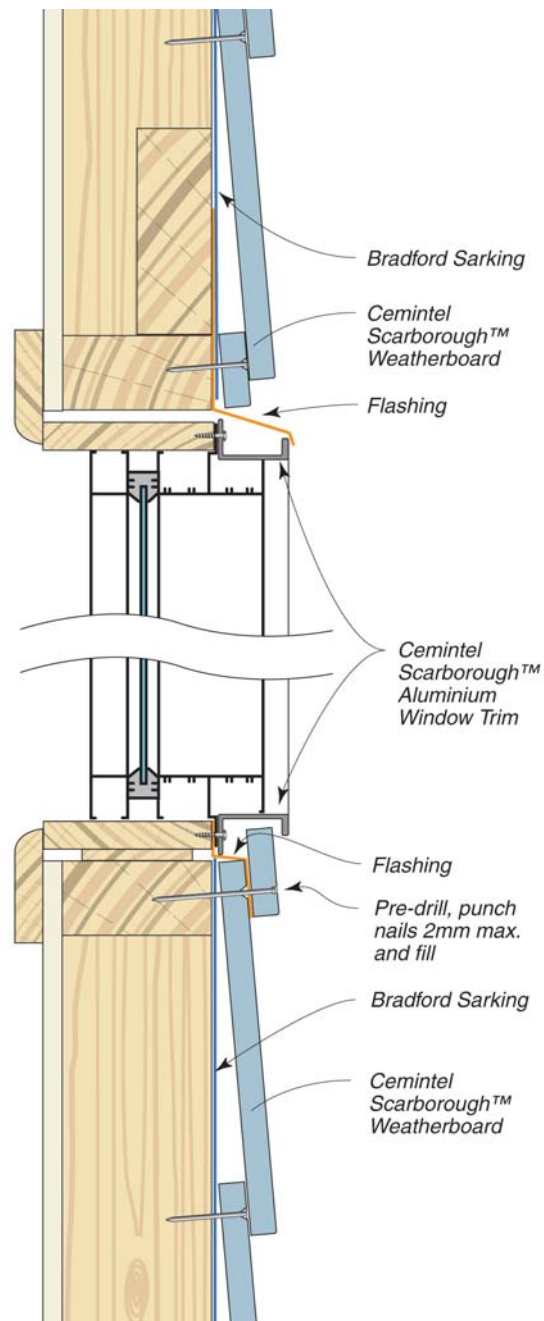

FIG 17: Aluminium Window Trim Jamb Detail

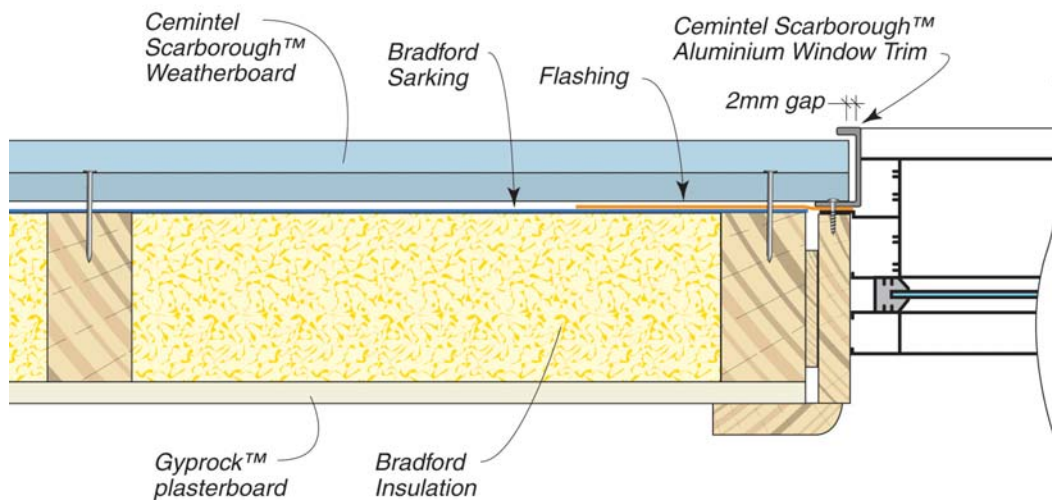

FIG 18: Timber Window Trim Head/Sill Detail

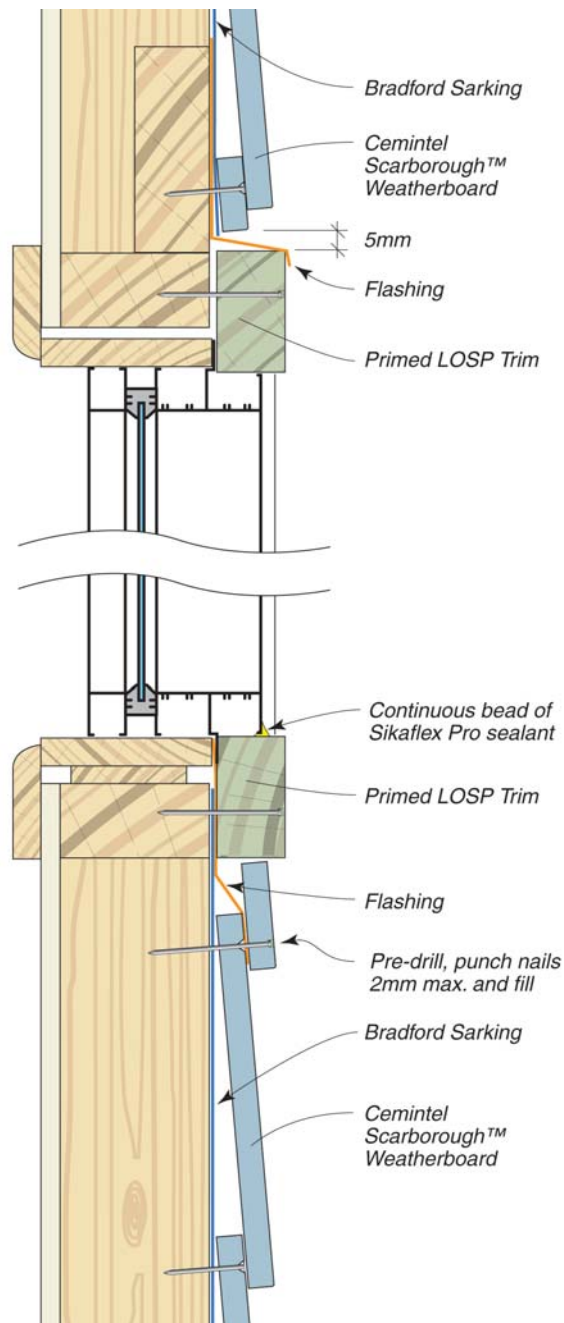
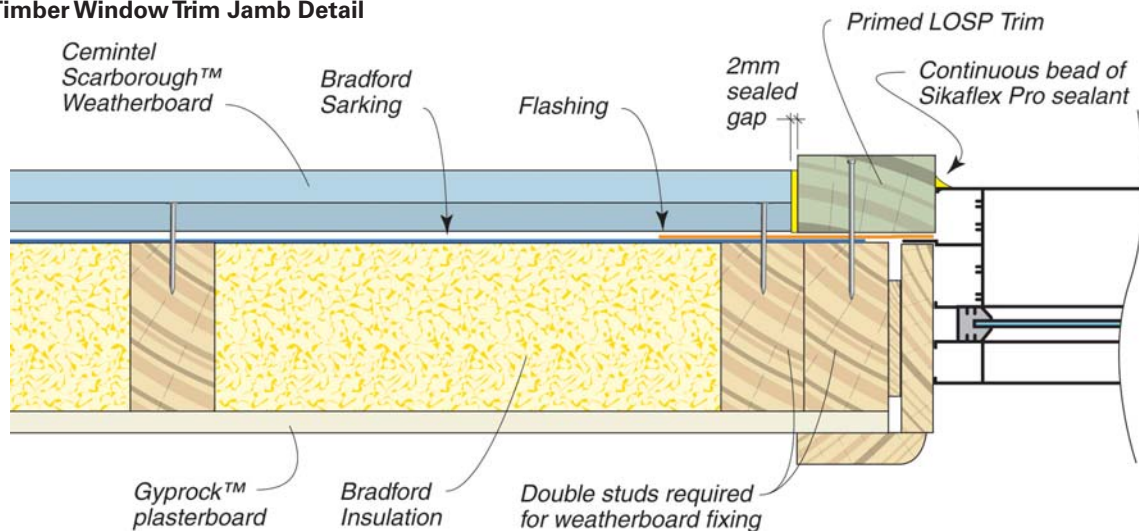

FIG 19: Timber Window Trim Jamb Detail



SCARBOROUGH WEATHERBOARD



FC:966

EXTERNAL CLADDING SYSTEMS

OCTOBER 2008

CEMINTEL[®] FIBRE CEMENT SYSTEMS CSR BUILDING PRODUCTS LIMITED, A.B.N. 55 008 631 356

cemintel[™]
fibre cement systems

www.cemintel.com.au

HEALTH & SAFETY

WARNING

Fibre Cement products contain crystalline silica. Repeated inhalation of fibre cement dust may cause lung scarring (silicosis) or cancer. Do not breathe the dust. When cutting sheets, use the methods recommended in this brochure to minimise dust generation. If power tools are used, wear an approved dust mask (respirator). These precautions are not necessary when stacking, unloading or handling fibre cement products.

For further information and for a Material Safety Data Sheet, phone 1800 678 068.

GUARANTEE

CSR Building Products Limited warrants its Cemintel[™] Fibre Cement products to be free of defects in materials and manufacture. If a CSR product does not meet our standard, we will, at our option, replace or repair it, supply an equivalent product, or pay for doing one of these.

This warranty excludes all other warranties and liability for damage or loss in connection with defects in CSR's product, other than those compulsorily imposed by legislation, notably the Trade Practices Act.

CONTACT DETAILS

Cemintel[™] Fibre Cement Systems Sales Support

Tel: 13 17 44 Fax: 1800 646 364

CSR designLINK[®] Technical Support Service

Tel: 1800 621 117

New South Wales and ACT

376 Victoria Street, Wetherill Park NSW 2164

Queensland

768 Boundary Road, Coopers Plains QLD 4108

Victoria

277 Whitehall Street, Yarraville VIC 3013

South Australia

Lot 100 Sharp Court, Mawson Lakes SA 5095

Western Australia

21 Sheffield Road, Welshpool WA 6106

Tasmania

PO Box 61, Glenorchy TAS 7010

Northern Territory

Cnr Stuart Hwy & Angliss St, Berrimah NT 0828