



CEILING SYSTEMS –
SOFFITLINE® & CEMINSEAL® WALLBOARD
External & Internal Ceiling Systems



TABLE OF CONTENTS

01 INTRODUCTION	2	07 INSTALLATION, CONSTRUCTION	
Introduction	2	DRAWINGS + DETAILS	25
02 PRODUCT OVERVIEW	3	Sheet Installation	26
Sheet Information	4	Internal Ceiling Systems	27
03 SYSTEM OVERVIEW	5	External Ceiling Systems	27
Applications	6	Installation Details For Soffitline Ceiling	
Advantages	6	Systems – External Ceiling With	
Ceiling System Selection	7	Flush-Set Joints	28
04 DESIGN + AESTHETIC CONSIDERATIONS	8	Installation Details For External	
System Selection/Wind Loading	9	And Internal Ceiling Systems –	
Ceiling Framing	9	With Expressed Joints	31
Control Joints	9	Installation Details For Internal Ceiling	
Penetrations	10	Systems – With Expressed Joints	33
Insulation	10	Installation Details For External Ceiling	
Corrosivity Categories/Coastal Areas	10	Systems – With Expressed Joints	35
Indoor Pool Design Considerations	10	Installation Details For Internal Ceiling	
Building Renovations	11	Systems – With Flush-Set Joints	36
Painting	11	08 JOINTING	40
Wash Down Process	11	Internal Systems	41
Inspection, Repair and Maintenance	12	External Systems	42
05 COMPONENTS + ACCESSORIES	13	09 SAFETY, HANDLING, GENERAL CARE + WARRANTY	43
06 SYSTEM ENGINEERING	16	Health, Safety and PPE	44
Design, Detailing and Performance		Safety, Handling, and Maintenance	44
Responsibilities	17	Warranty	44
Design Information	18		

Introduction

Cemintel® Ceiling Systems are designed for external and internal applications, and are suitable for use with steel and timber framing. Systems are available with expressed joints or with flush-set joints. They are easy to install and require minimal maintenance.

For external applications, the Cemintel Soffitline® (“Soffitline”) ceiling system is recommended where a flush joint appearance is required. The system comprises of Soffitline fixed to top hats or furring channels on a variety of framing types. Soffitline is a fibre cement sheet that is formulated with a unique penetrating water block technology for added weather resistance and durability. It is used with a purpose designed acrylic jointing system that has increased joint strength and reduces the need for sanding. The CeminSeal® Wallboard SE with square edge panels can be used for an expressed joint finish ceiling system.

For internal ceilings, CeminSeal® Wallboard are used. It also includes water block technology and has a smooth flat surface for easy finishing. It is available in recessed edge (RE) for a flush jointed finish, or square edge (SE) for an expressed joint finish.

This Design and Installation Guide recommends good building practice methodology and has been prepared as a general guide on design considerations, system engineering information and installation procedures for **common ceiling applications**. It assumes that the user has an intermediate knowledge level of building design and construction. In no way does it replace the services of the building professionals required to design projects, nor is it an exhaustive guide of all possible scenarios.

It is the responsibility of the architect, designer and various engineering parties to ensure that the details in this Design and Installation Guide are appropriate for the intended application.



022

PRODUCT OVERVIEW

Sheet Information

LININGS

Soffitline is an autoclaved, cellulose reinforced fibre cement sheet which is formulated with a unique penetrating water block technology for added weather resistance and durability. Sheets are tinted lilac and long edges are recessed (RE).

Soffitline is 6mm in thickness.

		Soffitline Sheet Sizes					
Thickness (mm)	Width (mm)	Length (mm)					
		1800	2400	2700	3000	3600	4200
6mm RE	1200					•	

RE: Recessed Edge

CeminSeal Wallboard is an autoclaved, cellulose reinforced fibre cement sheet for use in ceilings and interior wet areas. It is available with long edges recessed (RE) or a square edge finish (SE). CeminSeal Wallboard is available in 6mm and 9mm thickness.

		CeminSeal Wallboard Sheet Sizes					
Thickness (mm)	Width (mm)	Length (mm)					
		1800	2400	2700	3000	3600	4200
6mm RE	900				•		
	1200	•	•	•	•	•	•
	1350		•		•	•	•
6mm SE	1200		•	•	•	•	
9mm RE	1200		•	•	•		
9mm SE	1200			•	•		

RE: Recessed Edge SE: Square Edge

Product Specifications

Cemintel fibre cement products conform to the requirements of AS/NZS 2908.2, 'Cellulose cement products Part 2: flat sheets' for Type B Category 3.

Wallboard – Mass (6mm thickness nominal)	9.4kg/m ²
Wallboard – Mass (9mm thickness nominal)	14.0kg/m ²
Soffitline – Mass (6mm thickness nominal)	9.4kg/m ²
Length (manufacturing tolerance)	+0 to -4mm
Width (manufacturing tolerance)	+0 to -3mm
Thickness (manufacturing tolerance)	+0.5 to -0mm

Fire Hazard Properties

The National Construction Code (NCC) limits the materials used in Class 2 to 9 buildings by controlling the Fire Hazard Properties of linings. These properties are assessed using AS ISO 9705 room burn test, AS/NZS 3837 cone calorimeter test, AS1530.2 and AS1530.3.

In accordance with the NCC C2D10, Cemintel fibre cement sheet products may be used wherever a non-combustible material is required.

The fire hazard properties for Soffitline and CeminSeal Wallboard sheets are as follows:

Group Number	1
SMOGR _{A,RC}	≤ 0.2 (in m ² /s ² x 1000)
Ignitability	0
Spread of Flame	0
Heat Evolved	0
Smoke Developed	1

Note: SMOGR_{A,RC} = Smoke Growth Rate Index

03

SYSTEM OVERVIEW

03

SYSTEM OVERVIEW



Applications

Soffitline has been developed for use in flush jointed external ceilings such as those found in:

- Retail and Industrial Awnings;
- Verandahs, Balconies (Residential and High-Rise) and Car Parks; and
- Car Park Canopies.

CeminSeal Wallboard (SE) lining is suitable for external and internal use for expressed joint ceilings and may also be used in high humidity internal areas such as indoor pools. For more information, refer to 'INDOOR POOL DESIGN CONSIDERATIONS' on page 11.

CeminSeal Wallboard (RE) lining is suitable for use in flush jointed internal ceilings in applications such as:

- Sports Halls;
- Secure Areas; and
- Industrial Storage Areas.

Recessed Edge CeminSeal Wallboard is suitable for most internal applications. It remains the responsibility of the building designer to verify a particular Cemintel Ceiling System and ceiling support framing is suitable for the requirements of a project.

Advantages

- Expressed joint or flush joint appearance.
- High strength jointing system with reduced sanding.
- Easy installation.
- Internal and external applications.
- Smooth surface ready for finishing.
- Accepts a wide range of paint finishes.

SYSTEM OVERVIEW



Ceiling System Selection

TABLE 4.01 Cemintel Ceiling Systems

Framing & Jointing Type	Sheet Module Layout	Features & Applications
SOFFITLINE CEILING SYSTEM – EXTERNAL CEILING WITH FLUSH-SET JOINTS		
		<p>Features</p> <ul style="list-style-type: none"> • External applications • 6mm Soffitline recessed edge lining • Flush-set joints • Top hats fixed to timber or steel joists, trusses or suspension system • Sheet module size up to 3.6m x 3.6m • Framing control joint module size up to 7.2 x 3.6m <p>Typical Applications</p> <ul style="list-style-type: none"> • Retail and industrial awnings • Verandahs, balconies (residential and high-rise buildings) • Car park canopies • Carports <p>Refer to “Installation” section.</p>
CEMINSEAL WALLBOARD SE CEILING SYSTEM - EXTERNAL & INTERNAL CEILING WITH EXPRESSED JOINTS		
		<p>Features</p> <ul style="list-style-type: none"> • External and internal applications • 6mm or 9mm CeminSeal Wallboard (SE) square edge sheets • All joints expressed – may be with or without sealant depending on application (refer to Table 4.02) • Top hats and furring channels fixed to timber or steel joists, trusses or suspension system • Sheet module size up to 1.2m x 3.6m • Framing control joint module size up to 7.2 x 3.6m <p>Typical Applications</p> <ul style="list-style-type: none"> • High humidity environments (indoor pools) • Verandahs & balconies (residential buildings) • Carports <p>Refer to “Installation” section.</p>
CEMINSEAL WALLBOARD RE CEILING SYSTEM - INTERNAL CEILING WITH FLUSH-SET JOINTS		
		<p>Features</p> <ul style="list-style-type: none"> • Internal applications • 6mm or 9mm CeminSeal Wallboard (RE) recessed edge lining • Flush-set joints • Furring channels fixed to timber or steel joists, trusses or suspension system • Sheet module size up to 5.2m x 6.0m • Framing control joint module size up to 10.4 x 6.0m <p>Typical Applications</p> <ul style="list-style-type: none"> • Sports halls • Secure areas • Industrial storage areas <p>Refer to “Installation” section.</p>



DESIGN + AESTHETIC
CONSIDERATIONS

DESIGN + AESTHETIC CONSIDERATIONS



System Selection/Wind Loading

External ceilings are subject to wind loads and the design of framing and fixings must be based on the project's site conditions. Factors that must be assessed to determine wind loading include the wind speed region, the terrain category in the vicinity of the site, and shielding from nearby buildings. Local pressure factors for the ceiling lining may also apply to some ceiling areas.

It is the responsibility of the building designer to determine the applicable pressures or 'Wind Classification' for the ceiling. Design span tables are provided for the CeminSeal Wallboard and Soffitline sheets and fixings to suit residential buildings within the scope of AS 4055 'Wind loads for housing' and for design to AS/NZS 1170.2 'Structural design actions, Part 2: Wind actions', for other buildings and structures.

Ceiling Framing

The CeminTel Ceiling Systems in this guide consist of a lining fixed to steel top hats or furring channels that are supported by structural framing. The structural framing may be timber or steel joists, rafters or trusses, or a suspension system.

As a minimum requirement, framing shall be in accordance with the following applicable standards:

- AS 1684 – Residential timber-framed construction.
- AS/NZS 4600 – Cold-formed steel structures.
- AS 3623 – Domestic metal framing.
- AS 4055 – Wind loads for housing.
- National Construction Code (NCC).

Soffitline and CeminSeal Wallboard sheets must not be fixed directly to the under side of roof framing or structural members. Steel top hats or furring channels must be used, such as Rondo No.129 with a minimum 0.55mm BMT and G2 steel grade, or equivalent or better properties must be used. Top hats and furring channels must have a minimum fixing face width of 35mm.

Framing set-out must be based on actual sheet lengths, with respect to the noted sheet tolerances. Correct design of the framework and sheet layout is important for the long term success of flush jointed installations.

Typically the ceiling system does not provide support to partition walls or items in the ceiling space, such as cable trays, pipework, ductwork, etc. These walls and items shall be independently supported by the primary structure, unless where applicable the ceiling framing is specifically designed to support the imposed loads. Note the applicable minimum clearances of AS/NZS 2785 or other project specification shall be maintained.

Timber Framing

Timber shall be seasoned or have reached an equilibrium moisture content of 16% or less at the time of framing. Unseasoned timber is not recommended.

Steel Framing

The design and construction of the steel frames should be considered in conjunction with the advice from the manufacturer. In highly corrosive environments, appropriate measures should be taken to protect the frame from corrosion. Refer to "Corrosivity Categories/Coastal Areas" in this guide, framing manufacturer guidance and project specifications of the project framing designer.

Steel framing must be a minimum 0.55mm BMT to a maximum 1.6mm BMT. Do not fix CeminTel sheets to thicker cold rolled members or to hot rolled steel.

Cemintel recommends contacting the project designer and/or steel components manufacturer, such as Rondo Technical Services, to verify the adequacy of the support framing design information before finalising the project design.

For external and internal ceiling applications, CeminTel recommends steel components manufactured by Rondo Building Services Pty Ltd. Other brands of equivalent or better performance may be used. It is the responsibility of the manufacturer of the steel component to substantiate equivalent or better performance than the recommended Rondo component.

Control Joints

To accommodate movement due to temperature and moisture effects, control joints in the framing are specified. Each system has a framing module, which indicates the spacing between framing control joints, and a sheet module, for additional sheet control joints.

Control joints must be provided in flush-set systems to allow for sheet movement. They must be installed at the specified sheet module and to coincide with control joints provided in the support framing. The supporting steel framing must be continuous with the 'flush-set' ceiling area and breaks in framing must be located at joints between the sheets. The designer must ensure the sheets are not continuous over movement joints in the support framing.

Sheet modules for exterior systems are given as multiples of single sheet sizes and must not be formed with smaller sheets that are joined.

Penetrations

Penetrations in the Cemintel ceiling sheets must be neatly cut using appropriate tools such as a saw, drill or hole saw. Penetrations should be prepared with a minimum clearance of 5mm all around and the gap should be filled with sealant where acoustic performance is required. The clearance gap should be capable of accommodating the expected differential movement between the partition wall or penetrating service, and ceiling sheets.

Insulation

Energy efficiency requirements for buildings are set out in the NCC as performance requirements and acceptable construction practices, and are dependant on geographical climate zones. Check with local building authorities for minimum insulation requirements.

For ceilings that form part of the building envelope, it is recommended that CSR Bradford insulation material is installed to meet energy requirements and improve occupant comfort. Insulation also improves the acoustic performance of the ceiling against outside noise. It is recommended that insulation values above the minimum be chosen for better energy conservation and occupant comfort.

In high humidity interior areas such as over pools, the design must be sufficient to ensure condensation does not occur.

For structures that do not require thermal insulation for energy efficiency, such as awnings and walkway canopies, it is recommended that insulation material is installed for condensation control. A suitable material is Bradford Anticon roofing blanket.

The level of insulation provided in a ceiling is described by its R-value. The higher the R-value the greater the insulation provided.

Refer to CSR Gyprock The Red Book 01 - Design Guide for thermal and acoustic performance values.

Corrosivity Categories/Coastal Areas

Corrosivity categories are detailed in AS 4312-2019 and set out in Table 4.03. The code has methods for determining categories as well as maps and tables of major population centres. The Architect/Building Designer is responsible for assessing the site in accordance with the standard and local conditions.

For joint details on system requirements in different environments refer to Table 4.02. It is the building designer's responsibility to determine the environmental zone, based on site conditions.

Due to limitations on the corrosion performance of steel framing, the designer shall confirm the durability adequacy of the steel framing system and joint type. The durability of the system can be increased by the additional treatment of steelwork, and by painting all exposed sealants to the sealant manufacturer's recommendations. In Corrosivity Category C4, sealants and other barriers are required to reduce the ingress of salt laden air.

Cemintel Soffitline and CeminSeal Wallboard are suitable for Corrosivity Categories up to and including C4 - High.

Indoor Pool Design Considerations

Consideration should be given to the corrosive environment around indoor swimming pools.

Measures should be implemented to avoid possible corrosion of the ceiling framing components and fixings from corrosive chemicals and moisture that may be present in the ceiling space.

In locations subject to excessive humidity and varying temperature range, Cemintel recommends the use of expressed joint ceiling systems only. The durability of the ceiling system may require sealing of the joints and/or painting of all exposed joints, refer to ceiling framing design requirements.

TABLE 4.02 System Requirements for Corrosive Environments

Corrosivity Category (AS4312-2008)	Ceiling Joint Type Options
C1 : Very Low	Flush-set, Expressed or Expressed with Sealant
C2 : Low	Flush-set, Expressed or Expressed with Sealant
C3 : Medium	Flush-set, Expressed or Expressed with Sealant
C4 : High	Flush-set or Expressed with Sealant



DESIGN + AESTHETIC CONSIDERATIONS

TABLE 4.03 General Descriptions of Corrosivity Categories

ISO 9223 Category	Corrosivity	Steel Corrosion rate $\mu\text{m}/\text{y}$	Typical environment
C1	Very low	<1.3	Dry indoors
C2	Low (most areas of Australia at least 50km from the coast or at least 1km from sheltered bays would be in this category)	1.3-25	Arid/urban inland
C3	Medium (from 1km to 10-50km from breaking surf – much of metropolitan Wollongong, Sydney, Newcastle and Gold Coast are in this category)	25-50	Coastal or industrial
C4	High (primarily coastal areas - from several hundred metres to about 1km inland from breaking surf or from the shoreline to around 50m for sheltered bays)	50-80	Sea shore (calm)
C5	Very high (industrial or marine) – common offshore and on the beachfront in regions of rough seas and surf beaches – can extend inland for several hundred metres (in some areas of Newcastle extends around 500m)	80-200	Sea shore (surf)
CX	Extreme (industrial or marine) - found on offshore structures and within 50m inland of the shoreline of coasts exposed to surf or very rough seas - can extend 200m under the most severe sea conditions and 100m in tropical locations.	200 - 700	Sea shore (severe surf) of exposed coasts

Building Renovations

When undertaking building renovations, remove all linings from the original framing. Ensure the condition of the framing is in accordance with current applicable requirements. Install additional framing where required as per details in this publication.

Painting

All products should be painted within three months of delivery to site. Cemintel recommends a minimum of two coats of appropriate acrylic paint be applied to the paint manufacturer’s specifications. A priming coat may also be required. Refer to paint manufacturer’s recommendations.

Where Cemintel products are exposed to the elements for more than three months from delivery, Cemintel recommends the application of a priming coat before applying the decorative coatings.

For ceilings over pools, a paint system resistant to the chemical atmosphere is required. Dulux recommends a three coat system of Sealer Binder and ENVIROPOXY™ WBE near chlorinated and saltwater pools. The paint manufacturer, instructions should be followed in all cases.

Prior to the application of the external coating, wash down exposed surfaces with clean fresh water to remove salt spray build-up from boards and fixings. Boards must be allowed to dry before coating.

Wash Down Process

An external coating system must be applied and maintenance of the coating system shall be in accordance with coating manufacturer’s recommendation. The following is recommended as a minimum maintenance regime:

- Ongoing maintenance should be limited to occasional rinse down or using a soft cloth or soft brush (like a dust pan brush).
- Protected ceilings shall be washed down to remove salt and debris build up particularly at joints, as required.
- Normal dirt can be removed with a soft brush and warm water up to 50 degrees, to which a small amount of dishwashing liquid or soap has been added.
- Calcifications should be removed with a 5% sulfamic acid solution or with a commercial lime remover. The ceiling should be rinsed with clear water after cleaning.
- Sheets discoloured by algal growth should be treated with an algicide without bleaching agents. This application should be allowed to take effect for several days.

Afterwards, clean the sheets using the ‘normal dirt’ procedure above.

04

DESIGN + AESTHETIC CONSIDERATIONS

- When rinsing down sheets, use no more than 700 psi (50kg/cm²) of water pressure at a minimum of 3m to 3.5m distance from the face of the wall. Water pressure should be applied downward to avoid forcing water into joints and gaps.
- Use neutral detergent with a soft cloth or soft brush when removing dirty spots from a sheet. When diluting the neutral detergent, follow the manufacturer's instructions and use the weakest solution possible.

Inspection, Repair and Maintenance

The durability of the Cemintel Ceiling System can be enhanced by periodic inspection and maintenance. Inspections should include examination of the coatings, flashings and seals. Any cracked or damaged finish or seals, which would allow water ingress must be repaired immediately by resealing the affected area, or by removing the panel and replacing sealant. Any damaged flashings, sheets or sealant must be replaced as for new work.

Regularly inspect sheet surfaces and follow wash-down procedures when required.

Ensure ventilation and drainage gaps between sheets and flashings are clear of any debris.



05











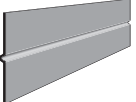

COMPONENTS + ACCESSORIES

05

COMPONENTS + ACCESSORIES

Note: Codes can change from time to time. Refer to the website for the current list of components prior to ordering.





Accessories

Product	Description	Size/Colour	Quantity	Product Code
	Cladding Nails for Timber Framing – Manually driven nails, Class 3 Hot Dipped Galvanised (HDG) or Class 4 Stainless Steel (S/S). Used for direct fixing CeminSeal Wallboard and Soffitline sheet cladding to timber framing.			
	Clout nail	2.8mmø x 40mm	2kg	77258
	Cladding Screws for Timber Framing – Used for direct fixing CeminSeal Wallboard and Soffitline sheet cladding to steel framing, furring channel or top hat battens. To suit 0.50mm BMT to 1.15mm BMT G2 framing.			
	SCROOZ Fasteners FibreFix Metal Cement Board Screws, self-embedding, SQ2-driver, Screw Armour Ceramic finish	8g x 32mm	Supplied by others	
	Cladding Screws for Steel Framing – Used for direct fixing CeminSeal Wallboard and Soffitline sheet cladding to steel framing, furring channel or top hat battens. Allowable steel framing thickness minimum 0.55mm BMT G550 steel grade, and 0.75mm BMT to 1.15mm BMT G2 steel grade.			
	TradeMark FibreDrill Tek 30mm - Self-drilling, CSK self-embedding head, Phillips drive Class 4	10g-18 x 30mm	1000 (loose)	492650
	Horizontal Backing Strip – Used for backing horizontal expressed joints between sheets. ExpressWall Backing Strip is manufactured from high tensile Colorbond steel, and is black in colour.			
		60 x 1194mmL	1	21089
		60 x 2394mmL	1	21088
		60 x 2994mmL	1	21087
	Gyprock Acrylic Stud Adhesive – Coloured blue for easy identification. It can be used on both timber and steel in temperatures not less than 5°C. Contact surfaces must be free of oil, grease or other foreign materials before application. The adhesive is applied with a broad knife. This product is suitable for use with pre-painted metal battens and some treated timbers. For internal ceiling applications only. Always follow directions on packaging when using CSR stud adhesive.			
		5.5kg bucket	1	10091
		1kg bucket	1	10090
		900g sausage	1	88618
	Gyprock Paper Tape – For strong invisible jointing.			
		75m	1	10589
		150m	1	10586
	Soffitline External Jointing Compound – For quality flush jointed exterior finishing. (Product still available)			
		15kg	1	85771
	Soffitline Topping Compound – For quality flush jointed exterior finishing. (Product still available)			
		15kg	1	95382
	Sealant Bond Breaker Tape – Used behind sealant filled board joints. Tesa Multifoam Tape N°7492, polyethylene closed cell foam tape. Self adhesive back.			
		48 x 3mm x 25mL	1	13172
	Flexible Sealant – Sikaflex®-PRO polyurethane sealant for sealed expressed joints, gaps around windows, doors and other penetrations. Paintable. Apply to manufacturer's specifications.			
		310 ml tube	1 x Grey	11378
		310 ml tube	1 x Black	39488
	Sealant Primer – Sika® Primer-3 N. Should be applied to surfaces prior to sealant to improve the long-term performance of joints. Apply to manufacturer's specifications.			
		250 ml	1	115227
	H-Moulding – PVC moulding for sheet joints.			
		2400mm	1	11253
		3000mm	1	11255
		3600mm	1	11256
	Trim-Tex Expansion Joint – 72-093V PVC moulding has flanges that act as a trowel guide. Tear off strips act as a guide for taping knives and protect the centre from plaster during jointing.			
		3000mm		10350

COMPONENTS + ACCESSORIES

05

Note: Codes can change from time to time. Refer to the website for the current list of components prior to ordering.

Product	Description	Size/Colour	Quantity	Product Code
	Trim-Tex UV Stabilised PVC Control Joint Bead (72-2710) – PVC moulding with a low profile that provides a full 6mm of movement. The soft centre “W” flexes as the structure expands and contracts. Tear off strips act as a guide for taping knives and protect the centre from plaster during jointing.	3m lengths	1 each	10351
	Trim-Tex Shadow Bead – 72-5390 PVC moulding provides 6 x 10mm shadowline. Tear off strip acts as a guide for taping knives and protects the reveal from plaster during jointing. To suit 6 and 9mm sheet.	3000mm		61021
CUTTING TOOLS				
	Makita Plunge Saw Kit (1300W) includes 1400mm guide rail and bonus 165mm fibre cement saw blade – excellent for cutting cement based sheets	165mm	1	165485
	Makita 165mm Fibre Cement Saw Blade – ideal for use with the Makita Plunge saw and other 165mm circular saws fitted with vacuum extraction systems	165mmx20x4T	1	165486
	Dust Extraction			



SYSTEM ENGINEERING

SYSTEM ENGINEERING



Design, Detailing And Performance Responsibilities

Cemintel engages independent testing laboratories to test and report on the performance of a wall, floor or ceiling in accordance with the relevant Australian Standards. Consultants use these reports as the basis for opinions (estimates of laboratory performance) they issue for variations or different arrangements to the tested system. Using their experience, the consultant will make judgement about on-site installed performance of various walls, floors or ceilings systems.

Project Consultants (Structural, Fire, Acoustic, Etc.)

These consultants are typically responsible for the following:

- Opinions on expected laboratory performance of wall, floor or ceiling configurations that vary from actual test configuration, such as substitution of products and components;
- Judgements about expected field performance using laboratory test reports and practical experience;
- Design, specification and certification of structural, fire, acoustic, durability, weather tightness and any other required performance criteria for individual projects;

The design and selection of building elements, such as walls, floors and ceilings and their integration into the building considering the following:

- Interface of different building elements including the structure/substrate;
- Wall and floor, wall and ceiling junctions;
- Penetrations;
- Flashing issues;
- Room / building geometry; and
- Acoustic and water penetration field-testing.

Design Responsibility

Cladding and linings, control layers (air, water, vapour), battens and top hats, insulation and structural framing are required to resist wind and earthquake loads that are specific to the building and the site. Additional 'local pressure factors' can apply to cladding and the supporting battens and top hats in accordance with the Australian Standard AS 4055 'Wind loads for housing' or AS/NZS 1170.2 'Structural design actions, Part 2: Wind actions'. It is recommended that the Architect/Building Designer assigns the responsibility for the façade design to the Project Engineer. Once loads have been determined, the battens and top hat spans, fastener spacing, air barrier construction details, and cladding fixing details may be selected from the appropriate tables in this guide and in the 'Cemintel Facades & Cladding Design Guide'. It is also the responsibility of the Architect / Building Designer to select the appropriate corrosivity category. Refer to appropriate details in this guide.

The performance levels of ceilings systems documented in this guide, the 'Cemintel Facades & Cladding Design Guide' and CSR Gyprock® The Red Book™ publications are either what is reported in a test or the documented opinion of consultants. Performance in projects is typically the responsibility of: **Project Certifier and/or Builder.**

These professionals are typically responsible for:

- Identifying the performance requirements for the project in accordance with the NCC and clearly communicating this to the relevant parties; and
- Applicability of any performance characteristics supplied by Cemintel including test and opinions for the project.

Cemintel does not provide consulting services. Cemintel provides technical information that has been prepared in consultation with third party subject expert consultants for the presentation of information presented in this guide, and therefore shall not be considered experts in the field. This guide may be subject to amendment or change as required or as deemed necessary. The most up to date version of this guide should be referred to and shall be available at the Cemintel website cemintel.com.au.

Any party using the information contained in this guide or supplied by Cemintel in the course of a project must satisfy themselves that it is true, current and appropriate for the application, consequently accepting responsibility for its use.

It is the responsibility of the building designer, architect, engineer and project consultants to ensure that the information and details in this guide and the performance of the Cemintel ceiling system is suitable for the intended project application.

The recommendations in this guide are formulated along the lines of good building practice but are not intended to be an exhaustive statement of all relevant data.

Cemintel is not responsible for the performance of constructed walls, including field performance, and does not interpret or make judgements about performance requirements in the NCC in a specific project application.

Note: It is the responsibility of the Project Engineer/ Frame Designer to specify the structural sub-framing that supports the furring channel or top hat sections supporting the Cemintel Wallboard and Cemintel Soffitline sheets. It is also the responsibility of the project engineer to calculate the wind loads and earthquake loads for the cladding, air barrier and support framing of the façade on a project.



SYSTEM ENGINEERING

Design Information

The design tables of Cemintel Soffitline and CeminSeal Wallboard sheets are presented in two formats:

- Limit State format and for use with AS/NZS 1170.2; and
- Wind Classification for use with AS 4055 applicable residential buildings.

The building designer must calculate the appropriate design loads and/or Wind Classification to determine the maximum fastener spacing for fixing the ceiling sheets, and allowable support framing span and spacing distances from the framing manufacturer. Refer to Design Considerations for assumptions made for system design.

To obtain the maximum Serviceability Limit State Wind Pressure, divide the “Design Ultimate Limit State Wind Pressure” by 1.5.

The design wind pressures acting on the external ceiling are influenced by the wall enclosure arrangement of the external awning. These arrangements are shown in Figure 6.01, Figure 6.02 and Figure 6.03. For the AS4055 design table, following are the structural design parameters:

- Imposed wind loads use the following maxima pressure coefficient values in accordance with AS4055-2021:
 - Internal pressures (ceilings):

N1 to N6:	0.3
C1 to C4:	0.7

- External pressures (ceilings):

Two sides enclosed:	+1.0
Unenclosed verandas:	+1.5
Three sides enclosed:	+/- 1.2

- Bending moments and deflections based on worse-case coefficients for 2-, 3- and 4-span continuous sheets and imposed loading, with a maximum deflection ratio of span/200.
- Imposed seismic loads use the maximum requirements of Equation 8.2(1) of AS 1170.4-2007.

The connection of top hats or furring channels to structural framing is to be in accordance with the project designer and/or manufacturer instructions. For internal applications, the Rondo furring channels are connected to the structural framing via Rondo P226 or P394 direct-fix clips or a Rondo Key-Lock suspended ceiling system. For external applications and the associated higher wind pressures, the Rondo ceiling framing solution could require design modification, such as the inclusion of down-struts.

Cemintel recommends contacting Rondo Technical Services Pty Ltd for design advice and technical information on the various ceiling systems. Additional information can be obtained from Rondo, telephone 1300-367-663.

Guide to Wind Load Tables

These tables are applicable to residential buildings within the scope of AS4055.

FIGURE 6.01 Two Sides Enclosed
Net Wind Pressure Coefficient,
 $C_{pn} = 1.0$

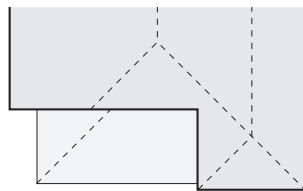

FIGURE 6.02 Unenclosed Verandah
Net Wind Pressure Coefficient,
 $C_{pn} = 1.5$

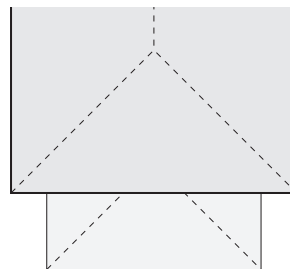
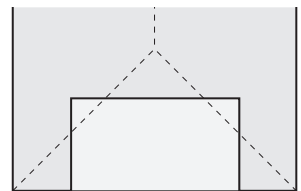

FIGURE 6.03 Three Sides Enclosed
Net Wind Pressure Coefficient,
 $C_{pn} = \pm 1.2$



SYSTEM ENGINEERING



SCREW FASTENER DESIGN TABLES

TABLE 6.01 Maximum Screw Fastener Spacing for 6mm CeminSeal Wallboard and 6mm Soffitline - AS/NZS 1170.2 Design Wind Pressures

Frame Spacing (mm)	Design Ultimate Limit State Wind Pressure (kPa)	Maximum Fastener Spacing (mm)			
		External Ceiling Applications		Internal Ceiling Applications	
		Insulation		Insulation	
		0 kg/m ²	5 kg/m ²	0 kg/m ²	5 kg/m ²
300	0.5	300	300	300	300
	1	300	300	300	300
	1.5	300	300	300	300
	2	300	300	300	300
	2.5	300	300	300	300
	3	250	250	250	250
	3.5	200	200	200	200
450	0.5	300	300	300	300
600	0.05	300	300	300	300
	0.1	300	300	300	300
	0.15	300	300	300	300
	0.2	300	300	300	300
	0.25	300	300	300	300
	0.3	300	-	300	-

TABLE 6.02 Maximum Screw Fastener Spacing for 6mm CeminSeal Wallboard and 6mm Soffitline - AS4055 Wind Classifications

Frame Spacing (mm)	Wind Classification	Maximum Fastener Spacing (mm)							
		External Ceiling Applications						Internal Ceiling Applications	
		Awning and Enclosure Type						Enclosure Type	
		Two Sides Enclosed	Unenclosed Verandah	Three Sides Enclosed	Two Sides Enclosed	Unenclosed Verandah	Three Sides Enclosed	Four Sides Enclosed	
		Insulation 0 kg/m ²			Insulation 5 kg/m ²			0 kg/m ²	5 kg/m ²
300	N1	300	300	300	300	300	300	300	300
	N2	300	300	300	300	300	300	300	300
	N3	300	300	300	300	300	300	300	300
	N4	300	250	300	300	250	300	300	300
	N5	250	150	200	250	150	200	300	300
	N6	150	-	150	200	-	150	300	300
	C1	300	300	300	300	300	300	300	300
	C2	300	250	300	300	250	300	300	300
	C3	250	150	200	250	150	200	300	300
	C4	150	-	150	200	-	150	250	250
450	N1	300	300	300	300	300	300	300	300
	N2	300	300	300	300	300	300	300	300
	N3	300	-	-	300	-	-	300	300
	N4	-	-	-	-	-	-	300	300
	N5	-	-	-	-	-	-	300	300
	N6	-	-	-	-	-	-	300	300
	C1	300	-	-	300	-	-	300	300
	C2	-	-	-	-	-	-	300	-
600	N1	-	-	-	300	-	-	300	300
	N2	-	-	-	300	-	-	300	300
	N3	-	-	-	-	-	-	300	300



SYSTEM ENGINEERING

SCREW FASTENER DESIGN TABLES

TABLE 6.03 Maximum Screw Fastener Spacing for 9mm CeminSeal Wallboard
- AS/NZS 1170.2 Design Wind Pressures

Frame Spacing (mm)	Design Ultimate Limit State Wind Pressure (kPa)	Maximum Fastener Spacing (mm)			
		External Ceiling Applications		Internal Ceiling Applications	
		Insulation		Insulation	
		0 kg/m ²	5 kg/m ²	0 kg/m ²	5 kg/m ²
300	0.5	300	300	300	300
	1	300	300	300	300
	1.5	300	300	300	300
	2	300	300	300	300
	2.5	300	300	300	300
	3	300	300	300	300
	3.5	300	300	300	300
	4	300	300	300	300
	4.5	300	300	300	300
	5	300	300	300	300
	5.5	300	300	300	300
	6	250	250	250	250
	6.5	250	250	250	250
7	200	200	200	200	
450	0.5	300	300	300	300
	1	300	300	300	300
	1.5	300	300	300	300
	2	300	300	300	300
	2.5	300	300	300	300
	3	300	300	300	300
	3.5	300	-	300	-
600	0.5	300	300	300	300
	1	300	300	300	300



SYSTEM ENGINEERING

NAIL FASTENER DESIGN TABLES

TABLE 6.05 Maximum Nail Fastener Spacing for 6mm CeminSeal Wallboard and 6mm SoffitLine - AS/NZS 1170.2 Design Wind Pressures

Frame Spacing (mm)	Design Ultimate Limit State Wind Pressure (kPa)	Maximum Fastener Spacing (mm)			
		External Ceiling Applications		Internal Ceiling Applications	
		Insulation		Insulation	
		0 kg/m ²	5 kg/m ²	0 kg/m ²	5 kg/m ²
300	0.5	300	300	300	300
	1	300	300	300	300
	1.5	250	250	250	250
	2	200	200	200	200
	2.5	150	150	150	150
	3	100	100	100	100
450	0.5	300	300	300	300
	1	-	-	-	-
600	0.05	300	300	300	300
	0.1	300	300	300	300
	0.15	300	300	300	300
	0.2	300	300	300	300
	0.25	300	300	300	300
	0.3	300	-	300	-

TABLE 6.06 Maximum Nail Fastener Spacing for 6mm CeminSeal Wallboard and 6mm SoffitLine - AS4055 Wind Classifications

Frame Spacing (mm)	Wind Classification	Maximum Fastener Spacing (mm)							
		External Ceiling Applications						Internal Ceiling Applications	
		Awning and Enclosure Type						Enclosure Type	
		Two Sides Enclosed	Unenclosed Verandah	Three Sides Enclosed	Two Sides Enclosed	Unenclosed Verandah	Three Sides Enclosed	Four Sides Enclosed	
		Insulation 0 kg/m ²			Insulation 5 kg/m ²			0 kg/m ²	5 kg/m ²
300	N1	300	300	300	300	300	300	300	300
	N2	300	300	300	300	300	300	300	300
	N3	300	200	200	300	200	200	300	300
	N4	200	100	150	200	100	150	300	300
	N5	100	-	100	100	-	100	300	300
	N6	100	-	-	100	-	-	300	250
	C1	300	200	200	300	200	200	300	300
	C2	200	100	150	200	100	150	250	250
	C3	100	-	100	100	-	100	150	150
	C4	100	-	-	100	-	-	100	100
450	N1	300	300	300	300	300	250	300	300
	N2	300	200	200	300	200	200	300	300
	N3	200	-	-	200	-	-	300	300
	N4	-	-	-	-	-	-	300	300
	N5	-	-	-	-	-	-	250	250
	N6	-	-	-	-	-	-	200	150
	C1	200	-	-	200	-	-	250	200
	C2	-	-	-	-	-	-	150	-
600	N1	-	-	-	300	-	-	300	300
	N2	-	-	-	300	-	-	300	300
	N3	-	-	-	-	-	-	300	300

SYSTEM ENGINEERING



NAIL FASTENER DESIGN TABLES

TABLE 6.07 Maximum Nail Fastener Spacing for 9mm CeminSeal Wallboard - AS/NZS 1170.2 Design Wind Pressures

Frame Spacing (mm)	Design Ultimate Limit State Wind Pressure (kPa)	Maximum Fastener Spacing (mm)			
		External Ceiling Applications		Internal Ceiling Applications	
		Insulation		Insulation	
		0 kg/m ²	5 kg/m ²	0 kg/m ²	5 kg/m ²
300	0.5	300	300	300	300
	1	300	300	300	300
	1.5	250	250	250	250
	2	200	150	200	150
	2.5	150	150	150	150
	3	100	100	100	100
	3.5	100	100	100	100
450	4	100	100	100	100
	0.5	300	300	300	300
	1	250	200	250	200
	1.5	150	150	150	150
	2	100	100	100	100
600	2.5	100	100	100	100
	0.5	300	300	300	300
	1	150	150	150	150
	1.5	-	-	-	-



SYSTEM ENGINEERING

NAIL FASTENER DESIGN TABLES

TABLE 6.08 Maximum Nail Fastener Spacing for 9mm CeminSeal Wallboard - AS4055 Wind Classifications

Frame Spacing (mm)	Wind Classification	Maximum Fastener Spacing (mm)							
		External Ceiling Applications						Internal Ceiling Applications	
		Awning and Enclosure Type						Enclosure Type	
		Two Sides Enclosed	Unenclosed Verandah	Three Sides Enclosed	Two Sides Enclosed	Unenclosed Verandah	Three Sides Enclosed	Four Sides Enclosed	
		Insulation 0 kg/m ²			Insulation 5 kg/m ²			0 kg/m ²	5 kg/m ²
300	N1	300	300	300	300	300	300	300	300
	N2	300	300	300	300	300	300	300	300
	N3	300	200	200	300	200	200	300	300
	N4	200	100	150	200	100	150	300	300
	N5	100	-	100	100	-	100	300	300
	N6	100	-	-	100	-	-	250	250
	C1	300	200	200	300	200	200	300	300
	C2	200	100	150	200	100	150	250	200
	C3	100	-	100	100	-	100	150	150
	C4	100	-	-	100	-	-	100	100
450	N1	300	300	250	300	300	250	300	300
	N2	300	200	200	300	200	200	300	300
	N3	200	100	150	200	100	100	300	300
	N4	100	-	100	100	-	100	300	300
	N5	-	-	-	-	-	-	250	200
	N6	-	-	-	-	-	-	150	150
	C1	200	100	150	200	100	100	200	200
	C2	100	-	100	100	-	100	150	150
	C3	-	-	-	-	-	-	100	100
	C4	-	-	-	-	-	-	-	-
600	N1	300	200	200	300	200	200	300	300
	N2	250	150	150	250	150	150	300	300
	N3	150	100	100	150	100	100	300	300
	N4	100	-	-	100	-	-	250	200
	N5	-	-	-	-	-	-	150	150
	N6	-	-	-	-	-	-	100	100
	C1	150	100	100	150	100	100	150	150
	C2	100	-	-	100	-	-	100	100

07

INSTALLATION, CONSTRUCTION
DRAWINGS + DETAILS



Check quality and quantity of sheets and components before installing. If there is any sign of damage or visible defects in sheets, or the colour/finish is not in keeping with the owners aesthetic requirements DO NOT INSTALL. Contact Cemintel to address any issues.

SHEET INSTALLATION

All Soffitline and Wallboard sheets are to be installed with long edges across the framing. Butt joints, where permitted, must be staggered a minimum of 600mm in adjacent sheets and must occur at the support framing.

Avoid setting sheet joints near openings such as skylights. Where these are unavoidable, they are to be positioned a minimum 200mm from corners of the openings.

Fasteners are to be positioned a minimum of 12mm from the edge of the sheet for recessed edges that are set, and 20mm from other edges. Fasteners are to be a minimum 50mm from sheet corners and are to be installed approximately 0.5mm below the sheet surface.

Other edges that require a 20mm minimum edge distance for fasteners, include the square edge (SE) of sheets and recessed edge (RE) at control joints where there is a sheet control joint or a movement gap between the sheets.

FIGURE 7.01 Fastener Positioning – CeminSeal Wallboard

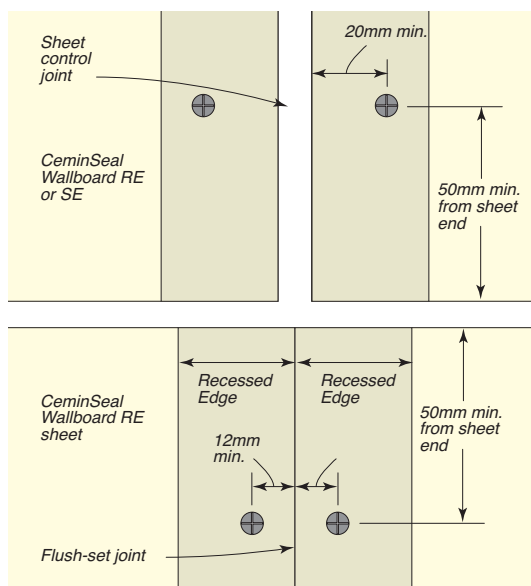
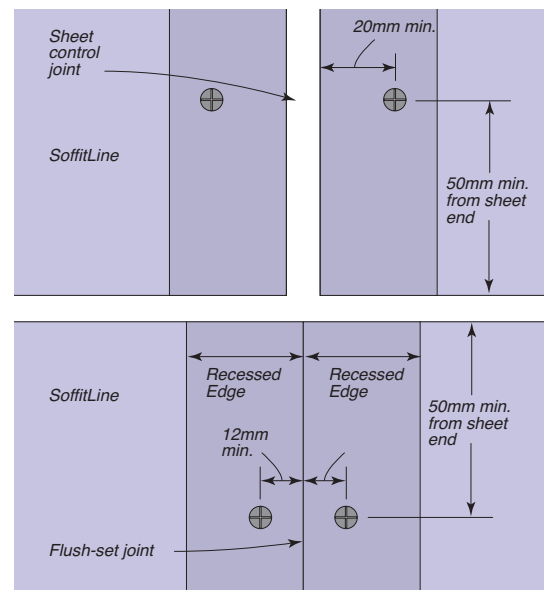

FIGURE 7.02 Fastener Positioning – Soffitline



INSTALLATION, CONSTRUCTION DRAWINGS + DETAILS



INTERNAL CEILING SYSTEMS

Internal ceiling systems with a 6mm CeminSeal Wallboard RE lining may be installed using the combination adhesive/ fastener fixing system as detailed in Figure 7.03. The adhesive/ fastener fixing system can be used for design ultimate internal wind pressures up to 1 kPa. For design ultimate internal wind pressures greater than 1kPa use the full fastener fixing system as detailed in Figure 7.04. **For a maximum screw spacing less than 300mm**, the maximum adhesive spacing and maximum screw spacing at the end of the sheet shall be 2/3 of the screw spacing (i.e., 200mm screw spacing would be 125mm adhesive spacing).

FIGURE 7.03 Adhesive/Fastener Fixing System for Internal Flush-set Ceiling Systems - CeminSeal Wallboard RE

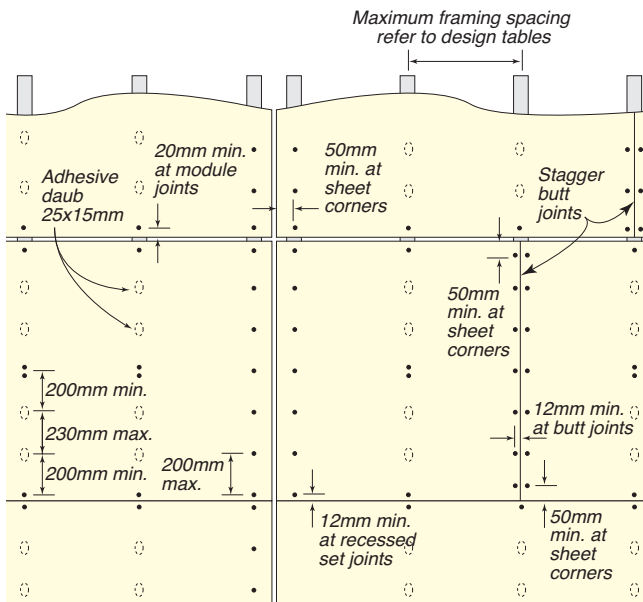
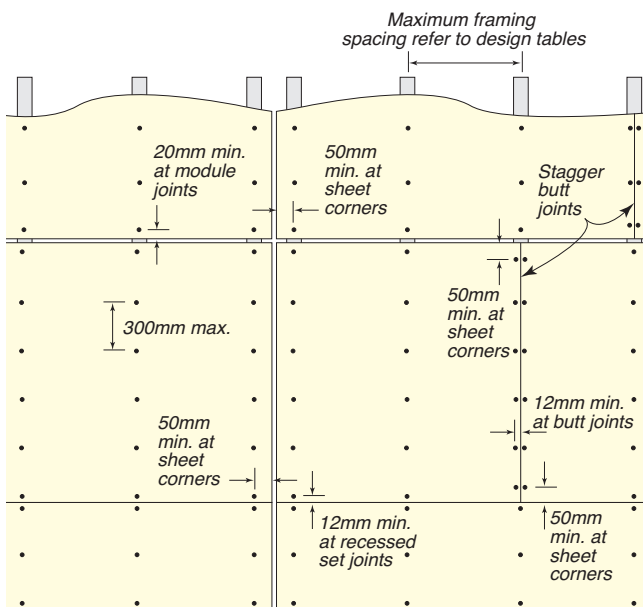

FIGURE 7.04 Fastener Fixing System for Internal Flush-set Ceiling Systems - CeminSeal Wallboard RE



Refer to Table 6.01 to 6.04 for the maximum allowable fastener spacing for a range of furring channels and top hats spacings, to satisfy the imposed design loads.

EXTERNAL CEILING SYSTEMS

External ceiling systems must be installed using the all fastener fixing system as detailed in Figure 7.05 or Figure 7.06.

Refer to TABLE 6.06 to 6.04 for the maximum allowable fastener spacing for a range of furring channels and top hats spacings, to satisfy the imposed design loads.

FIGURE 7.05 Fastener Fixing System for External Flush-set Ceiling Systems - Soffitline

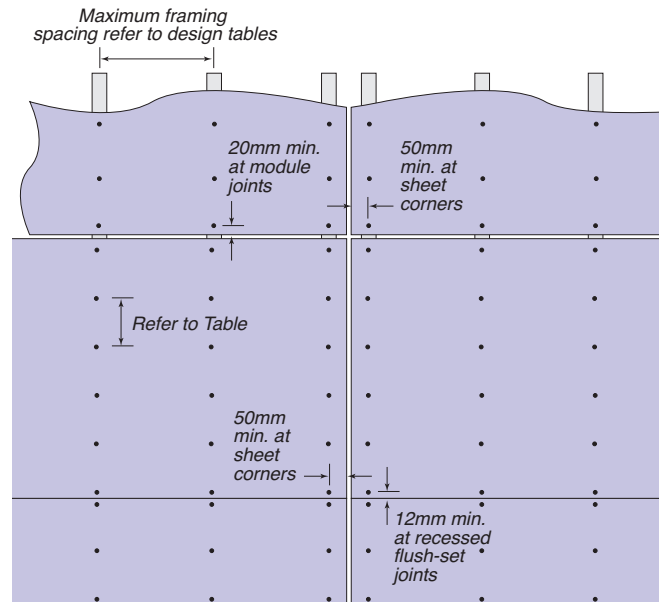
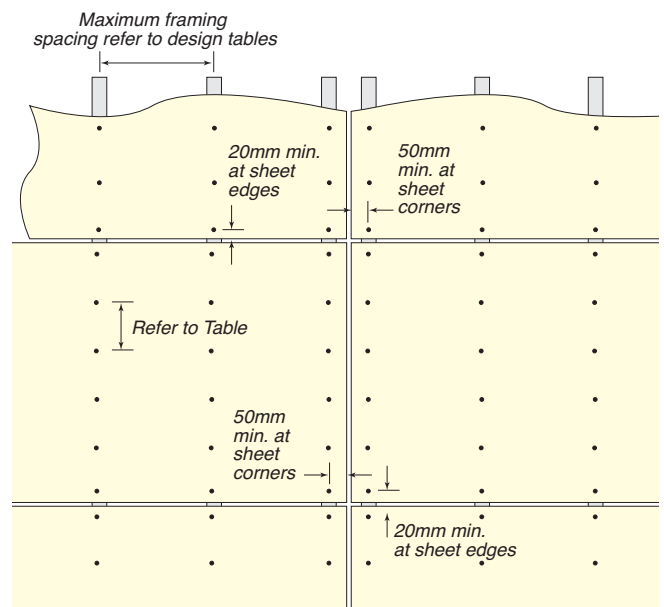

FIGURE 7.06 Fastener Fixing System for External Exposed Joint Ceiling Systems - CeminSeal Wallboard SE



INSTALLATION DETAILS FOR SOFFITLINE CEILING SYSTEMS - EXTERNAL CEILING WITH FLUSH-SET JOINTS

Features

- 6mm Soffitline recessed edge lining
- Flush-set joints
- Top hats and furring channels fixed to timber or steel joists, trusses or suspension system
- Sheet module size up to 3.6m x 3.6m
- Framing control joint module size up to 7.2m x 3.6m

Typical Applications

- Retails and industrial awnings
- Verandahs, balconies (residential and high-rise buildings)
- Car park canopies
- Carports

FIGURE 8.01 Typical Layout for Soffitline Ceiling System - External Ceiling with Flush-Set Joints

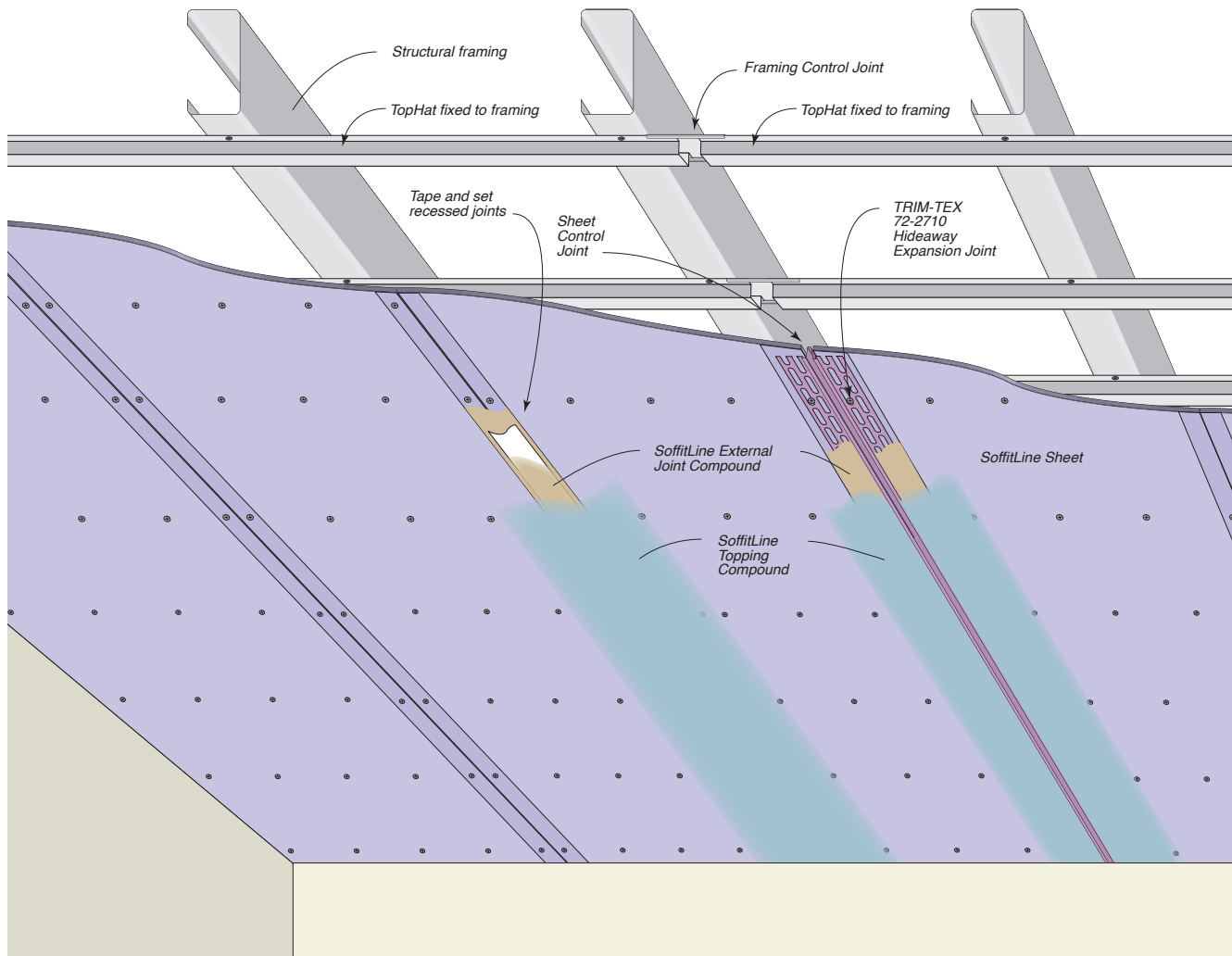

INSTALLATION, CONSTRUCTION DRAWINGS + DETAILS



**INSTALLATION DETAILS FOR SOFFITLINE CEILING SYSTEMS –
EXTERNAL CEILING WITH FLUSH-SET JOINTS**

FIGURE 8.02 Soffitline Ceiling System – External Ceiling with Flush-Set Joints

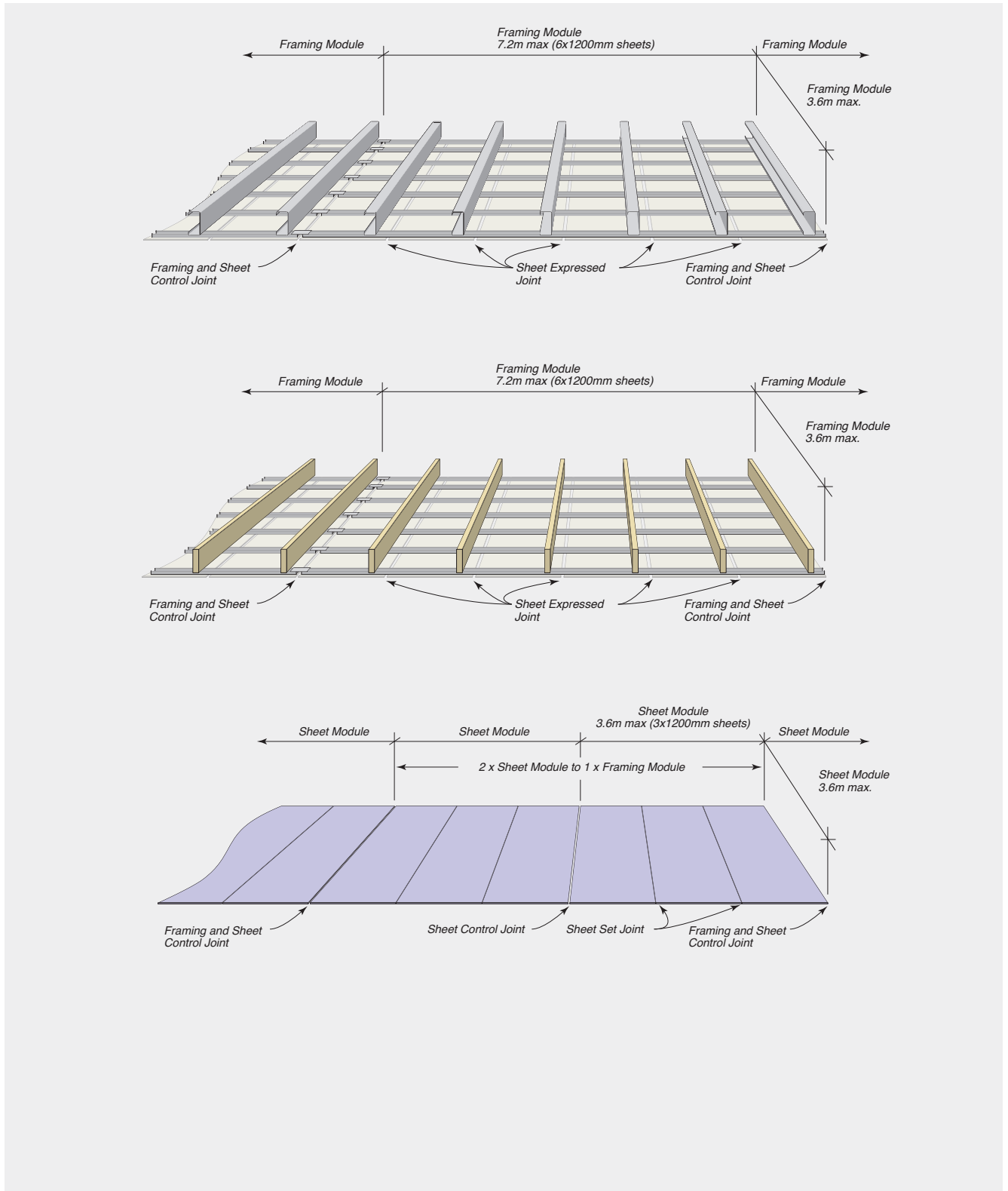

INSTALLATION DETAILS FOR SOFFITLINE CEILING SYSTEMS - EXTERNAL CEILING WITH FLUSH-SET JOINTS

FIGURE 8.03 Sheet Module Control Joint

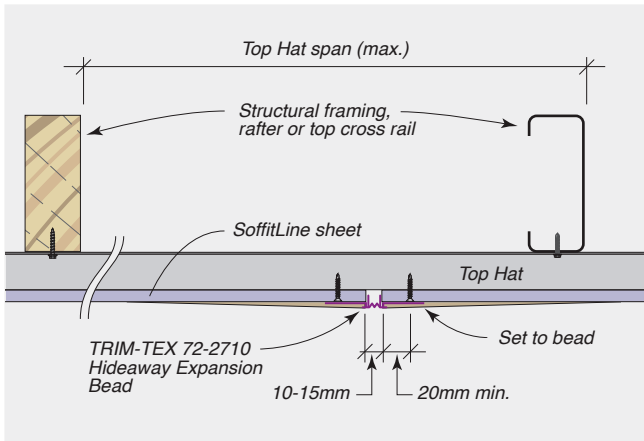

FIGURE 8.05 Sheet Set Joint

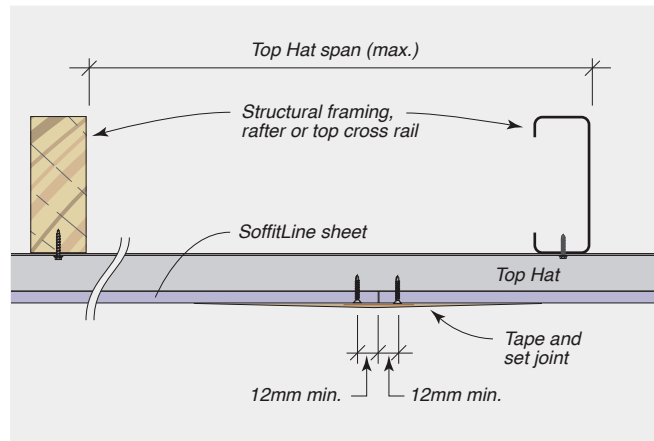

FIGURE 8.04 Joining of Top Hat

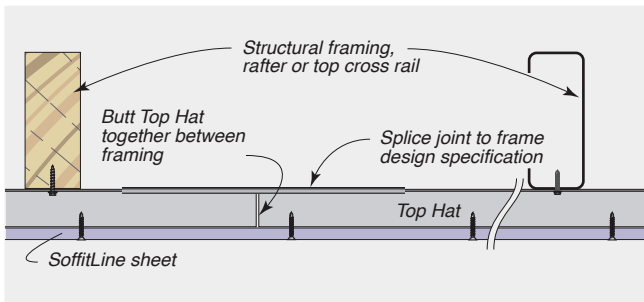
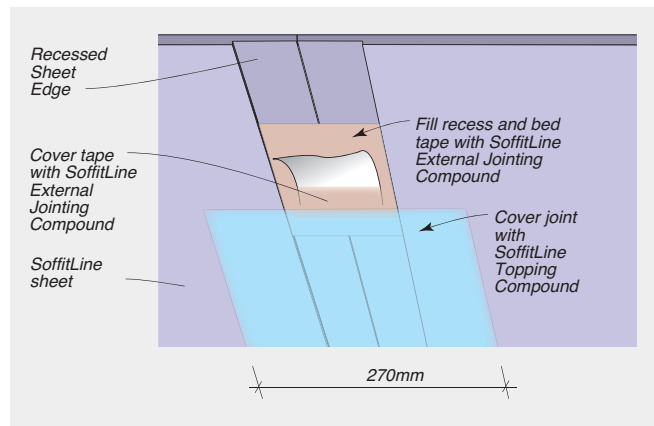

FIGURE 8.06 Flush-Set Jointing - External Soffitline System
Recessed Joint. (Refer to the JOINTING section in this
guide for more detailed information)



Installation Tip:

Avoid the use of excess compounds to reduce sanding requirements.

INSTALLATION, CONSTRUCTION DRAWINGS + DETAILS



INSTALLATION DETAILS FOR EXTERNAL AND INTERNAL CEILING SYSTEMS – WITH EXPRESSED JOINTS

Features

- 6mm or 9mm CeminSeal Wallboard (SE) square edge sheets
- All joints expressed – may be with or without sealant depending on application (refer to TABLE 4.02)
- Internal applications - furring channels fixed to timber or steel joists, trusses or suspension system
- External applications - furring channels or top hats fixed to timber or steel joists, trusses or suspension system
- Sheet module size up to 1.2m x 3.6m
- Framing control joint module size up to 7.2m x 3.6m

Typical Applications

- High humidity environments (indoor pools)
- Verandahs & balconies (residential buildings)
- Carports

FIGURE 8.07 Typical Layout for Internal Ceiling with Expressed Joints

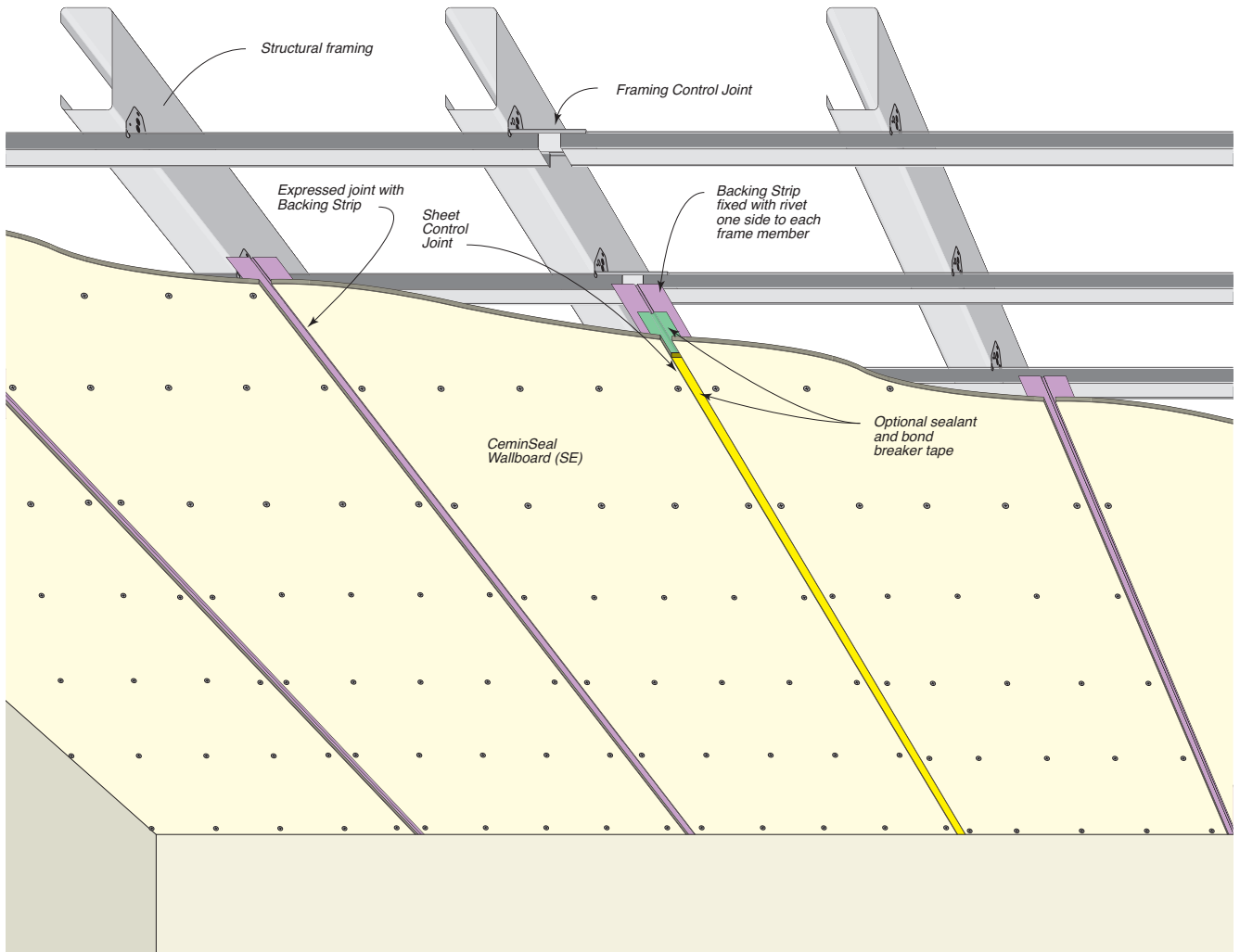

INSTALLATION DETAILS FOR EXTERNAL AND INTERNAL CEILING SYSTEMS - WITH EXPRESSED JOINTS

FIGURE 8.08 Internal Ceiling with Expressed Joints

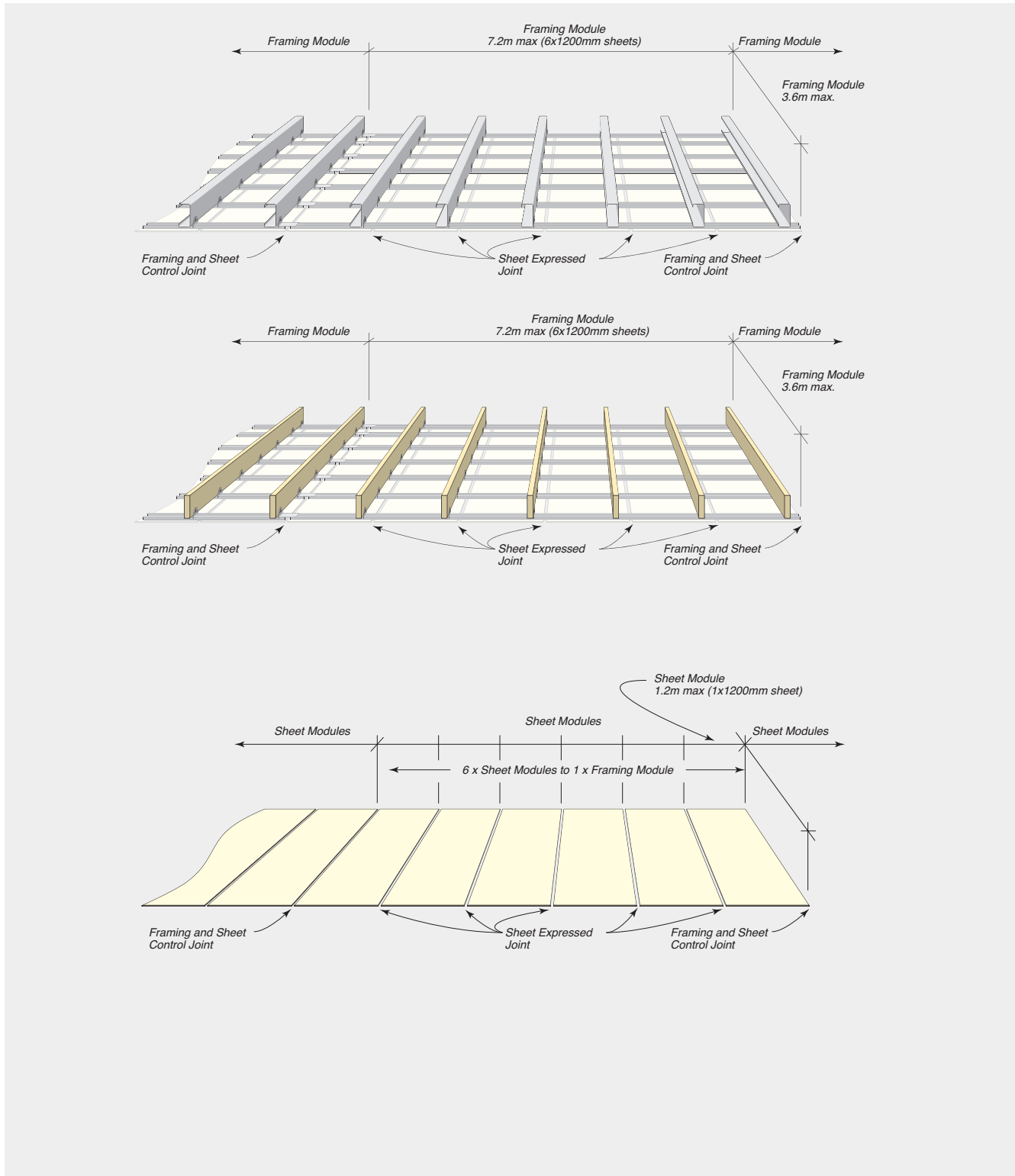

INSTALLATION, CONSTRUCTION DRAWINGS + DETAILS

INSTALLATION DETAILS FOR INTERNAL CEILING SYSTEMS – WITH EXPRESSED JOINTS

FIGURE 8.09 Perimeter Detail – Expressed Joint

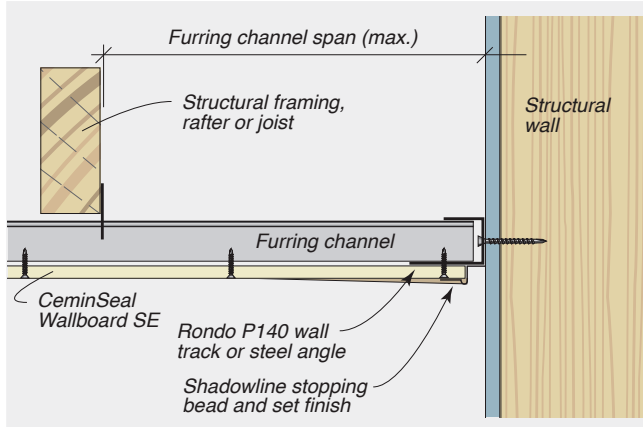

FIGURE 8.12 Sheet Module Control Joint – Expressed Joint

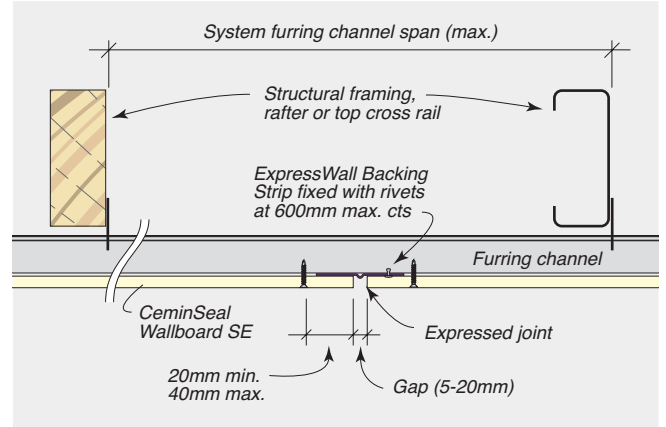

FIGURE 8.10 Perimeter Detail – Expressed Joint

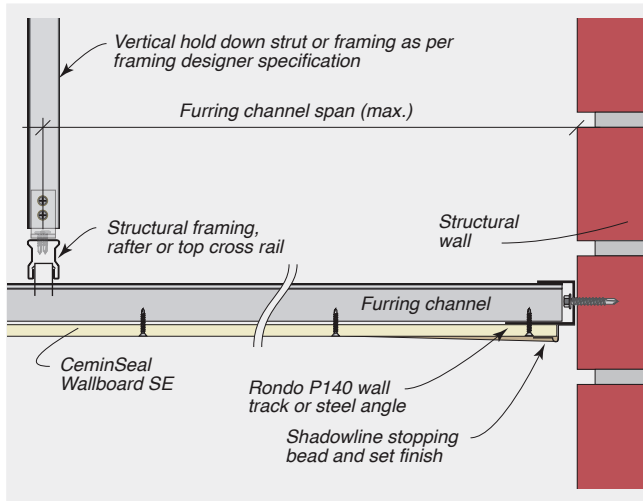

FIGURE 8.13 Perimeter Detail – Expressed Joint

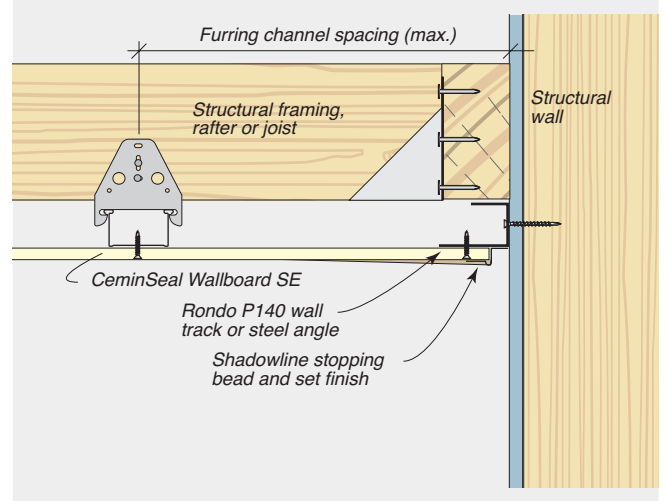

FIGURE 8.11 Framing & Sheet Module Control Joint – Expressed Joint

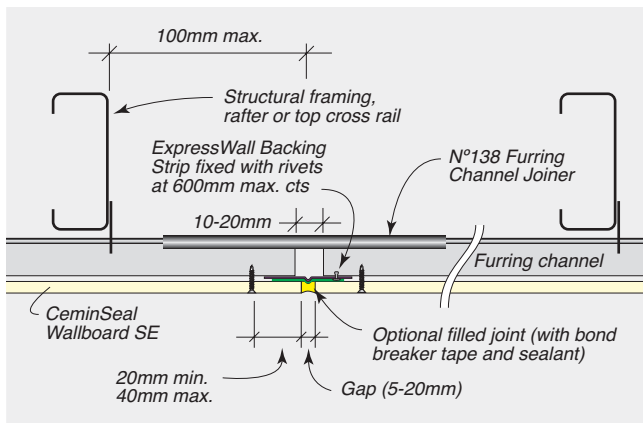
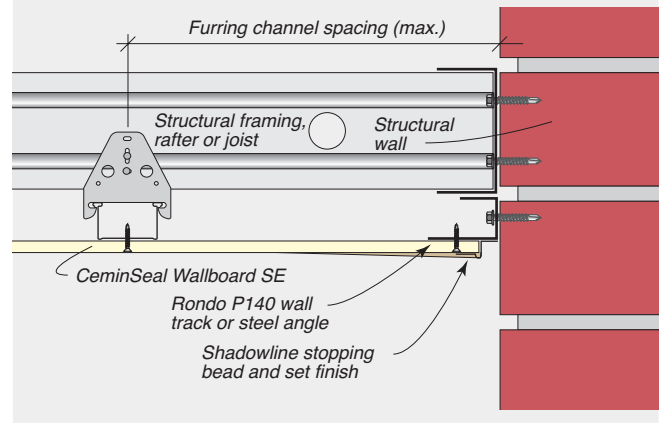

FIGURE 8.14 Perimeter Detail – Expressed Joint



INSTALLATION DETAILS FOR INTERNAL CEILING SYSTEMS - WITH EXPRESSED JOINTS

FIGURE 8.15 Framing and Sheet Module Control Joint - Exposed Joint

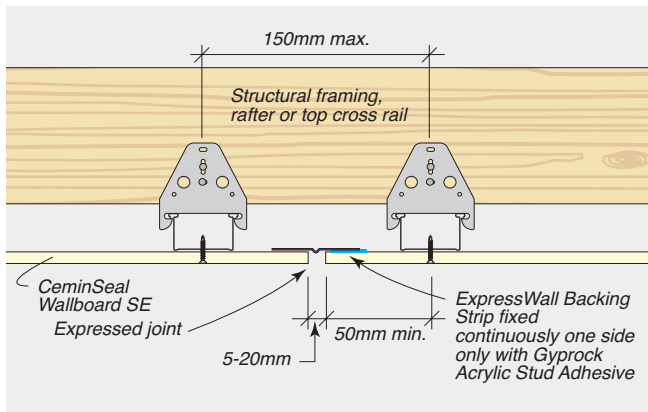

FIGURE 8.18 Sheet Module Control Joint - H-Mould Joint

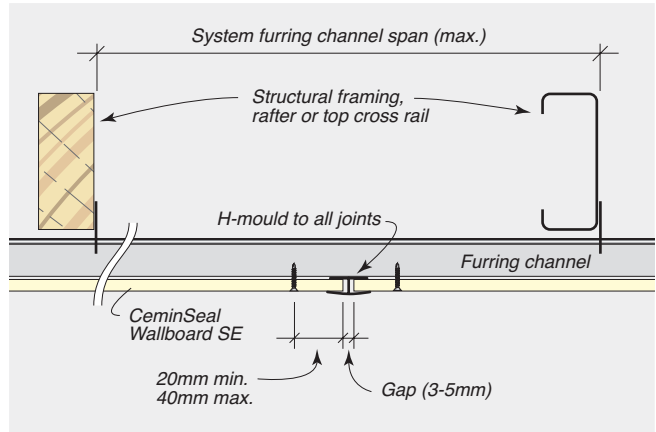

FIGURE 8.16 Framing and Sheet Module Control Joint - Exposed Joint - Alternative

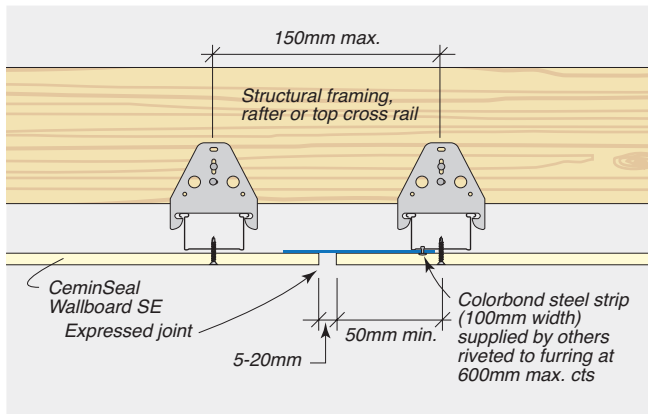

FIGURE 8.19 Framing and Sheet Module Control Joint - H-Mould Joint

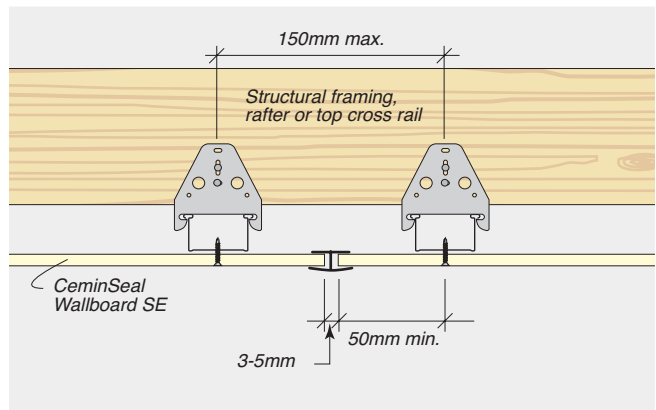
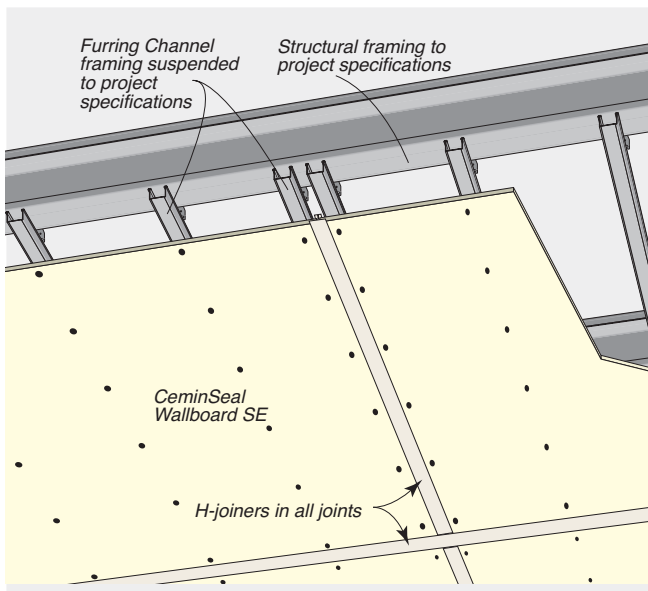

FIGURE 8.17 Sheet Module Control Joint - H-Mould Joint



INSTALLATION, CONSTRUCTION DRAWINGS + DETAILS



INSTALLATION DETAILS FOR EXTERNAL CEILING SYSTEMS – WITH EXPRESSED JOINTS

FIGURE 8.20 Typical Fascia and Soffit Detail - External Installation

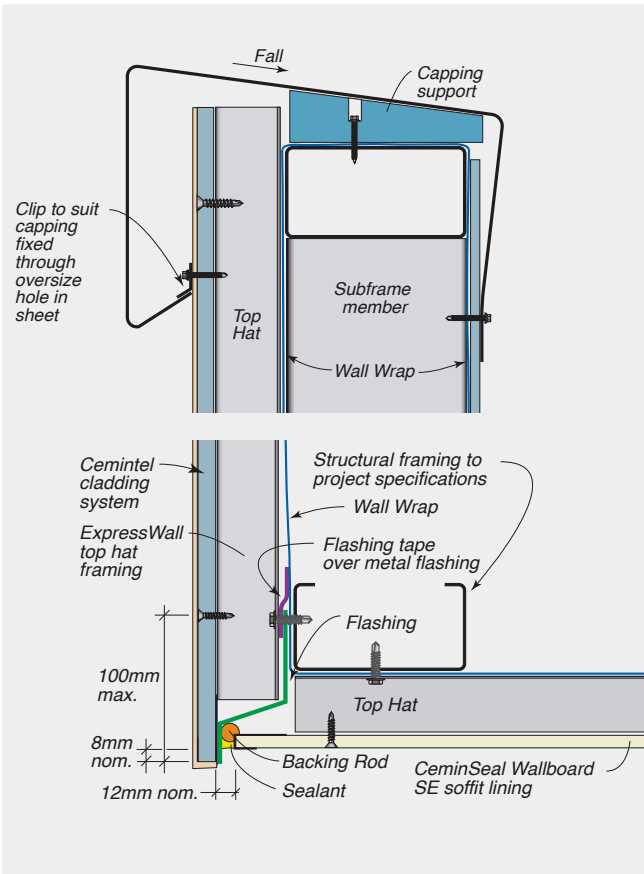

INSTALLATION DETAILS FOR INTERNAL CEILING SYSTEMS - WITH FLUSH-SET JOINTS

Features

- 6mm or 9mm CeminSeal Wallboard (RE) recessed edge lining
- Flush-set joints
- Furring channels fixed to timber or steel joists, trusses or suspension system
- Sheet module size up to 5.2m x 6.0m
- Framing control joint module size up to 10.4m x 6.0m

Typical Applications

- Sports halls
- Secure areas
- Industrial storage areas

FIGURE 8.21 Typical Layout for Internal Ceiling with Flush-Set Joints

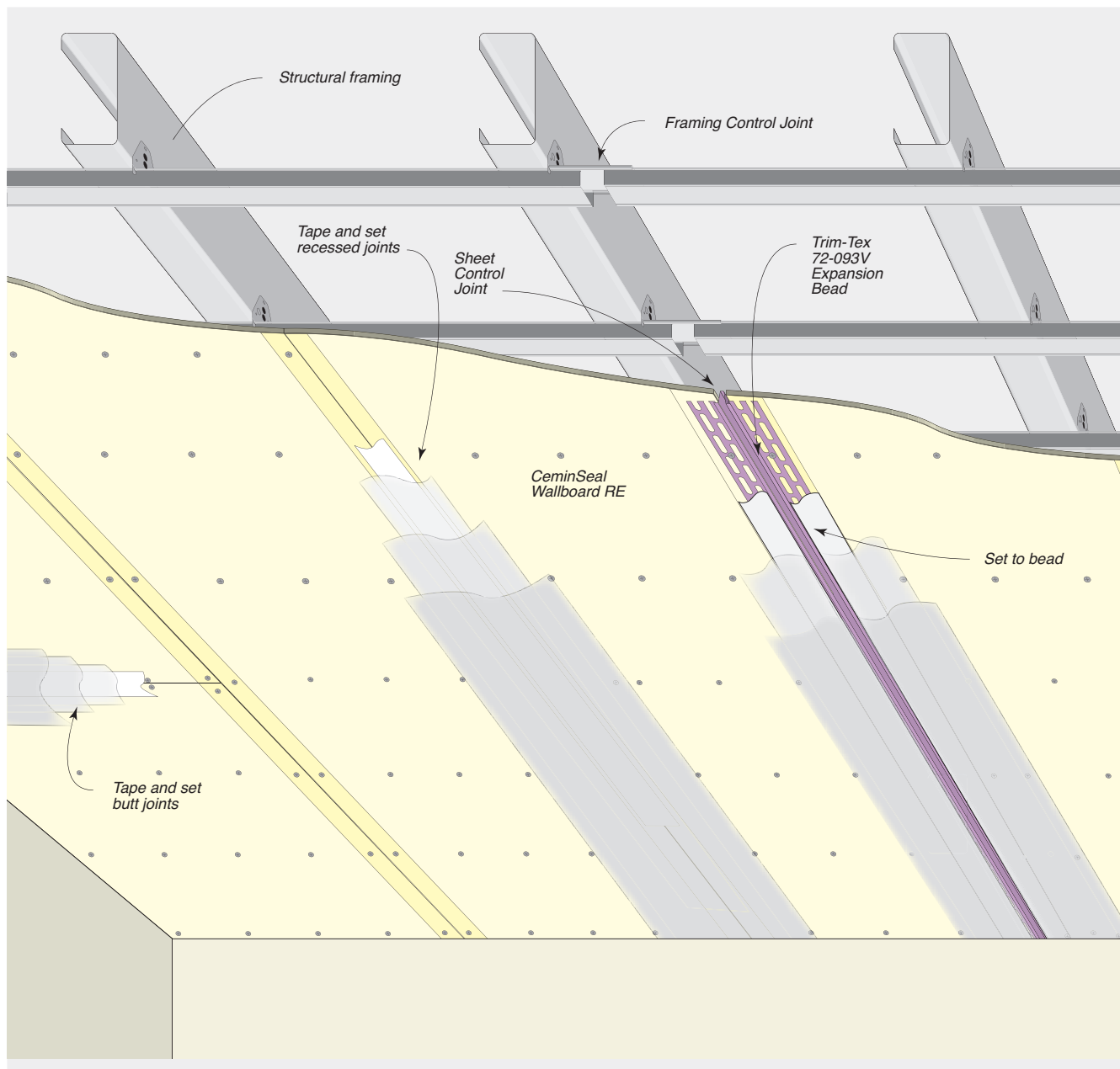

INSTALLATION, CONSTRUCTION DRAWINGS + DETAILS



INSTALLATION DETAILS FOR INTERNAL CEILING SYSTEMS – WITH FLUSH-SET JOINTS

FIGURE 8.22 Internal Ceiling Systems with Flush-Set Joints

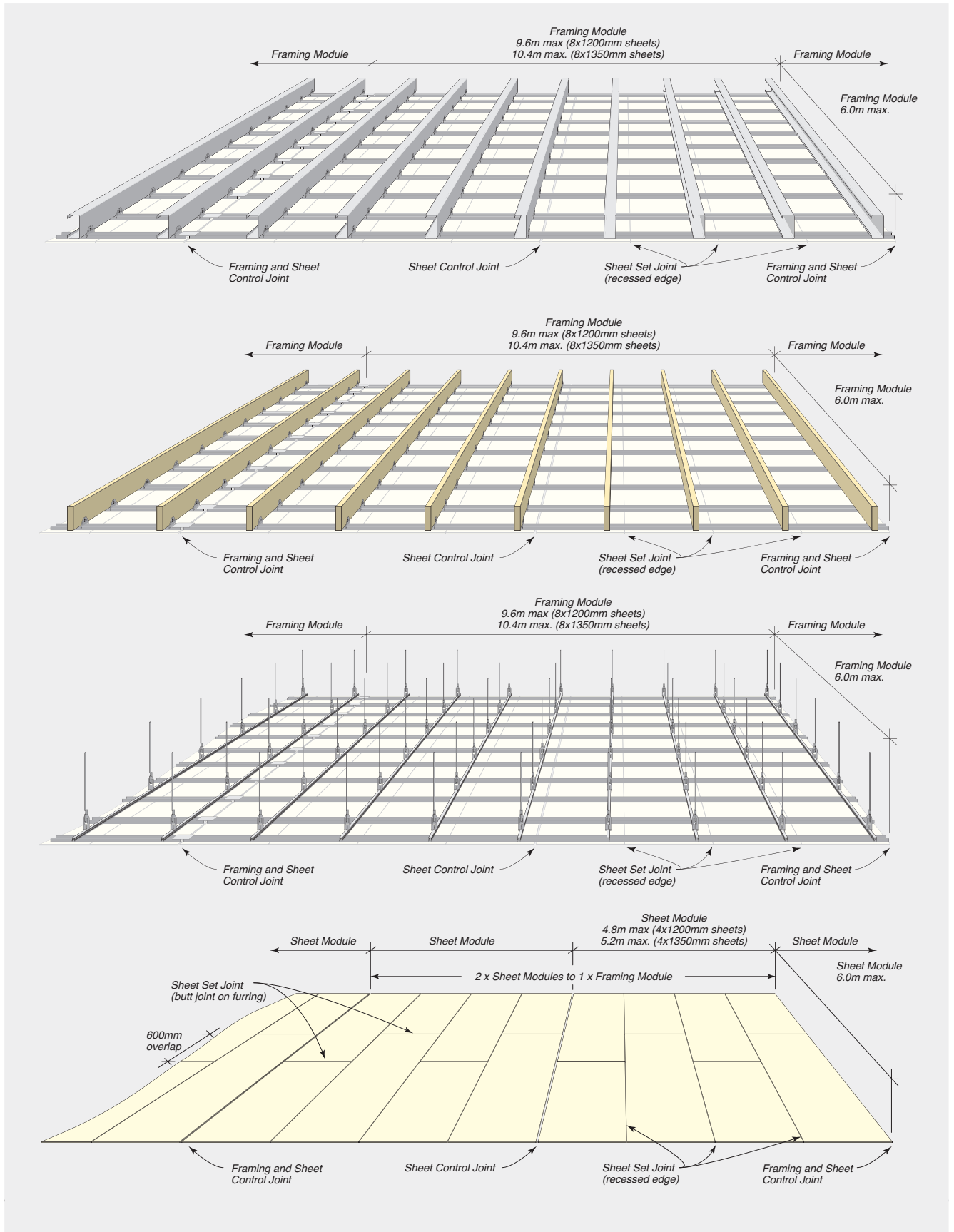

07

INSTALLATION, CONSTRUCTION DRAWINGS + DETAILS

INSTALLATION DETAILS - INTERNAL CEILING SYSTEMS WITH FLUSH-SET JOINTS

FIGURE 8.23 Perimeter Detail

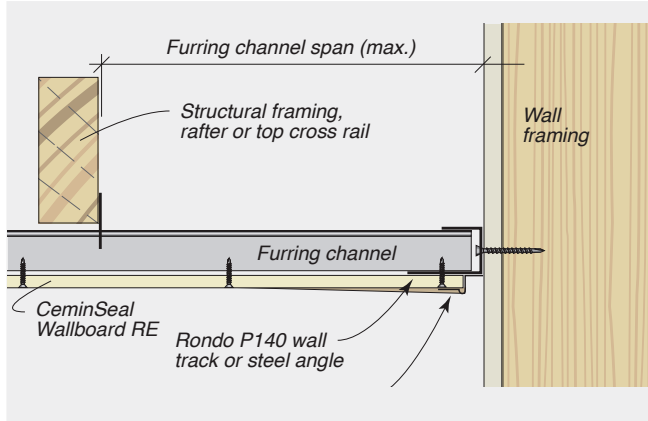

FIGURE 8.26 Perimeter Detail

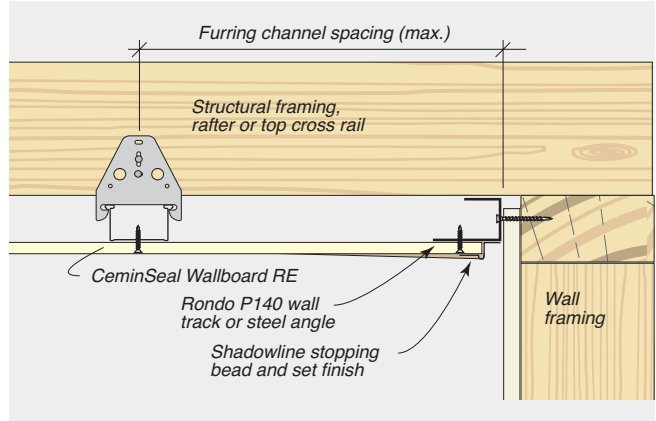

FIGURE 8.24 Perimeter Detail

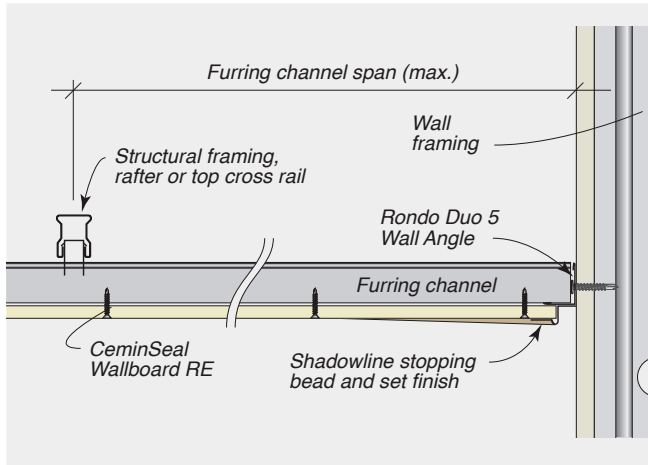

FIGURE 8.27 Perimeter Detail

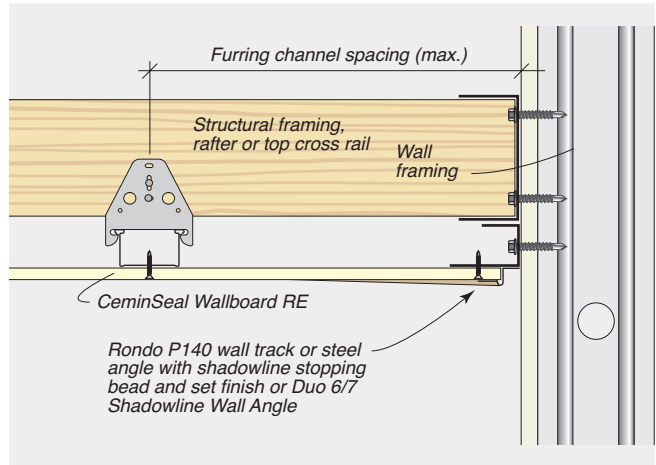

FIGURE 8.25 Framing and Sheet Module Control Joint

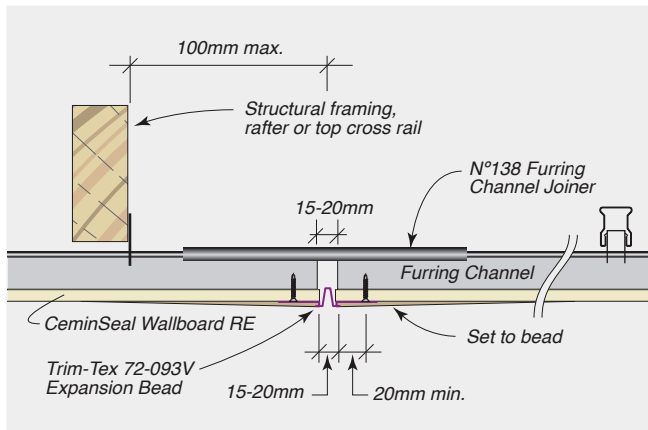
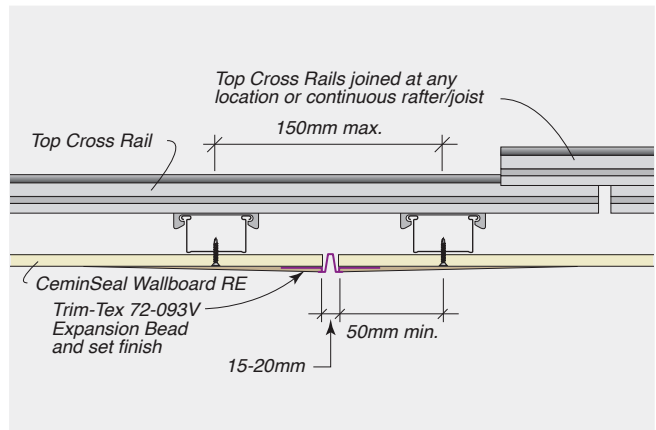

FIGURE 8.28 Framing and Sheet Module Control Joint



INSTALLATION, CONSTRUCTION DRAWINGS + DETAILS



INSTALLATION DETAILS – INTERNAL CEILING SYSTEMS WITH FLUSH-SET JOINTS

FIGURE 8.29 Sheet Module Control Joint

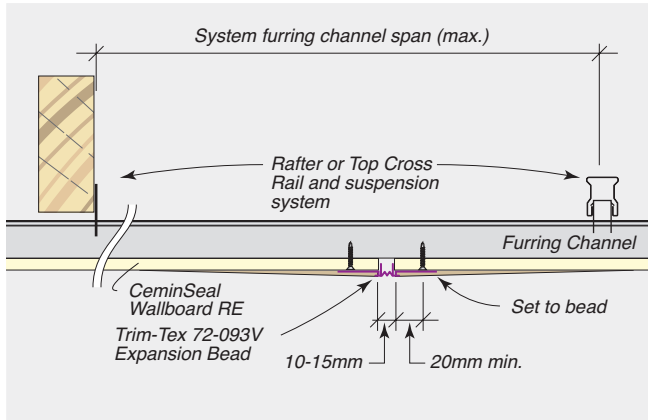

FIGURE 8.32 Sheet Set Joint (Butt or End Joint)

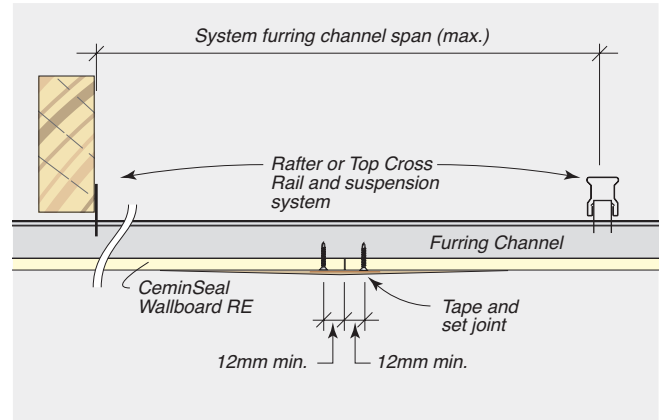

FIGURE 8.30 Flush-Set Jointing – Internal System Recessed Edge. (Refer to the JOINTING section in this guide for more detailed information)

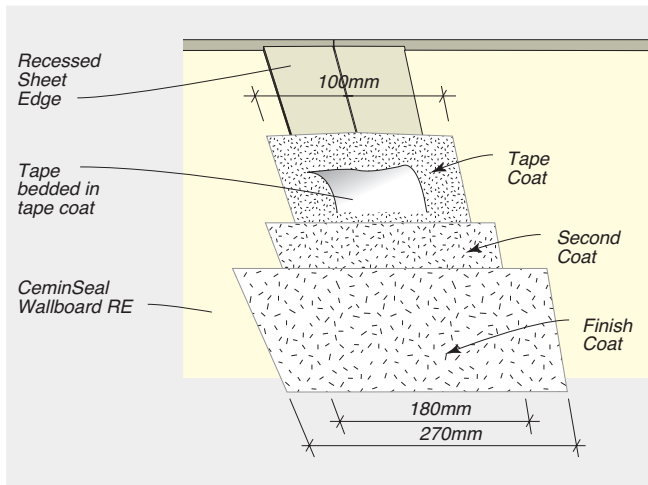

FIGURE 8.33 Flush-Set Jointing – Internal System Butt Joint. (Refer to the JOINTING section in this guide for more detailed information)

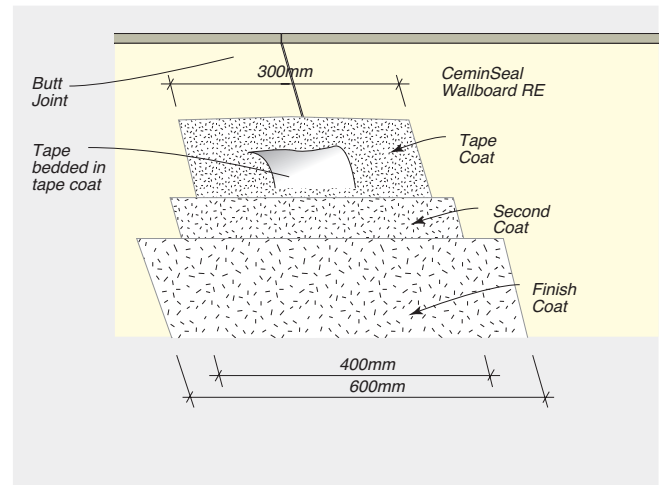
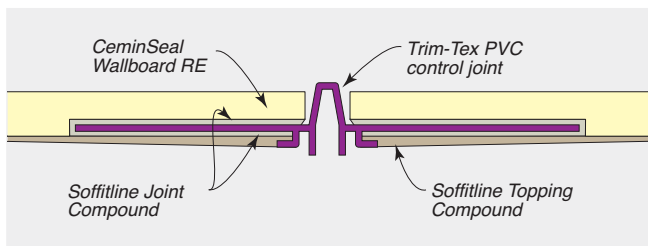

FIGURE 8.31 Control Joint Detail – Internal Application (External similar)



Please ensure TRIM-TEX 72-093V (UV stabilised) for external applications, Trim-Tex PVC control joint is not recommended for external applications



JOINTING



After Soffitline or CeminSeal Wallboard sheets have been fixed, the joints and/or fastener heads require setting to provide a smooth surface for decoration.

Internal Systems

Joints in CeminSeal Wallboard ceilings used in internal locations may be jointed using Gyprock plasterboard methods and compounds. Refer to The Red Book 02 Residential Installation Guide for complete details. When using Wet Area Base Coat, remove excess material while it is wet to reduce sanding.

Tape Coat

1. Apply tape coat to both sides of the joint, bed the tape centrally over the joint and lightly cover with compound.
2. Cover all fastener heads with tape coat.
3. Allow tape coat to set/completely dry before proceeding.

Note: A minimum 1mm compound is to be left under the tape.

Second Coat

1. Apply a second coat to width as shown. Feather the edges with a trowel.
2. Cover fastener heads with a second coat, extending beyond the first coat by about 25mm.
3. Allow the second coat to set/completely dry before proceeding.

Finish Coat

1. Apply a finish coat centrally over the second coat, to width as shown. Feather the edges with a trowel. (If required, soften the outer edges of the compound with a damp brush before feathering).
2. Cover fastener heads with a finish coat, extending beyond the second coat by about 25mm. Ensure that the edges of the compound are neatly feathered and that there are no knife edge marks left in the final stopping.

Sanding

When set/completely dry, sand compound smooth with 150/180 grit paper or cloth, or with 220 grit sanding mesh and a sanding block.

Caution: If previous coats of drying type compounds are not thoroughly dry before application of subsequent coats, imperfections can result from delayed shrinkage of the compound. Avoid any heavy pressure which might scuff the joints.

FIGURE 9.01 Flush-Set Jointing – Interior System Recessed Edge

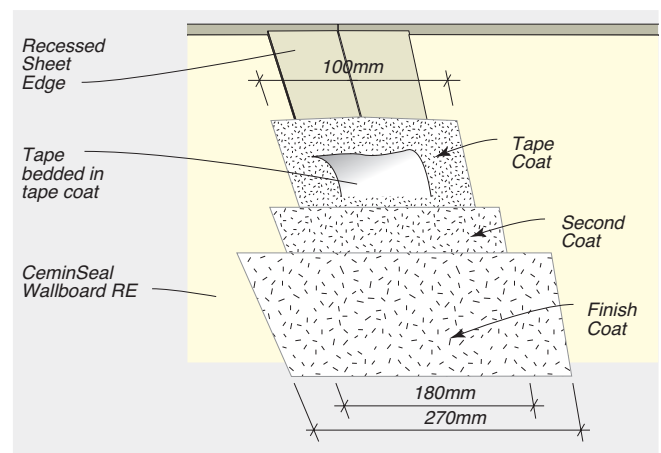

FIGURE 9.02 Flush-Set Jointing – Interior System Butt Joint

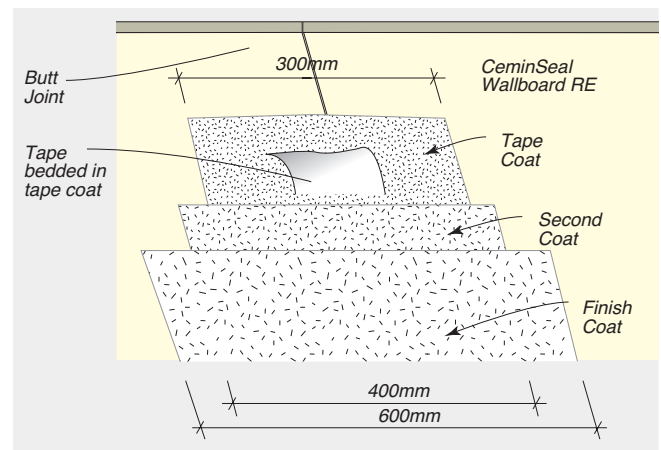

TABLE 10.01 Jointing System Selection – Internal Ceilings

Tape Coat	Second Coat	Finish Coat
Any of the following:	Any of the following: (*see note)	Any of the following:
Base Coat 20	Base Coat 20*	Jointmaster
Base Coat 45	Base Coat 45*	Ultra-Top
Base Coat 60	Base Coat 60*	Gyprock Gold
Base Coat 90	Base Coat 90*	Less Mess Multipurpose
Ultra Base MR 60	Ultra Base MR 60	Easy-Finish
Wet Area Base Coat	Wet Area Base Coat	Easy-Flow
Easy-Flow	Easy-Flow	

* Setting compound. Do not use a setting compound over a drying type compound.



JOINTING

External Systems

Recessed joints in Soffitline ceilings used in external locations must be set using Soffitline external compounds and paper tape.

Soffitline compounds are acrylic and have different sanding characteristics than plaster products, and require increased sanding effort. Care should be taken in the application of both jointing and topping compounds to minimise the use of excess material. This will result in little need for sanding.

Taping Coat

1. Fill recess evenly and fully with Soffitline External Jointing Compound. Only the recess area should be filled; avoid spreading the compound over the face of the sheet
2. Bed in the paper tape centrally over the joint and cover lightly with compound.
3. Allow to dry completely, approximately 2–4 hours in warm conditions.

Second Coat

1. If required apply a second coat of Soffitline External Jointing Compound to ensure tape is completely covered. Do not spread the compound wider than the recess. Feather edges whilst the compound is wet.
2. Allow compound to dry and harden thoroughly, approximately 2–4 hours in warm conditions.

Finish Coat

1. Scrape joint with a joint knife to remove any excess jointing compound.
2. Apply a thin coat of Soffitline Topping Compound centrally over the joint, about 270mm wide. Ensure that the edges of the compound are neatly feathered to minimise sanding.

Fasteners

Fasteners may be coated with up to three coats of Soffitline Topping compound. The fasteners must be driven just below the board surface so that a smooth finish can be achieved. Ensure that there are no knife edge marks left in the final stopping.

Sanding

With careful compound application, sanding should be minimal. When required, ensure the topping is dry, and sand smooth with 120 grit paper. Avoid any heavy pressure which might scuff the joints.

FIGURE 9.03 Flush-Set Jointing – External Soffitline System Recessed Joint

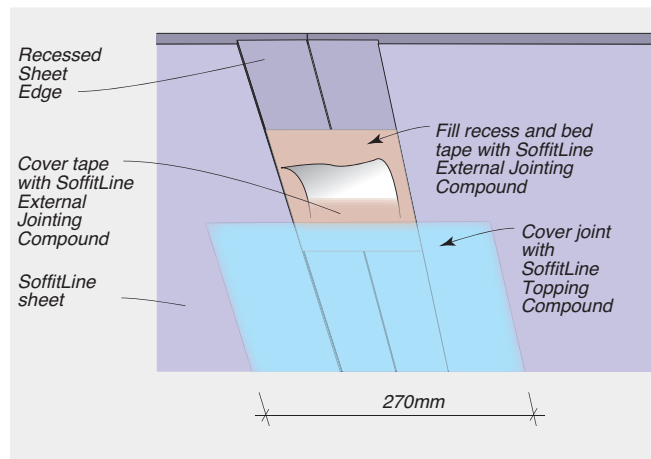

Installation Tip:

Avoid the use of excess compounds to reduce sanding requirements.

TABLE 10.02 Jointing System Selection – Exterior Ceilings

Tape Coat	Second Coat	Finish Coat
Soffitline External Jointing Compound	Soffitline External Jointing Compound	Soffitline Topping Compound



SAFETY, HANDLING, GENERAL CARE
+ WARRANTY



SAFETY, HANDLING + GENERAL CARE

Health, Safety and Personal Protection Equipment (PPE)

Fibre Cement contain silicas that are harmful if inhaled. Protective clothing and breathing equipment should be worn when cutting products. When cutting, drilling or grinding fibre cement sheets using power tools, always ensure the work area is properly ventilated.

An approved dust mask (AS/NZS 1715 and AS/NZS 1716) and safety glasses (AS/NZS 1337) must be worn. Cemintel recommends that hearing protection also be worn.

Safety Data Sheet information is available at www.cemintel.com.au

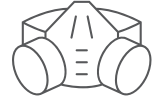

Managing Respirable Crystalline Silica Dust

Crystalline Silica is everywhere. It is found naturally in stone, rocks, sand, gravel and clay. Sand is one of the raw materials in Fibre Cement. Respirable Crystalline Silica dust is the fine dust that's created when you use power tools to cut, drill, grind, chip or sand materials and products that contain crystalline

silica. This dust is of concern due to its size as it gets caught deep in your lungs and can cause long term damage.

IF YOU USE THE CORRECT SAFETY EQUIPMENT AND PPE, FIBRE CEMENT IS SAFE TO USE.



Cemintel Safety Requirements

1 - Cut Outdoors*	The ventilation outdoors is greater than that indoors, and therefore should reduce exposure.
2 - Use On-Tool Dust Extraction	Use on-tool dust extraction when using power tools to drill and cut Fibre Cement, with a vacuum that contains a HEPA M Class filter.
3 - Correct Saw and Blade	Use a plunge saw with a specifically designed Fibre Cement blade.
4 - Don't Sweep, Vacuum instead	When completing your work vacuum with a HEPA M Class filter, rather than a broom as sweeping creates more dust.
5 - Use Correct Respirator	Use a half face P1 or P2 respirator. It is essential that the respirators are Fit Tested and workers are cleanly shaven to obtain a good seal.

* Even though not recommended, indoor cutting can be completed when using an onsite cutting room with exhaust ventilation and a M class filter at a minimum, on-tool dust extraction with a vacuum with a HEPA M Class filter, a Full Face P2 respirator and conducting local occupational and static air monitoring to validate effectiveness of control measures.

Safety, Handling, and Maintenance

Storage

All Cemintel sheets must be stacked flat, clear of the ground and supported at 300mm maximum centres on a level platform. Sheets must be kept dry, preferably stored inside the building. Sheets must be dry prior to fixing, hence if it is necessary to store outside, the product must be protected from the weather.

Handling

Cemintel sheets must be treated with care during handling so as to avoid damage to edges. Sheets should be carried horizontally on edge by two people.

Cutting

Sheets should be fully supported and cut from the back using a power saw. Cemintel recommends using the Makita Plunge

Cut Saw with guide rail and appropriate blade, together with the appropriate dust extraction system. All exposed cut edges **MUST BE SEALED WITH CEMINTEL EDGE SEALER TO PREVENT MOISTURE ABSORPTION.**

Mitres

It is not recommended to mitre sheet edges as this can cause delamination of the face.

Penetrations

Penetrations in sheets may be cut or drilled prior to installation. Cut from the back or drill from the front.

Cut penetrations oversize by 8-10mm all around. Mask, prime and fill gaps with sealant in accordance with recommended methods and products.

Warranty

Both Cemintel Soffitline and CeminSeal Wallboard RE/SE sheets have a product warranty of 25 years.

The full product warranty is available for download at cemintel.com.au

NOTES

A large grid of small dots for taking notes, covering the majority of the page below the 'NOTES' header.



Our Offices

Sydney

376 Victoria Street
Wetherill Park NSW 2164

Adelaide

Lot 100 Sharp Court
Mawson Lakes SA 5095

Darwin

Cnr Stuart Highway
& Angliss Street
Berrimah NT 0828

Melbourne

277 Whitehall Street
Yarraville VIC 3013

Perth

19 Sheffield Road
Welshpool WA 6106

Brisbane

768 Boundary Road
Coopers Plains QLD 4108

Hobart

11 Farley Street
Derwent Park TAS 7009

cemintel.com.au

1300 236 468

For Design and Technical Support:

DesignLINK – 1800 621 117

Cemintel is a trading entity of CSR Building Products Limited (ACN 008 631 356).

The products referred to in this document have been manufactured by or on behalf of CSR Building Products Limited ("CSR") to comply with the National Construction Code of Australia (NCC) and any relevant Australian Standards. While any design or usage guidelines set out in this document have been prepared in good faith by CSR, they are of a general nature only and are intended to be used in conjunction with project specific design and engineering advice.

It is the responsibility of the customer to ensure that CSR's products are suitable for their chosen application, including in respect of project-specific matters such as, but not limited to structural adequacy, acoustic, fire resistance/combustibility, thermal, and weatherproofing requirements. All information relating to design/installation/application of these products is offered without warranty and no responsibility can be accepted by CSR for errors and omissions, or for any use of the relevant products not in accordance with CSR's technical literature or any other relevant industry standards. For current technical and warranty documentation relating to Cemintel's products, visit Cemintel's website at www.cemintel.com.au.

05/2026