



TABLE OF CONTENTS

01 INTRODUCTION	2	Fire Performance	21
Introduction	2	Extreme Climate Conditions	21
02 PRODUCT OVERVIEW	3	Corrosivity Categories	22
Panel Information	4	Other Design Considerations	22
Product Specifications	4	Wash Down Process	23
03 SYSTEM OVERVIEW	5	Inspection, Repair and Maintenance	23
Pressure Equalised Ventilated Cavity System	6	05 COMPONENTS + ACCESSORIES	24
Sealant Filled Joints	7	06 SYSTEM ENGINEERING	28
Applications	8	Design, Detailing and Performance	
Benefits of the Cemintel's Commercial ExpressPanel with the ExpressWall Fixing System	8	Responsibilities	29
System Solutions	8	Spacing of Horizontal H515 Top Hats	31
04 DESIGN + AESTHETIC CONSIDERATIONS	9	ExpressWall and Intermediate Top Hat Spacings	32
General	10	Panel Fixing Requirements	33
Panel Appearance & Finish	10	07 INSTALLATION	35
Panel Layout	11	Checklist – Prior to Installation	36
Structural	11	Installation Set-Out	37
Top Hats	13	Installation for Timber and Steel Framing	37
Pre-Drilling Panel Holes	13	Installation of Cemintel Rigid Air Barrier™	43
Face Fixings	13	Installation of Soft Air Barriers	45
Window & Door Openings	14	08 CONSTRUCTION DRAWINGS + DETAILS	47
Eaves Junction	14	09 SAFETY, HANDLING, GENERAL CARE + WARRANTY	65
Control Joints	14	Health, Safety and PPE	66
Moisture Management	15	Safety, Handling & Maintenance	66
Energy Efficiency & Thermal Design	18	Warranty	66
Climate Zones for Thermal Design	20		

Introduction

Cemintel's Commercial ExpressPanel® with Commercial ExpressWall® system combines a pre-primed panel with a simple installation system to create the Cemintel Commercial ExpressPanel® wall systems that can be used for residential and commercial buildings.

This Design and Installation Guide recommends good building practice methodology and has been prepared as a general guide of design considerations, system engineering information and installation procedures for common external applications. It assumes that the user has an

intermediate knowledge level of building design and construction. In no way does it replace the services of the building professionals required to design projects, nor is it an exhaustive guide of all possible scenarios. It is the responsibility of the architect, designer and various engineering parties to ensure that the details in this Design and Installation Guide are appropriate for the intended application.

Commercial ExpressPanel can be installed in either horizontal or vertical orientations, and in external or internal applications.

A large, stylized graphic of the number '022' in a light gray, outlined font, positioned in the lower half of the page. The '0' is a simple oval, the first '2' has a curved top, and the second '2' is more angular.

PRODUCT OVERVIEW

Panel Information

Cemintel Commercial ExpressPanel sheets are pre-primed, square edged, compressed fibre cement (CFC) panels, manufactured to AS/NZS 2908.2.

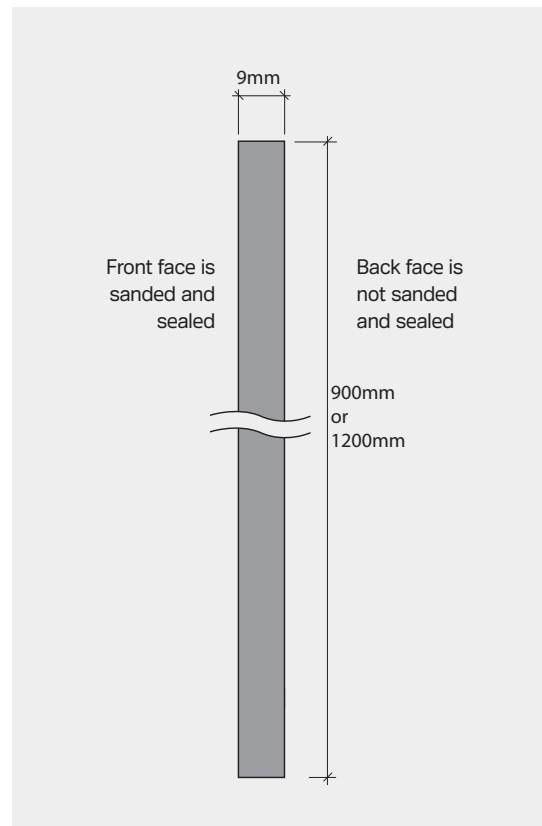
Consisting primarily of Portland Cement, cellulose fibre, air and water, panels are compressed to produce a dense 9mm panel that offers superior performance in terms of strength and durability, making Commercial ExpressPanel an excellent choice for commercial applications subject to higher wind loads.

Panels are factory sealed on both faces and all edges for increased weather resistance and durability.

Commercial ExpressPanel sheets are ready for painting and can be either factory painted or finished onsite with painted finishes (as per manufacturer's specifications).

Commercial ExpressPanel is popular with architects and designers with its pre-primed face that can be finished with a wide range of treatments.

Commercial ExpressPanel cladding conforms to the requirements of AS/NZS 2908.2 – Cellulose-cement products, Part: 2 – Flat sheets, Category 5, Type A.

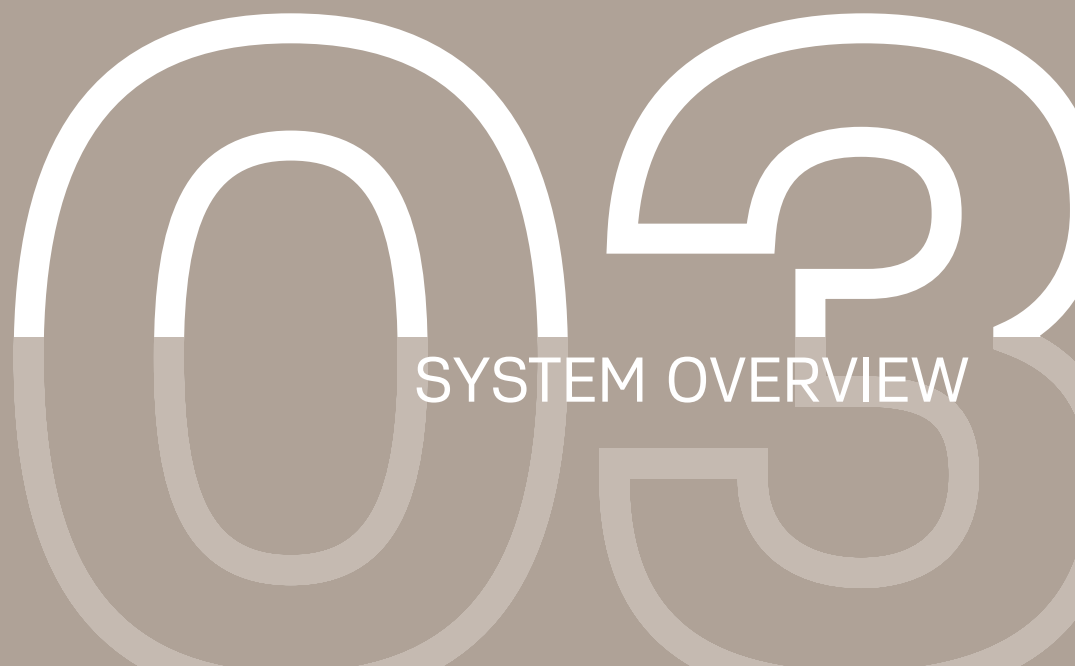


Product Specifications

Property	Specification	Manufacturing Tolerance	Relevant Standard
Panel Width	900 and 1200mm	+ 0.0mm / - 2.0mm	AS/NZS 2908.2
Panel Length	1800,2100,2400,2700 and 3000mm	+ 0.0mm / - 2.0mm	AS/NZS 2908.2
Panel Thickness	9mm	+ 0.9mm / - 0.0mm	AS/NZS 2908.2
Panel Weight (EMC)	17.8kg/m ²	NA	AS/NZS 2908.2

EMC – Equilibrium Moisture Content

Product Code	Thickness (mm)	Width (mm)	Length (mm)	Mass (Nominal)	Panels per pack
25681	9	900	1800	17.8kg/m ²	20
25682	9	900	2400	17.8kg/m ²	20
25683	9	900	3000	17.8kg/m ²	20
25676	9	1200	1800	17.8kg/m ²	20
25677	9	1200	2100	17.8kg/m ²	20
25678	9	1200	2400	17.8kg/m ²	20
25679	9	1200	2700	17.8kg/m ²	20
25680	9	1200	3000	17.8kg/m ²	20

A large, stylized graphic of the numbers '03' in a light beige color, serving as a background for the title. The '0' is a simple oval, and the '3' has a curved top and a vertical stem.

SYSTEM OVERVIEW

03

SYSTEM OVERVIEW

Pressure Equalised Ventilated Cavity System

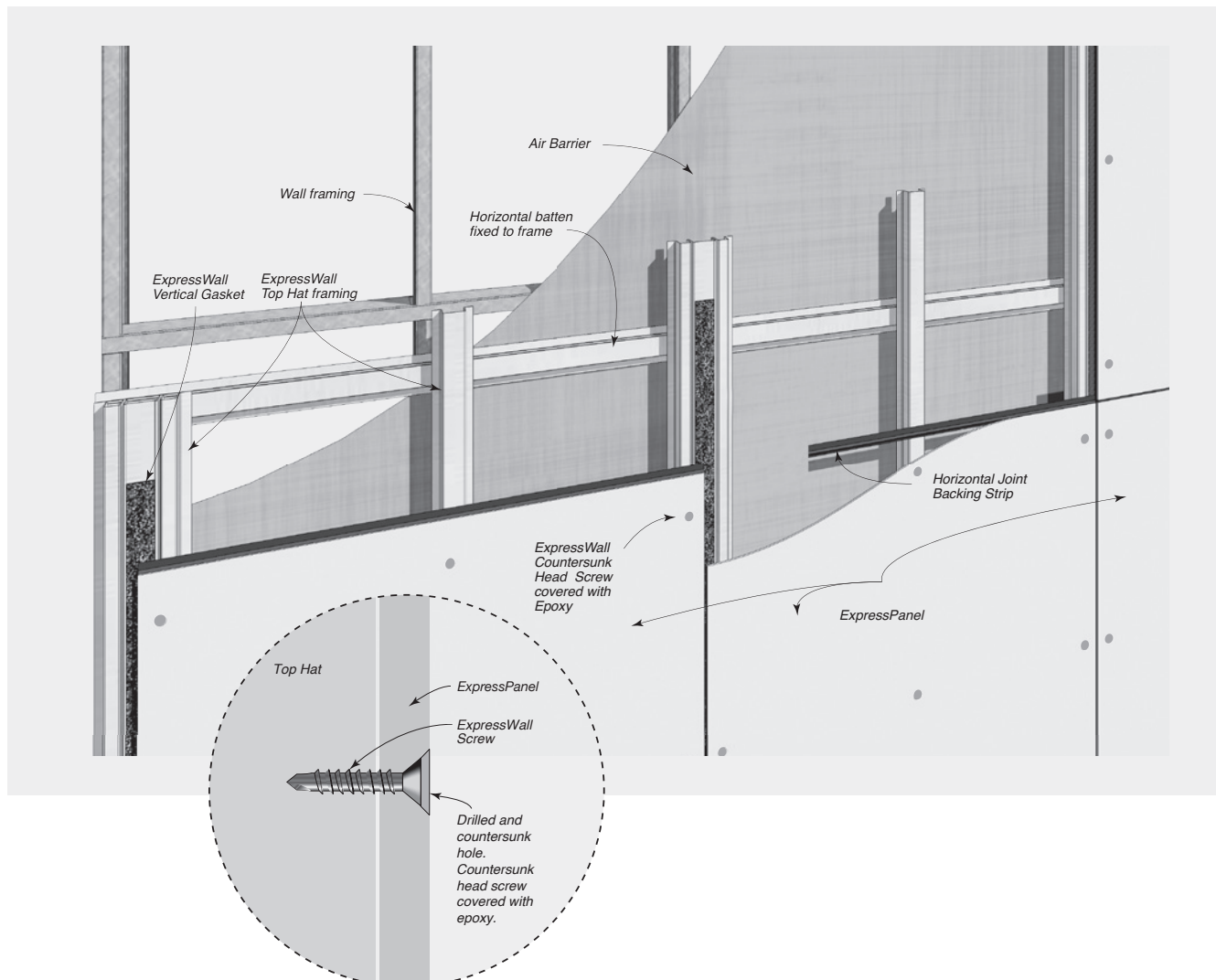
Cemintel Commercial ExpressPanel can be installed horizontally or vertically onto steel or timber stud framing or masonry/concrete using the proven and versatile ExpressWall® Top Hat Framing System. The ExpressWall system provides a versatile and durable façade which is suitable for an extensive range of building types. Panels are pre-drilled and then fixed with expressed joints to vertical metal top hats using countersunk head screws. A vertical gasket tape is placed on the top hat to provide added weather resistance, and a backing strip is used at horizontal joints to reduce water ingress.

Panels are installed as a pressure equalised ventilated cavity system which is easy to install and delivers a high weather performance system. In certain conditions, eg. higher corrosive zones, there is the option of sealing joints and header to reduce the circulation of air behind the façade.

This manual provides information on both systems.

Pressure Equalised Ventilated Cavity System

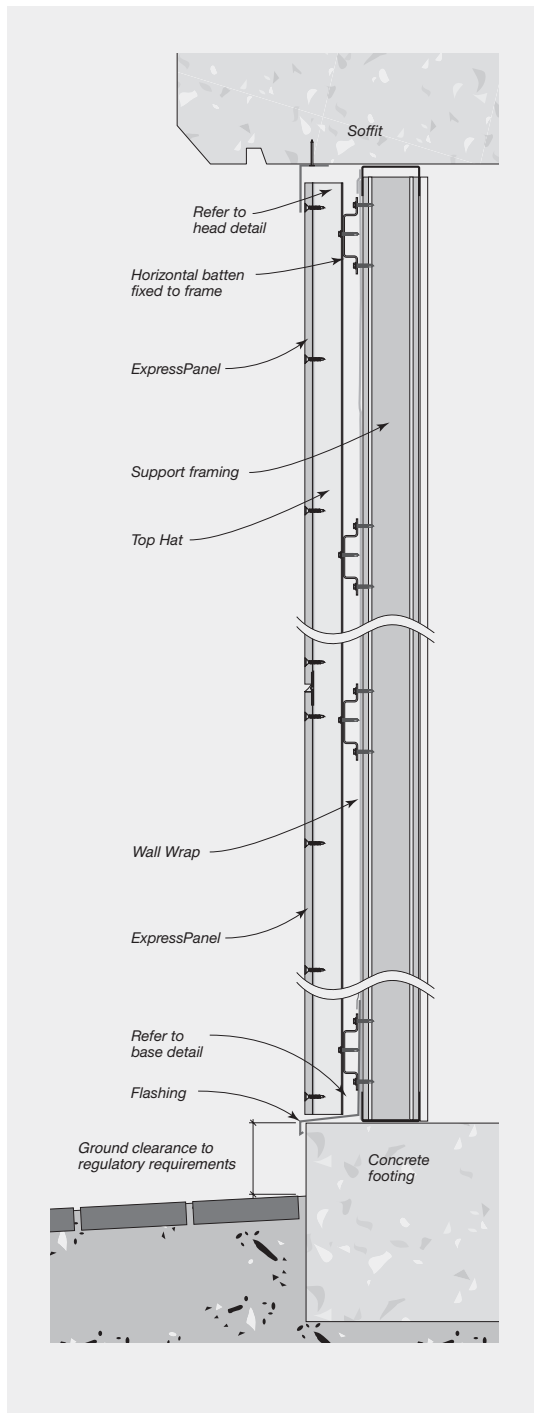
Cemintel Commercial ExpressPanel is installed over an air barrier onto ExpressWall™ top hats using Hex Head or Countersunk Head Screws. This creates a pressure equalised cavity system which enhances weather resistance.



SYSTEM OVERVIEW



Typical Commercial ExpressPanel Wall System Cross Section for Steel Framing



In a pressure equalised system, a cavity is formed between an air barrier, cavity baffles at major corners and the panels. Openings around the base and top of the façade allow pressure equalisation, and create the drying benefits of air circulation and drainage. Cavity baffles limit the airflow between the cavities either side of a major corner. This system reduces the risk of moisture penetration and prevents moisture build up, allowing the building shell to dry out, creating a healthier, more breathable building.

Panels are installed to give an express jointed appearance. A vertical gasket tape is placed on the vertical top hat and a metal backing strip is placed at horizontal joints. Horizontal joints at base of wall and at inter-storey junctions are left open to maintain a ventilated cavity and to allow for moisture drainage.

The air barrier may consist of a wall wrap or rigid materials such as fibre cement, metal sheet, or masonry. The installation of Bradford Enviroseal™ CW-IT wall wrap and Cemintel Rigid Air Barrier as air barriers are detailed in this guide and the Cemintel Rigid Air Barrier Design and Installation Guide. Other wall wraps and sheet materials must be installed in accordance with manufacturer's instructions.

Masonry and concrete substrates must be sealed to act as an air barrier for an effective waterproofing system.

Sealant Filled Joints

In some applications it may be preferable to install Commercial ExpressPanels with joints that are sealant filled. In this case, horizontal backing strips are used and joints are sealed to minimise moisture getting into the cavity. Sealant is also applied to the underside of slabs.

Cemintel Commercial ExpressPanel shall be pre-drilled and then fixed onto supporting metal top hats using countersunk head screws.

03

SYSTEM OVERVIEW



Applications

Cemintel Commercial ExpressPanel is suitable for all building classes where metal top hats can be fixed to framing however, site environmental factors such as wind and corrosivity zones must be taken into account to determine its suitability for a particular application.

The panels and system have been designed to withstand ultimate wind pressures up to 7.0 kPa including cyclonic conditions.

Benefits of Cemintel Commercial ExpressPanel with the ExpressWall Fixing System



- Fire – fibre cement sheets can be used where non-combustible material is required under the NCC provisions.
- Systems are available for thermal, acoustic and fire requirements as part of an overall solution for Australian conditions.
- Suitable for a wide range of finishes.
- Large format, lightweight panels are designed to be fixed to top hats which can be fixed to industry standard steel, timber or masonry structural frames.
- Cemintel's express jointed fixing system is tested and widely recognised for its high performance.
- ExpressWall top hat has a wider fixing surface for increased installation tolerance, allowing panel movement with changes in wind pressures, thermal movement etc.
- Cemintel's pressure equalised ventilated cavity system allows for higher wind loads, minimises water ingress and allows air flow and drainage.
- The countersunk head screws are covered and filled with epoxy compound for a flush finish on the panel face.
- Suitable for Bushfire Attack Level up to 40 (BAL-40) when constructed in accordance with AS 3959.
- Panels are easy to cut using standard fibre cement cutting equipment e.g., around windows and power boxes.
- Termite resistant.
- Durable and weather resistant:
 - Provides effective protection against wind, rain and temperature extremes, mould and mildew.
 - Panels will not rot, swell or warp when correctly installed and maintained.

System Solutions

A technical Data Sheet can be downloaded from cemintel.com.au

Fire Resistance Level (FRL)	Up to 120/120/120, -/180/180 when used in a system with Gyprock fire grade plasterboard	Refer to Gyprock The Red Book
Bushfire Construction	BAL-40 (Construction for Bushfire Attack Level 40 for an external wall)	AS 3959
Weatherproofing	Suitable for serviceability wind pressures of +2.5kPa with Cemintel Rigid Air Barrier and +1.19kPa with Enviroseal CW-IT wall wrap, when installed as a pressure equalised system.	AS/NZS 4284
Wind actions (including Cyclonic)	Suitable for ultimate wind loads up to 7.0 kPa with Cemintel Rigid Air Barrier, including cyclonic conditions, and up to 2.5 kPa with Enviroseal CW-IT	AS/NZS 4284 & AS 4040.3

A large, stylized number '04' is rendered in white with a thick outline. The '0' is a simple oval shape, and the '4' is composed of a vertical line on the left, a diagonal line from the top-left to the bottom-right, and a horizontal line at the bottom. The number is positioned in the lower right quadrant of the page, with the text 'DESIGN + AESTHETIC CONSIDERATIONS' overlaid on it.

DESIGN + AESTHETIC
CONSIDERATIONS

04

DESIGN + AESTHETIC CONSIDERATIONS

This section outlines some important areas for consideration in determining whether Cemintel Commercial ExpressPanel System is suitable for the required application. The following points are not exhaustive. It is the responsibility of the Architect / Building Designer to ensure the design conforms to NCC requirements and other relevant building standards that may exist for that location. This guide should be read in conjunction with the NCC.

Panels, top hats and structural framing are required to resist wind loads that are specific to the building site. Additional “local pressure factors” apply to the panels and top hats in accordance with the wind code AS/NZS 1170.2.

Once wind loads have been determined top hat spans, fastener spacings, and sheet fixing details can be selected from the appropriate tables in the ‘System Engineering’ Section of this guide. It is also the responsibility of the Architect/Building Designer to select the appropriate corrosivity category.

Panel Appearance and Finish

Commercial ExpressPanel is factory sealed on both faces and all edges. Sealing in this manner increases the durability and stability of the panels. The exterior surface of ExpressPanel must be coated with an appropriate finish. Note that the back face of panels cannot be painted, and are not suitable as an exterior finish.

Where panels are cut onsite, sealing of the cut edges shall be Dulux Acra-Prime 501/1, also known as AcraPrime WB. The minimum application rate shall be 1 litre per 10m² (140 grams/m²) which results in a dry film thickness of 70 microns. Alternatively, coat with undiluted Bondcrete before applying the finish coating.

The exterior face of ExpressPanel can be finished with a wide variety of coatings, provided they are compatible with the ExpressPanel seal coat, and with the epoxy used to cover the countersunk head screws. High build, exterior grade acrylic paint or aggregate finishes provide the best results. Exposed vertical gaskets should not be painted and Sikaflex Pro sealant may be painted if required.

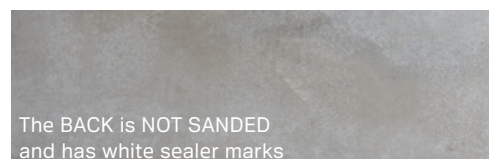
Commercial ExpressPanel may be painted off-site when exposed head screws are used. Refer to appropriate painting contractors for details and colours. For pre-painted panels, it is a requirement that all expressed joints are filled with sealant - refer to the Barestone External Design and Installation Guide – Installation Section.

A minimum dry film thickness of 250 microns is recommended to ensure adequate cover for the concealed fasteners.

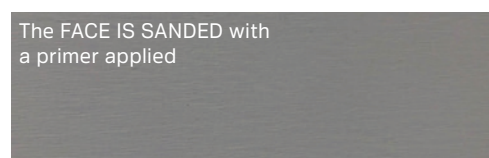
High gloss and low build finishes will require additional surface preparation to minimise fastener show through. In all cases the coating manufacturer’s application instructions must be followed. The inside face of the ExpressPanel is finished clear and is not suitable for painting.

Before applying finishes, all panels must be thoroughly washed with fresh water to remove any salt residue. Refer to coating manufacturer for additional requirements.

The face of panels have been sanded and have a single coat of primer applied, whereas the back of the panel is smooth with white sealer marks. If you are unclear on the distinction, please contact Cemintel prior to installation.



The BACK is NOT SANDED and has white sealer marks



The FACE IS SANDED with a primer applied

DESIGN + AESTHETIC CONSIDERATIONS



Panel Layout

Panel layout should take into account the following:

- Aesthetic design.
- Top hat spacing to allow for expressed joint widths (Refer Fig. 4.01).
- 8-10mm recommended joint width.
- Type of structural support.
- Size and location of openings.
- Building size.
- Location of building control joints.

Panel layout can be in a grid pattern where vertical and horizontal joints are continuous (Refer Fig. 4.02 & Fig. 4.03). In these layouts, construction joints may be positioned behind any vertical or horizontal sheet joint (refer to “Construction Drawings & Details” section).

Panel layout can also be in a vertical or horizontal half-bond pattern where some joints are discontinuous (Refer Fig. 4.04 & Fig. 4.05).

This is not an exhaustive list of panel layouts.

FIGURE 4.01 Typical Top Hat set-out - 1200mm Width Vertical Panels with 10mm Joints shown

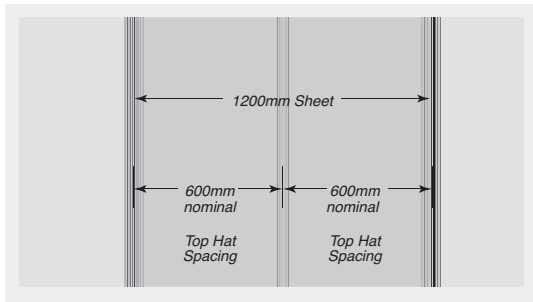


FIGURE 4.02 Horizontal Sheeting Aligned Grid Pattern

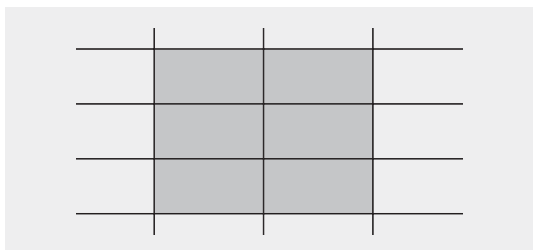


FIGURE 4.03 Vertical Sheeting Aligned Grid Pattern

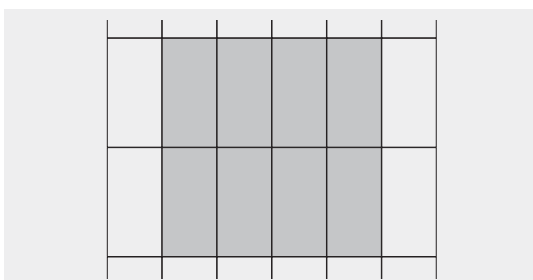


FIGURE 4.04 Horizontal Sheeting Half-bond Pattern

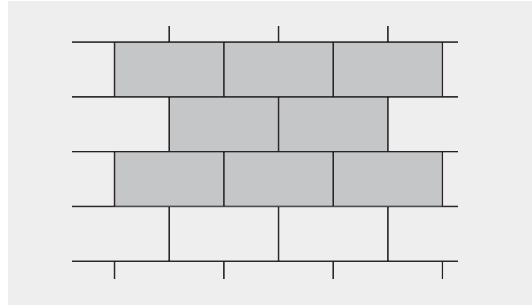


FIGURE 4.05 Vertical Sheeting Half-bond Pattern

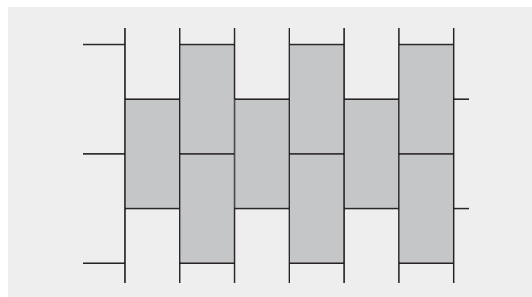
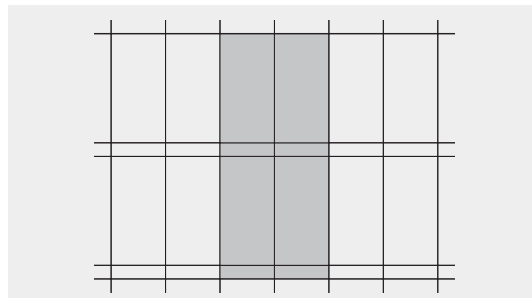


FIGURE 4.06 Skirt Panel (Floor to Floor in Excess of 3m)



Structural

Framing and Substrate Options

Commercial ExpressPanel and ExpressWall system can be fixed to either timber or steel framing, as well as to masonry and concrete substrates.

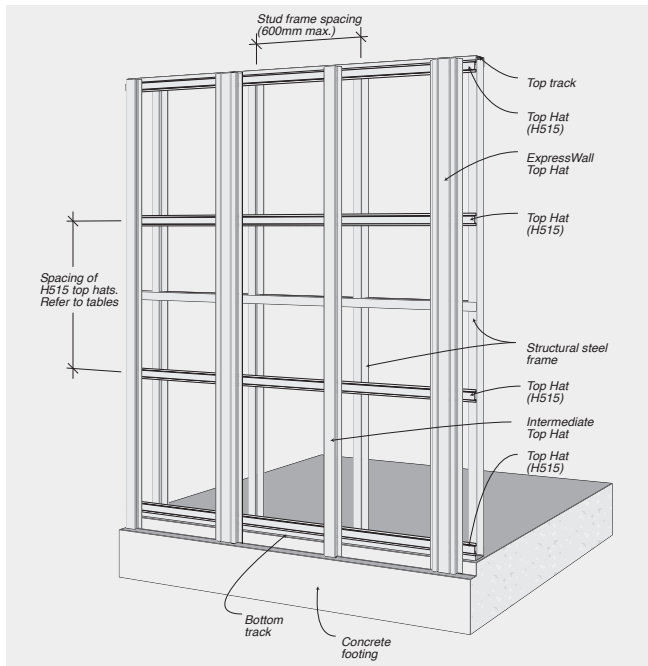
For timber and steel framing, the minimum requirement shall be in accordance with the following standards:

- AS 1720 – Timber Structures.
- AS 1684 – Residential Timber-Framed Construction.
- AS/NZS 4600 – Cold-Formed Steel Structures.
- AS 3623 – Domestic Metal Framing.

Timber Stud or Steel Framing

Cemintel ExpressWall Top Hats and Intermediate Top Hats must be installed vertically onto horizontal H515 top hats and supported by a primary structural system (ie timber or steel stud framing – Refer Fig. 4.07).

FIGURE 4.07 Fixing to Timber or Steel Stud Framing



Alternatively ExpressWall framing can be fixed to appropriately designed steel or timber framing. The frame must be designed to support the top hats at the top and bottom of the wall and at cross members within the span of the wall (Refer Fig 4.08).

The connection of Top Hats to the structural frame requires engineering design. It is the responsibility of the project engineer to specify the connection of the top hats to the support structure.

It is critical that the frame is true and plumb. Industry best practice for framed tolerance allows up to 5mm misalignment over a 3m distance.

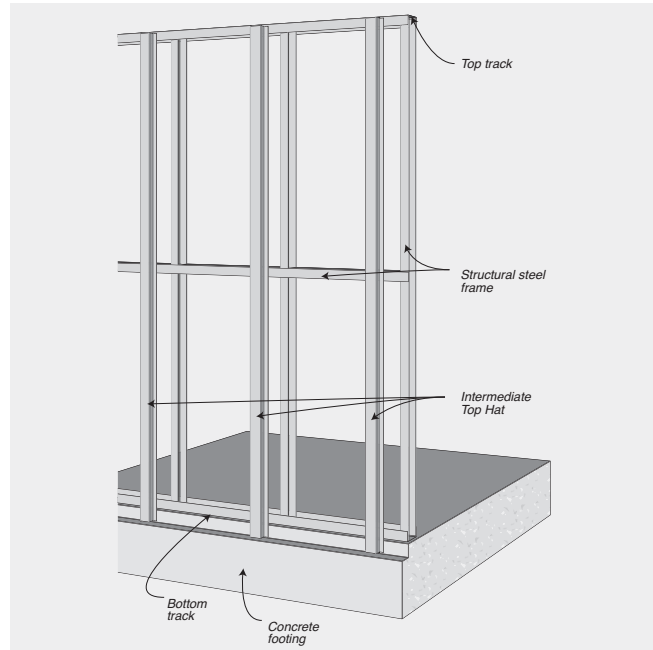
When retrofitting Commercial ExpressPanel to existing walls, the suitability of the substrate must be assessed.

AS/NZS 1170.0 Table C1 suggests that support framing be designed for a maximum deflection of span/250.

Span tables are located in 'System Engineering' section.

In highly corrosive environments, appropriate measures should be taken to protect the frame and metal components from corrosion. Refer to Corrosive Zones table in 'System Engineering' section.

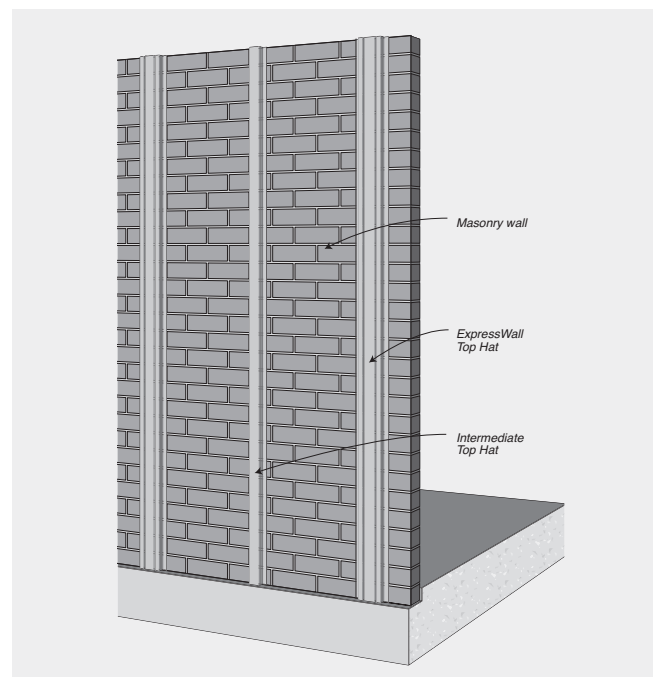
FIGURE 4.08 Fixing to Steel or Timber Framing



Masonry or Concrete Walls

ExpressWall framing can also be fixed over masonry or concrete walls (Refer Fig. 4.09). All top hat connections must be designed by the project engineer.

FIGURE 4.09 Fixing to Masonry Wall



DESIGN + AESTHETIC CONSIDERATIONS



Wind Pressures

Commercial ExpressPanel installation has been evaluated for use in all Australian wind zones up to and including N6 and Cyclonic C4 in accordance with AS 4055 for wind pressures up to 7.0 kPa under AS 1170.2 including cyclonic zones when fixed to steel framing. Fibre cement is not resistant to the projectile penetration specified in AS/NZS 1170.2.

Cavity Baffle

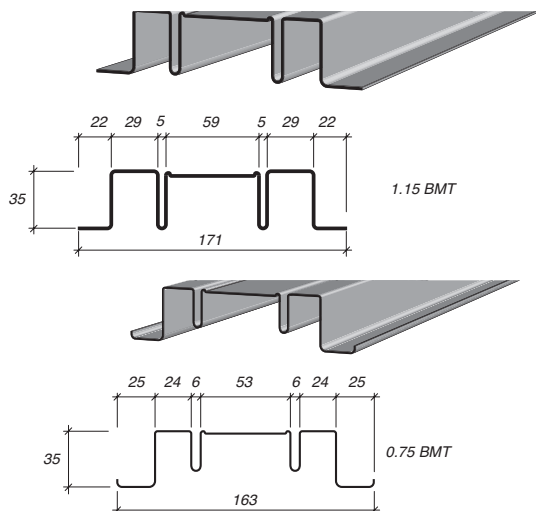
Used vertically at the major corners or other areas of the building where differential cavity pressures either side of the corner can occur. The baffle provides an obstruction to limit the airflow between cavities and promote pressure equilisation in each wall cavity section.

A cavity baffle solution can consist of a top hat section, Z-flashing, angle, channel, a backing rod and sealant, and/or self-adhesive expanding foam tape, that will bridge and close the cavity width or gaps between the corner sub-framing and air barrier layer. The baffle shall be suitable for the project design differential pressures. As required, use compatible sealants to close off any gaps between the baffle section and the air barrier layer, cladding and sub-framing.

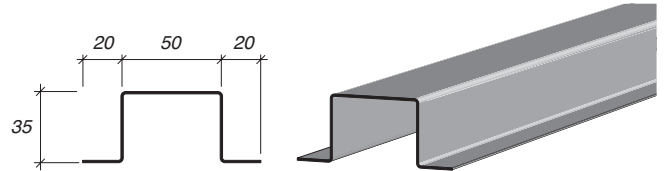
Top Hats

The Cemintel ExpressWall Top Hat Framing System consists of the ExpressWall Top and Intermediate Top Hat sections of the same thickness, of either 0.75mm BMT or 1.15mm BMT.

Cemintel's ExpressWall Top Hat is a purpose designed rolled steel section for supporting the vertical edges of the panels. The unique profile acts to accommodate movement of the sheets at the vertical joints. It is designed to be used in conjunction with the ExpressWall vertical gasket for added weather resistance. The ExpressWall Top Hat is manufactured from galvanised steel (Z275) and is the subject of Patent No 2004240142. It is available in 1.15 BMT or 0.75 BMT.

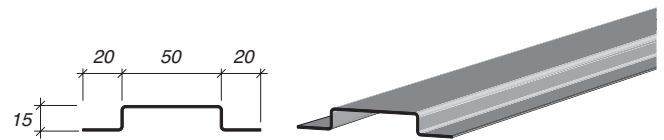


Intermediate Top Hat is used to support the panels at intermediate locations in between ExpressWall top hats. The Intermediate top hat is a rolled steel section which is manufactured from galvanised steel (Z275) of 0.75mm BMT and 1.15mm BMT.



H515 Top Hat is installed horizontally to the face of steel or timber stud framing to support the ExpressWall Top Hats and Intermediate Top Hats.

Top Hat H515 is a Rondo rolled steel section which is manufactured from galvanised steel (Z275) of 1.15mm BMT.



Pre-Drilling Panel Holes

Holes for screws must be pre-drilled. This activity can be done off-site prior to installation. Use the recommended counter sinking tool for countersunk head screws and a 6.0 – 6.5mm masonry or ceramic drill bit for pre-drilling.

Dust must be cleaned out of holes.

Face Fixings

Panels may be pre-drilled and painted off-site and fixed to top hats using exposed head screws.

Refer to the Barestone External Design and Installation Guide – Installation section, for screw fixing details.

For pre-painted panels, it is a requirement that all expressed joints are filled with sealant.



DESIGN + AESTHETIC CONSIDERATIONS

Window & Door Openings

Cemintel Commercial ExpressPanel is compatible with industry standard aluminium windows. Aluminium windows MUST NOT have sill drain holes that can direct water into the wall cavity.

With the cavity created by the top hat system, particular attention needs to be given to the set out of windows and doors.

The depth of the window needs to be taken into account in the design of the building frame so that the front face of the panel is properly aligned with the window and that the flashing is installed correctly.

If using a rigid air barrier or other sheeting, the thickness of this also needs to be accounted for to achieve a flush finish when determining window set out and reveal depths.

Cemintel recommends installing a sub frame with all windows. Refer to typical window detail drawing in 'Construction Drawings and Details' section of this guide.

Eaves Junction

Air is circulated to the wall cavity. It is not recommended that air be vented into the roof space.

Control Joints

Movement Control Joints

Control joints provided in the panel layout should be aligned with movement control joints provided in the framing.

When undertaking building additions, a movement control joint must be installed at the junction of the existing framing and the new framing. Cladding systems must be discontinuous at this joint (refer to the "Construction Drawings and Details" section).

When setting out panels, design consideration should be given to the location of joints to ensure that minimum panel lengths are observed.

Horizontal Control Joints

A horizontal control joint is required beneath every floor junction to accommodate any expected deflection. The magnitude of the deflection must be verified by the project engineer (refer to the "Construction Drawings and Details" section).

Vertical Control Joints

Vertical control joints to allow for differential movement are required at the supports of fascia trusses and at the junction of structural elements of different stiffness, such as between concrete columns and stud frames (refer to the "Construction Drawings and Details" section).

A control joint must also be installed when a masonry wall adjoins framed construction, and at the junction of framed additions or existing buildings, to allow for differential movement. Refer to 'Construction Drawings and Details' section.

Vertical joints in panels must be aligned and extend for the full height of continuous panelling, although additional joints may be placed over openings for ease of installation. As the joints are expressed, consideration to the positioning of joints is important for aesthetic reasons. Placing joints at sides or above openings, or the use of full height windows can reduce the visual impact of joints.

ExpressWall Top Hats in both 1.15mm BMT ('1.15BMT') and 0.75mm BMT ('0.75BMT') steel have been designed to elastically deform when pressure is applied during panel fixing. They have a recessed area to accept a vertical gasket tape which is made from closed cell foam with good weathering and UV resistance. It has a low compression set and low water permeability.

Structural Bracing

Cemintel Commercial ExpressPanel sheets are indirectly attached to the structural framing by way of metal top hats. As a consequence, they are not designed to provide wall bracing.

If required, bracing must be provided in the structural framing with methods such as sheet or strap bracing. Where sheet bracing is used, the entire wall framing to be clad with Commercial ExpressPanel must be sheeted to maintain a uniform fixing plane.

Note: window setout will be affected.

Termite Management

There is a wide variety of methods for managing termite entry to buildings, and selecting the appropriate method for any structure depends on specific risk factors and the form of construction.

Refer to your local pest management service, the BCA, AS 3660: Termite Management, and your local building authorities for more information about the requirements for the design of a suitable termite management system.

DESIGN + AESTHETIC CONSIDERATIONS



Moisture Management

To ensure occupant health, safety and comfort and to protect the building's water sensitive materials from damage, a condensation management strategy with the following objectives is required:

- Prevent external weather entering the building;
- Mitigate the risks associated with the accumulation of internal moisture in a building; and
- Provide construction systems that have a drainage and drying potential.

The National Construction Code (NCC) volumes cover requirements for weatherproofing, condensation, water vapour, ventilation, air tightness and thermal performance which help manage associated risks and resist ingress of weather and groundwater into a building to minimise the impact on the health of occupants.

CSR provides several product options for thermal and moisture control, and use as air barriers. The project designer, architect or engineer is responsible for determining what is appropriate for the application.

Weatherproofing

The control of water ingress to a building is the responsibility of the building designer. All framing, wall wrap/sarking, flashings, damp proof courses and sealants must be installed in accordance with design and installation guides, the relevant product manufacturer's instructions, applicable standards and building codes. The selection of the appropriate installation system is based on many factors, but particular attention must be paid to weatherproofing to ensure adequate long-term performance.

Important: Windows must be a front draining style and have appropriate flashing to prevent moisture ingress and penetrations should be effectively sealed and allow for differential movement between the air barrier and at the cladding.

Air Barriers

An air barrier behind the cladding is an essential part of the Commercial ExpressPanel weatherproofing system. The air barrier is required to reduce air leakage between the external and internal areas of the building. It is important to note that air barriers must be installed correctly as they are an integral element of a pressure equalised self-draining cavity system. The extent of the barrier, including the treatment at corners and at interactions with other facade elements, must be considered by the facade designer. Vertical cavity barriers may be required at some locations to ensure effective positive pressure

zones exist within the cavity, typically at building corners.

For conventionally installed wall wrap/vapour control membrane layers, typically the internal plasterboard lining is considered the predominant air barrier in the external wall system. Alternatively, the inner lining of the ventilated and drained cavity (i.e., wall wrap, rigid air barrier, waterproofing layer, backpan) can be the air barrier. The design must ensure the air barrier is structurally adequate to resist the imposed design wind pressures.

Properly designed rigid air barriers including, fibre cement, masonry, concrete, timber and metal sheeting all require respective detailing and sealing to be utilised as an air barrier. Alternatively, various properly designed wall wraps may be utilised. The maximum serviceability limit state wind pressure may be governed by the type of air barrier / air seal selected.

The serviceability wind pressure for the building is used to determine the suitability of a weatherproofing system. However, the design pressure for the air barrier is dependent on factors such as cavity depth, ventilation openings, and any panel gaps. The air barrier should be designed to resist the building ultimate wind pressure unless a lower value is determined by the facade engineer.

The Commercial ExpressPanel system with a cavity wall configuration using Cemintel Rigid Air Barrier has been tested and assessed to AS 4284 to withstand water ingress for serviceability limit state wind pressures up to +/- 2.5kPa, and a maximum design ultimate limit state wind pressures up to +/- 7.0kPa. Table 4.04 and Table 4.05 provide the ultimate design pressure capacity of the Cemintel Rigid Air Barrier for different structural framing arrangements and sheet orientations.

Wall wraps can provide a water resistant and air tight barrier when installed appropriately. When installed in accordance with the Soft Air Barrier construction details in this guide, the Bradford Enviroseal CW-IT wall wrap has been assessed as an air barrier for a maximum design ultimate limit state wind pressures up to +/- 2.5kPa. It is recommended that wall wraps used as an air barrier have an air resistance greater than 0.1 MNs/m³ when tested to ISO 5636-5. Wall wraps in Table 4.02 meet this air resistance requirement. The construction details for a soft air barrier or rigid air barrier are presented in the 'Construction Drawings and Details' section of this guide and the Cemintel Rigid Air Barrier Design & Installation Guide, respectively.



DESIGN + AESTHETIC CONSIDERATIONS

Condensation

Condensation occurs as warm, moist air cools and contacts cold surfaces that are below the air's dew point. Absorptive materials such as brick, cement sheet and timber are permeable and act as a buffering material until they become saturated, whilst nonabsorptive materials such as steel and glass reach saturation quickly. Water can then accumulate and must be allowed to dry or drain away via a cavity. Moist surfaces and the right environment can lead to mould, creating potential health issues for occupants and lead to degradation of building materials and loss of structural integrity.

The likelihood and severity of condensation is largely a function of:

- Climate (primarily temperature and humidity including seasonal and diurnal variations).
- Occupancy and building use.
- Material properties of the building envelope (including insulation material type and R-Value).
- Passive and mechanical ventilation.
- Air tightness.
- The building envelope's ability to allow or prevent the movement of vapour.
- The building envelope's ability to act as a water barrier behind the primary cladding element.
- The drying potential provided by a building envelope.

CSR recommends that architects/designers undertake a condensation risk analysis prior to selecting vapour control membranes. A rigid air barrier may be required where buildings are subject to higher wind loads, and in some climate zones may require the incorporation of a vapour control membrane in addition to the rigid air barrier. Greater use of insulation, better sealing to restrict air movement, and increased use of air conditioning leads to larger differences between the temperature and water vapour content of indoor environments and adjacent outdoor areas and greatly increases the risk of condensation at surfaces and interstitial spaces.

The Australian Building and Construction Board (ABCB), "Condensation in Buildings - Handbook", Print Version 3.2, June 2023, discusses the condensation risks and provides guidance on managing condensation. This guidance includes

review of Bureau of Meteorology climate statistics (including maximum and minimum average monthly temperatures together with average monthly dew point temperatures). This highlights the likelihood of condensation which occurs when minimum temperature falls below the dew point and identifies the daytime drying potential.

Vapour Control/Vapour Permeable Membranes

The fabric of the building separates the interior and exterior environments and is subject to the movement of heat, air, water, and water vapour. Multiple materials are usually required to form effective control layers in the interstitial spaces between the exterior cladding and internal lining of a building.

The appropriate wall wrap for an application will depend on the local climate, building type, service wind pressure, use and orientation, material R-Value of the insulation, as well as the degree and location of ventilation.

Vapour barriers restrict the transmission of water vapour, while vapour permeable membranes allow the transmission of water vapour.

The wall wrap must have a 'water barrier' classification to AS/NZ 4201.4. A non-water barrier classification is not suitable. Wraps included in this manual, and Cemintel Rigid Air Barrier, have achieved the classification water barrier. Wall wraps must meet the requirements of AS/NZS 4200.1: Pliable building membranes and underlays – Materials and be installed in accordance with AS 4200.2 – Pliable building membranes and underlays – Installation requirements.

For conventionally installed wall wraps, the requirement to seal joints and penetrations may vary depending upon NCC, AS 4200.2 and/or state requirements, CSR recommends sealing the external wall wrap/sarking to maintain vapour and wind performance, and draught proofing effectiveness, as well as to ensure water barrier integrity. As there are a number of factors that need to be considered in assessing and managing condensation risk.

Additional literature on this subject is available from CSIRO/BRANZ/ASHRAE/ABCB and CSR DesignLINK can help with this assessment.

DESIGN + AESTHETIC CONSIDERATIONS

**TABLE 4.01** Recommended CSR Products for Moisture Management of Walls

Climate Zone	Guidance on Vapour Control	Performance and Category	Recommended CSR Products ⁽¹⁾ (Refer to Table 4.02)
Warm humid, High humidity or Hot-dry (tropical, coastal, inland) climates (Zone 1, 2, 3)	Where vapour flow is typically inward, such as where the building is airconditioned for cooling, the membrane should function as a vapour barrier. Climates with varying diurnal and seasonal temperature changes can affect the direction of the water vapour flow. In most cases a vapour permeable membrane outside the insulation is recommended to avoid creating a moisture trap, allowing drying in either direction.	Vapour Barrier Class 1 or 2 or Vapour Permeable Class 3 or 4	<ul style="list-style-type: none"> • Bradford Enviroseal Aero • Bradford Thermoseal Wall Wrap • Bradford Thermoseal Wall Wrap XP • Cemintel Rigid Air Barrier with a vapour barrier membrane • Cemintel Rigid Air Barrier • Bradford Enviroseal Plus/CW/CW-IT Wall Wrap
Hot-Dry or Warm Temperate (coastal & inland) climates (Zones 4, 5)	These climates have varying diurnal and seasonal temperature changes that can affect the direction of the water vapour flow. A vapour permeable membrane outside the insulation is required to avoid creating a moisture trap, allowing drying in either direction. Where a high level of thermal insulation is used, a high degree of permeability may be required.	Vapour Permeable Class 3 or 4	<ul style="list-style-type: none"> • Bradford Enviroseal Aero • Bradford Enviroseal Plus/CW/CW-IT Wall Wrap • Cemintel Rigid Air Barrier
Mild or Cool Temperate, or Cold (alpine) climates (Zones 6, 7, 8)	Where there is a strong tendency for outward migration of vapour and a high risk of condensation, vapour permeable membranes should be installed on the cold, external side of the insulation.	Vapour Permeable Class 4	<ul style="list-style-type: none"> • Bradford Enviroseal Aero • Bradford Enviroseal Plus/CW/CW-IT Wall Wrap

(1) Expert guidance based on local experience should be sought.

TABLE 4.02 Vapour Control Properties of CSR Products

Product	Vapour Permeance Class AS/NZS 4200.1	Vapour Permeance ASTM E 96 (µg/N.s)	Weather Exposure Limit Prior to Cladding
Bradford Thermoseal Wall Wrap XP	Class 2	0.0022 to 0.1429	6 weeks
Bradford Thermoseal Firespec	Class 2	0.0022 to 0.1429	6 weeks
Bradford Thermoseal Wall Wrap	Class 2	0.0022 to 0.1429	6 weeks
Cemintel Rigid Air Barrier	Class 3	0.25	6 months (panel) 2 months (tape)
Bradford Enviroseal Aero	Class 4	> 1.1403	6 weeks
Bradford Enviroseal CW/CW-IT Wall Wrap	Class 4	> 1.1403	6 weeks
Bradford Enviroseal RW Wall Wrap	Class 4	> 1.1403	6 weeks

DESIGN + AESTHETIC CONSIDERATIONS

Cemintel Soft Air Barrier

Soft Air Barrier to be installed in the following wind load situations

TABLE 4.03 Wall Wrap and Plasti-Grip spacing requirements for the following wind loads

Stud Spacing (mm)	Maximum Bradford Plasti-Grip Washer Spacing (mm)								
	Ultimate Design Wind Pressure (kPa)								
	0.50	0.75	1.00	1.25	1.50	1.75	2.00	2.25	2.50
300	300	300	300	300	300	300	300	300	300
400	300	300	300	300	300	300	250	250	200
450	300	300	300	300	300	250	250	200	200
600	300	300	300	300	250	200	-	-	-

Note: Screw fixings for attaching washers to timber or steel framing shall be a minimum 8g self-drilling screws. Screws into timber shall have a minimum 25mm embedment.

Cemintel Rigid Air Barrier

Cemintel Rigid Air Barrier sheet installed in the vertical direction

TABLE 4.04

Stud Centres (mm)	Maximum Wind Loading (Ultimate) (kPa)
600	1.14
450	2.03
400	2.57
300	4.57

Cemintel Rigid Air Barrier sheet installed in the horizontal direction

TABLE 4.05

Stud Centres (mm)	Maximum Wind Loading (Ultimate) (kPa)
600	1.76
450	3.13
400	3.96
300	7.00

Note: For specific installation information on Rigid Air Barrier, refer to the 'Cemintel Rigid Air Barrier Design and Installation Guide'.

Energy Efficiency & Thermal Design

Energy efficiency requirements for buildings are set out in the NCC, as performance requirements and acceptable construction practices, and are dependent on geographical climate zones. To meet the requirements, it is recommended that insulation be installed in the wall framing and provision of appropriate sealing of the building envelope. Check with local building authorities for minimum insulation requirements. The level of insulation provided by a wall is described by its Total R-Value.

Thermal Performance of Cemintel Wall Systems

The Gyprock The Red Book presents Cemintel external wall systems that include thermal ratings expressed as $R_{i(WINTER)}$ and $R_{i(SUMMER)}$ to represent Total R-values for the winter and summer design conditions as required by AS/NZS 4859.1, which is called upon in the NCC.

The Total R-Values presented in The Red Book are based on assumptions in accordance with the methods of AS/NZS 4859.1 – Thermal insulation materials for buildings - General criteria and technical provisions. Any included bulk insulation is a CSR Bradford product that has a material R-value

compliant with the standard, and building elements have thermal values sourced from the AIRAH handbook. Thermal performances quoted are based on an assessment through the insulation path. The contribution to Total R-Values depends on installation, workmanship and environmental conditions and it is assumed that cavities are ventilated.

Thermal Bridging

Thermal bridging is a path of least resistance for heat to travel, which can significantly reduce the effectiveness of insulation. An example is where a steel stud with high thermal conductivity interrupts the insulation layer. This can result in internal heat loss on a cold day and internal heat gain on a hot day. At thermal bridging locations, condensation may occur where warm, moist air contacts a colder surface.

The detrimental impact of a thermal bridge can be diminished with the installation of a thermal break, which increases the resistance for heat to travel at the thermal bridging locations. Typically, the thermal break has low thermal conductivity.

DESIGN + AESTHETIC CONSIDERATIONS



Thermal Break

For some situations, e.g. Class 2 building or Class 4 parts of a building, an envelope consisting of a metal framed wall with and external fibre-cement cladding and an internal lining directly fixed to the frame, NCC 2022 Amdt 2 J3D6 (1) [2019: J0.5] requires a thermal break to be installed between all points of contact between the external fibre-cement cladding and the metal frame. The thermal break shall have a minimum R-Value of R0.2.

The Australian Building Codes Board (ABCB) has produced a series of energy efficiency handbooks for housing, apartment and commercial applications, and outlines the methods for assessing thermal bridging and thermal break requirements. For direct fix cladding installations where the cladding is installed directly onto metal framing, the designer may need to include thermal breaks in the external wall system.

The Cemintel ExpressWall Top Hat Framing System removes the direct contact of the cladding with the metal framing and need for a thermal break. Insulation may be installed to the rear of the cavity to provide an insulation layer over the metal framing which can reduce thermal bridging and enhance the Total R-Value of the external wall system.

The Commercial ExpressPanel systems have a 'well ventilated' cavity and the project designer, architect or engineer is responsible for assessing the thermal bridging and determining the thermal break requirements to ensure the wall system provides an adequate Total R-Value inclusive of thermal bridging.

For the Cemintel direct fixed wall systems, the external cladding is in direct contact with the metal framing a thermal break is applied to the face of the frame to meet the deemed to satisfy requirements of the NCC.

NCC Requirements

NCC 2022 includes changes to energy efficiency requirements. These requirements will express the R-Value of the building fabric system as the Total R-Value inclusive of thermal bridging. The Total R-Value will consider the project specific external wall configuration and materials used, so that the detrimental impact of the thermal bridging on the added insulation is captured.

Additional to the effects of thermal bridging through the framing paths of the structure, the designer will need to allow for the following:

- gaps in the bulk insulation layer in the wall system due to structural framing (i.e., studs, noggings, perimeter of wall openings) and services obstructing or limiting wall insulation coverage;
- slab edge insulation;
- wall cavity ventilation; and
- the effects of air leakage due to unsealed architraves, unsealed door jambs, unsealed gaps between windows and the masonry wall or services penetrating the inner leaf.

These effects are to be compensated for as outlined in Section J of the NCC.

For projects conforming to NCC versions prior to the NCC 2022, thermal bridging consideration is not required in the Total R-Value calculation for all building classes, such as:

- Class 1 to Class 10 buildings (all building classes) for NCC 2016 Amdt. 1 Volume One and NCC 2016 Amdt. 1 Volume Two (and earlier).
- Class 1 and Class 10 only for NCC 2019 (incl. Amdt. 1) Volume Two.

For product information, refer to 'Components' section of this guide. Note, the insulation also improves the acoustic performance of the wall against outside noise.

Building Envelope Sealing

Building envelope sealing is pertinent to the energy efficiency performance of a building. NCC 2022 Amdt 2 J1V4 [2019: JV4] outlines a method to verify compliance with the building sealing requirements in NCC 2022 Amdt 2 Part J5 [2019: Part J3].

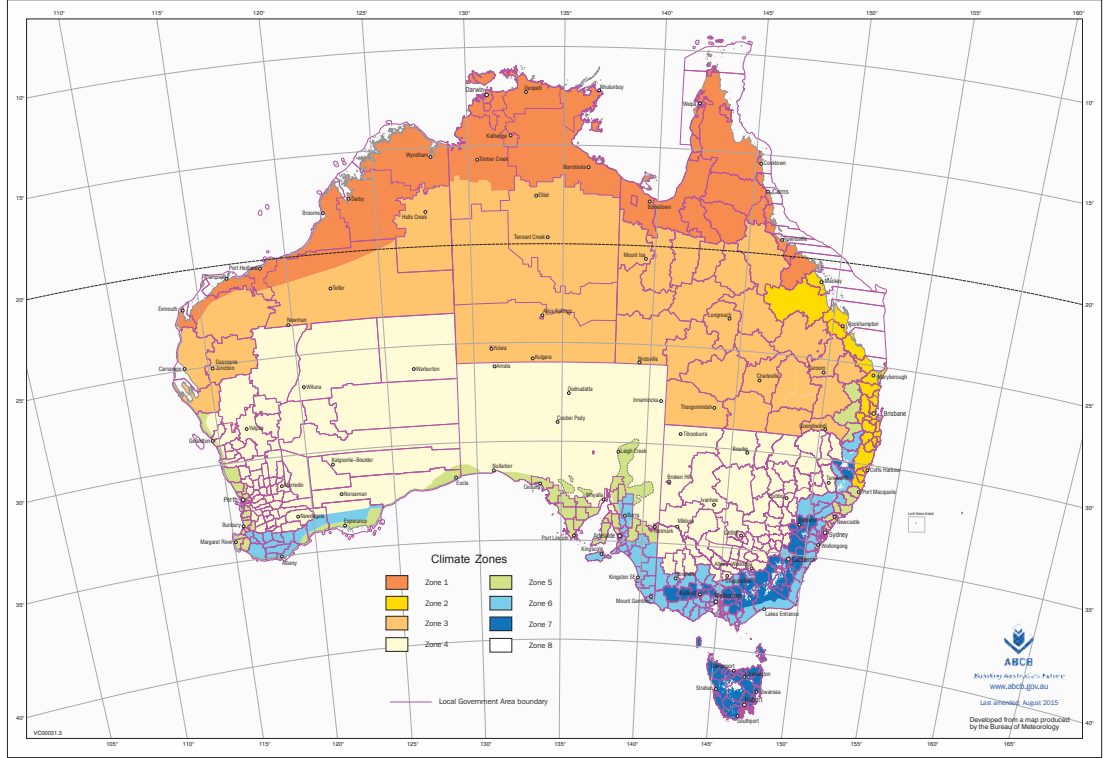
Solar Reflectance/Absorptance

Cemintel Commercial Express has been tested to ASTM E 903-96 'Standard Test Method for Solar Absorptance, Reflectance and Transmittance of Materials Using Integrating Spheres'.

DESIGN + AESTHETIC CONSIDERATIONS

Climate Zones for Thermal Design

The following map and tables show the performance levels required for walls (and floors) under the NCC.



- Step 1:** Determine which climate zone your project is located in Australia from the map above.
 - Step 2:** From Table 4.06, determine the design conditions ('Summer' heat flow in or 'Winter' heat flow out) according to the building class and climate zone for your project. (Note building classes are defined by the NCC.)
 - Step 3:** Refer to the roof, wall or floor system applicable to your construction type to determine Total R-Value.
- Note: Some applications may achieve Total R-Values sufficient to comply with the minimum performance levels of the Deemed-to-Satisfy requirements contained in the Energy Efficiency Provision of the NCC.

TABLE 4.06 Design Conditions ('Summer' heat flow in or 'Winter' heat flow out). Source: ICANZ Handbook.

Climate Zone	1	2	3	4	5	6	7	8
		<300m Altitude	>300m Altitude					
Class 1&10	Summer	Winter						
Class 2-9	Summer						Winter	

DESIGN + AESTHETIC CONSIDERATIONS



Fire Performance

Façade Fire Performance

With respect to the Deemed-to-Satisfy requirements of NCC 2022 Amdt 2 Volume One, C2D10 [2019: C1.9] allows that fibre-reinforced cement sheeting may be used wherever a non-combustible material is required. Cemintel Commercial ExpressPanel is fibre-reinforced cement sheeting and is therefore suitable as a component of, for example, external walls of buildings that are of Type A or B construction. A similar allowance is made in the Acceptable Construction section of NCC 2022 Amdt 2 Volume Two.

Bradford Enviroseal and Thermoseal products are also suitable for use where a non-combustible sarking-type material is

required as they do not exceed 1mm in thickness and have a Flammability Index ≤ 5 .

Fire Rated Wall Construction

Cemintel Commercial ExpressPanel can be used in conjunction with Gyprock fire grade plasterboard as part of a fire rated wall. Systems may be selected from Gyprock The Red Book series of; The Red Book 01, The Red Book 02 and The Red Book 03.

Extreme Climate Conditions

Bushfire Zones

A Bushfire Attack Level (BAL) rating is a means of measuring the severity of a building's potential exposure to ember attack, radiant heat and direct flame contact. It is the responsibility of the project designer to assess the bushfire adequacy of the wall system and determine any additional details to satisfy the project bushfire requirements (refer to the NCC, AS 3959 and any other relevant regulatory requirements).

Protection against bushfire attack requires a comprehensive and systematic approach to ensure the construction of the whole wall system is considered, that includes the specification of fire-resistant linings, framing, cavity treatment and other materials (e.g., insulation, external wall cladding), and construction details for the external walls and junctions to neighbouring elements (e.g., eaves, decks and floors). Bushfire zone walls require specific treatments, such as but not limited to, all joints in the external surface material (cladding) of walls shall be covered, sealed, overlapped, backed or butt-jointed, inclusion of a sarking-type material applied over the frame prior to fixing any external cladding, and at all gaps (e.g., vents and weepholes) in external walls shall be screened with a mesh with a maximum aperture of 2mm, made of corrosion-resistant steel or bronze. Also mesh coverings maybe required at the wall head, base, all gaps, eaves and junctions with roofs, etc., to ensure appropriate protection from fire and ember attack.

In accordance with AS 3959, the Cemintel Commercial ExpressPanel sheets comply with the minimum thickness requirements of fibre-cement external cladding of Section 8 Construction Requirements for Bushfire Attack Level 40 (BAL-40) for an external wall. Commercial ExpressPanel wall systems can be suitable for use on buildings constructed in accordance with AS 3959 with a BAL rating up to and including BAL-40.

Cemintel Commercial ExpressPanel wall systems can achieve a 30/30/30 FRL rating (or higher) from the outside with the addition of a suitable Gyprock Fyrchek MR plasterboard lining to the outside of the framing, (refer to Gyprock The Red Book 01 Design Guide) and installed according to regulations and AS 3959 Section 9 Construction Requirements for Bushfire Attack Level FZ (BAL-FZ) for an external wall. Note that a 10m setback applies from the edge of the classified vegetation to the building.

Corrosive Zones

Consideration of corrosive zones should be taken into account. While Commercial ExpressPanel panels are not subject to corrosion, consideration needs to be made regarding the impact of climate conditions on system components such as screws, rivets and metal framing.

Atmospheric Corrosivity Categories are detailed in AS 4312-2019 and set out in Table 4.08 at the end of this section.

Commercial ExpressPanel wall system of Commercial ExpressPanel panels installed with the Cemintel ExpressWall Top Hat Framing System may be used in corrosivity categories up to and including C3 – Medium.

Walls must be sufficiently exposed from above so that rain can perform natural wash-down of the wall. Otherwise, all walls which are protected by soffits must be washed down twice per year to remove salt and debris build up, particularly around window/ door openings.

Note that a white deposit may develop on stainless screw heads over time. This can be prevented by regular washdown of the façade and the fastener heads.



DESIGN + AESTHETIC CONSIDERATIONS

The Architect/Building Designer is responsible for assessing the site in accordance with the standard and local conditions, such as local weather and topographical features that can cause an increase in the distance that salt spray can travel beyond the limits detailed in AS 4312.

Commercial ExpressPanel panels are not suitable for Corrosivity Zone C5 – Very High. This includes the beachfront in regions of rough seas and surf beaches, and inland for several hundred metres, e.g., around Newcastle extending over half a kilometre from the coast. It also includes aggressive industrial areas where the environment may be acidic with a pH of less than 5.

Corrosivity Categories

ISO 9223 has suggested five corrosivity zones based on the first year corrosion rate of mild steel. Refer to AS 4312 – 2019 for details regarding Australian Atmospheric Corrosivity Categories.

Cyclonic Zones

Cyclonic testing on the ExpressWall system has been successfully carried out for positive and negative wind pressures of up to 7.0 kPa. **In cyclonic areas, ExpressWall Top Hat and Intermediate Top Hat sections of 1.15mm BMT must be used and a minimum 14-G hex head screws are required for fixing top hats to steel sub-framing.** Wind loads in this guide refer to ultimate limit state design wind pressures.

Temperature Extremes

Commercial ExpressPanel External is not warranted for use in freezing conditions where the ExpressPanel is in contact with snow drifts or extremely hot conditions (that is above 60°C).

Some general statements from this document are below.

Wind loads in this guide refer to ultimate limit state design wind pressures.

TABLE 4.07

ISO 9223 Category	Corrosivity	Steel Corrosion rate $\mu\text{m}/\text{y}$	Typical environment
C1	Very low	<1.3	Dry indoors
C2	Low (most areas of Australia at least 50km from the coast or at least 1km from sheltered bays would be in this category)	1.3-25	Arid/urban inland
C3	Medium (from 1km to 10-50km from breaking surf – much of metropolitan Wollongong, Sydney, Newcastle and Gold Coast are in this category)	25-50	Coastal or industrial
C4	High (primarily coastal areas - from several hundred metres to about 1km inland from breaking surf or from the shoreline to around 50m for sheltered bays)	50-80	Sea shore (calm)
C5	Very high (industrial or marine) – common offshore and on the beachfront in regions of rough seas and surf beaches – can extend inland for several hundred metres (in some areas of Newcastle extends around 500m)	80-200	Sea shore (surf)
CX	Extreme (industrial or marine) - found on offshore structures and within 50m inland of the shoreline of coasts exposed to surf or very rough seas - can extend 200m under the most severe sea conditions and 100m in tropical locations.	200 - 700	Sea shore (severe surf) of exposed coasts

Other Design Considerations

Services

The ExpressWall fixing system will accommodate services that are run through the framing. Any notches or holes formed must be considered in the framing design.

Renovations

When undertaking building renovations, remove all cladding, wall wrap/sarking and insulation from the original wall framing. Ensure the condition of the framing is in accordance with current requirements and is as true and as plumb as possible (within accepted industry tolerances of 5mm misalignment over 3000mm).

Install additional framing, insulation, air barrier and flashing as required.

Limitations

Commercial ExpressPanel is not suitable for the following applications:

- Panels with non-vertical face (e.g. parapet capping).
- Wet areas such as bathrooms.
- Chimney cladding.
- Exposure to temperatures greater than 60°C.
- Roofs, parapet cappings, sills and similar horizontal or near horizontal surfaces.
- Contact with standing snow or ice.
- Fixing of tiles or other materials to the face of the panels as the face is prefinished.

The above listing is not intended to be comprehensive. If in doubt, please contact Cemintel.

DESIGN + AESTHETIC CONSIDERATIONS



Wash Down Process

Panels have been coated with a factory finish. Consequently, where sufficiently exposed, rain can perform a natural wash down of the wall and ongoing maintenance should be limited to occasional rinse down or using a soft cloth or soft brush (like a dust pan brush).

Walls which are protected by soffits above must be washed down twice per year to remove salt and debris build up particularly at joints.

When cleaning the panels the following is recommended –

- Normal dirt can be removed with a soft brush and warm water up to 50 degrees Celsius, to which a small amount of dishwashing liquid or soap has been added. The panels should be rinsed with clear water before they dry.
- Calcifications should be removed with a 5% sulfamic acid solution or with a commercial lime remover. The façade should be rinsed with clear water after cleaning.
- Panels discoloured by algal growth should be treated with an algicide without bleaching agents. This application should be allowed to take effect for several days. Afterwards, clean the panels using the 'normal dirt' procedure above.
- When rinsing down panels, use no more than 700 psi (50kh/cm²) of water pressure at a minimum of 3m distance from the face of the wall. Water pressure should be applied downward to avoid forcing water into joints.
- Use neutral detergent with a soft cloth or soft brush when removing dirty spots from a panel. When diluting the neutral detergent, follow the manufacturer's instructions and use the weakest solution possible.

Inspection, Repair and Maintenance

The durability of the Cemintel Commercial ExpressPanel range can be enhanced by periodic inspection and maintenance. Inspections should include examination of the coatings, flashings and seals. Any cracked or damaged finish or seals which would allow water ingress must be repaired immediately by resealing the affected area, or by removing the panel and replacing sealant. Any damaged flashings, sheets or sealant must be replaced as for new work.

Regularly inspect panel surfaces and follow wash-down procedures when required.

Ensure ventilation and drainage gaps between panels and flashings are clear of any debris.

A large, stylized number '05' is rendered in white outline font against a solid reddish-brown background. The '0' is a simple oval, and the '5' has a distinctive stepped top edge. The number is positioned in the lower half of the page.

05

COMPONENTS + ACCESSORIES

COMPONENTS + ACCESSORIES

05

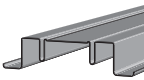
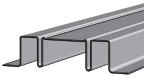
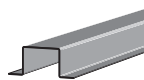
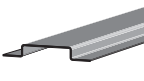






Note: Codes can change from time to time. Refer to the website for the current list of components prior to ordering.

Panels

Product Code	Thickness (mm)	Width (mm)	Length (mm)	Mass (Nominal)	Panels per pack
25681	9	900	1800	17.8kg/m ²	20
25682	9	900	2400	17.8kg/m ²	20
25683	9	900	3000	17.8kg/m ²	20
25676	9	1200	1800	17.8kg/m ²	20
25677	9	1200	2100	17.8kg/m ²	20
25678	9	1200	2400	17.8kg/m ²	20
25679	9	1200	2700	17.8kg/m ²	20
25680	9	1200	3000	17.8kg/m ²	20

Accessories

Note: The length of the fixings will need to be increased to ensure the same or greater embedment depth is obtained when additional layers are added, such as a Rigid Air Barrier (RAB), fire-rated linings, and/or thermal break materials.




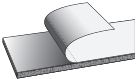
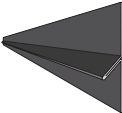








Accessories	Description	Size / Colour	Quantity	Product Code
TOP HATS				
	ExpressWall Top Hat – is a purpose designed rolled steel section for supporting the vertical edges of the panels. The unique profile also acts to accommodate movement of the panels at the vertical joints. It is designed to be used in conjunction with the ExpressWall vertical gasket. Screws must be carefully installed in 0.75mm BMT ExpressWall Top Hat to avoid thread stripping.			
	ExpressWall Top Hat 0.75BMT – mass = 1.97kg/m	6000mm	1 each	84746
	ExpressWall Top Hat 1.15BMT – mass = 3.25kg/m (suitable for cyclonic zones – use with exposed head screws).	6000mm	1 each	39124
	Intermediate Top Hat – is used to support the panels at locations other than vertical joints. Intermediate top hat is a Rondo rolled steel section which is manufactured from galvanised steel (Z275) of 0.75mm BMT and 1.15mm BMT. Screws must be carefully installed in 0.75mm BMT Intermediate Top Hat to avoid thread stripping.			
	Intermediate Top Hat 1.15BMT – mass = 1.37kg/m	3600mm	1 each	21086
	Intermediate Top Hat 1.15BMT – mass = 1.37kg/m	7200mm	1 each	21083
	Intermediate Top Hat 0.75BMT – mass = 0.89kg/m	3000mm	1 each	126144
	H515 Top Hat – is fixed to structural steel framing to support the ExpressWall and Intermediate Top Hats. Top Hat H515 is a Rondo rolled steel section which is manufactured from galvanised (Z275) steel of 1.15mm BMT.			
	Top Hat H515 15x50x15mm 1.15BMT – mass = 0.91kg/m	3600mm	1 each	12884
	Top Hat H515 15x50x15mm 1.15BMT – mass = 0.91kg/m	6000mm	1 each	454074
FASTENERS				
	Hex Head Screws – for fixing vertical ExpressWall Top Hats and Intermediate Top Hats to H515 or steel framing of minimum 1.15mm BMT in non-cyclonic areas. Hex head self drilling screw 12G-14x20mm, Class 3.	12G-14 x 20mm	1000 per pack	84882
	Hex Head Screws – for fixing horizontal H515 Top Hats to steel framing minimum 0.75mm BMT and for fixing ExpressWall Top Hats and Intermediate Top Hats to H515 or other steel framing of minimum 1.15mm BMT in cyclonic areas. Hex head self drilling screw 14G, Class 3.	14G minimum	Supplied by others	
	Hex Head Screws Type 17 – for fixing H515 top hats to timber framing in non-cyclonic areas. Hex head self drilling type 17 screw 12Gx25mm, Class 3.	12G x 25mm	Supplied by others	
	Commercial ExpressPanel Countersunk Head Screws	10G x 30mm	1000 per pack	114081
	Commercial ExpressPanel Countersinking Tool		1 each	114081
	Drill Bit Ø 6.0mm – 6.5mm – for drilling accurate holes to install Commercial ExpressPanel.		Supplied by others	

05

COMPONENTS + ACCESSORIES

Note: Codes can change from time to time. Refer to the website for the current list of components prior to ordering.

Note: The length of the fixings will need to be increased to ensure the same or greater embedment depth is obtained when additional layers are added, such as a Rigid Air Barrier (RAB), fire-rated linings, and/or thermal break materials.



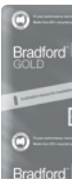
Accessories	Description	Size / Colour	Quantity	Product Code
	Exposed Head Screws 10Gx30mm Exposed Wafer Head Galvanised Class 3. The exposed head screw has a buttress thread which is designed to provide maximum holding power in light gauge steel. It is available in Class 3 finish. Suitable for 1.15mm BMT top hats.	10G x 30mm	1000 per pack	114070
	Exposed Head Screws 10Gx35mm Exposed Wafer Head SS302 (zinc coated stainless steel). The exposed head screw has a buttress thread which is designed to provide maximum holding power in light gauge steel. It is available in Stainless Steel (grade 302). Suitable for 1.15mm BMT top hats. Not suitable for use in C4 environments.	10G x 35mm	1000 per pack	122235
	Weather Seal Gasket. The ExpressWall weather seal is a grey, UV stabilised nylon washer. It is used with ExpressWall exposed head screws to provide an interference fit, delivering high weather resistance and acting to lock the screw into position.		1000 per pack	36484
GASKETS				
	ExpressWall Vertical Gasket - Gaska 1510 self-adhesive tape is made from closed cell PVC foam which has high UV resistance. The gasket has adhesive on one side (with a release paper) and is adhered to the ExpressWall Top Hat to prevent moisture entry at vertical points.	3.2mm x 48mm x 23m Black	1 each	133978
BACKING STRIPS				
	Angled Backing Strip – a rolled aluminium section designed to deflect water and create an attractive expressed joint appearance at horizontal joints. Suitable only where a non-sealed façade system is appropriate.	3040mm	1 each	132681
	ExpressWall Backing Strip – may be used in lieu of Surround Angled Backing Strip for sealant filled system option.	1194mm 2394mm 2994mm	1 each 1 each 1 each	21089 21088 21087
	Bond Breaker Tape – Tesa 7492. Required where horizontal joints are sealed.	3.2mm x 48mm x 25m	1 each	13172
OTHER				
	Corner Backing Angle – metal angle flashing used in some corners. Manufactured from steel with Galvalume AZ150 corrosion resistant coating.	50mm x 50mm x 3030mm	1 each	111498
	Adhesive – for fixing spacer at head junction. Sikaflex 11FC Grey For use as a backing strip adhesive when installing ExpressWall Backing strips	310mL tube	1 each	39378
	Sealant – is used to seal joints for control joints, junctions etc. Sikaflex Sealant PRO-2HP Grey	310mL tube	1 each	11378
	Backing Rod – for sealant backing – used to enable correct filling of joints with sealant. Also used as an air seal at window openings and construction junctions. The diameter of backing rod must be appropriate for the width of the gap being filled.	10mm diameter x 50m roll	1 each	11177
	Cemintel Edge Sealer – for sealing panel edges after on-site cutting.	200ml 2 litre	1 each 1 each	100166 180928
	Flashing & Capping – flashings are to be designed and installed in accordance with SAA-HB39 2015 and good building practice.	Supplied by others		
	Megapoxy P1 – Used to conceal the countersunk fastener heads, to prevent moisture penetration, and to provide a flat surface for decorative coating. Megapoxy products must be installed to the manufacturer's recommendations. In colder climates (eg. Tasmania), Megapoxy PF should be used.	1 litre	1 each	25464
	Polyfilla Pro Deep and Large Cracks – for final filling of countersunk screw holes following application of Megapoxy. Available from trade and specialty paint outlets.	Supplied by others		

COMPONENTS + ACCESSORIES

05

Note: Codes can change from time to time. Refer to the website for the current list of components prior to ordering.

Note: The length of the fixings will need to be increased to ensure the same or greater embedment depth is obtained when additional layers are added, such as a Rigid Air Barrier (RAB), fire-rated linings, and/or thermal break materials.

Accessories	Description	Size / Colour	Quantity	Product Code
CSR RIGID AIR BARRIER/WALL WRAPS				
Conventional installation of the Bradford sarking/wall wrap products shall be in accordance with Bradford instructions.				
	Cemintel Rigid Air Barrier*	1200mm x 3000mm x 6mm	Pack of 30 sheets	170076
	Bradford Enviroseal™ Plus Wall Wrap Classification – Class 4 Vapour Permeable	1350mm x 30m	1 roll	483000
		1500mm x 30m	1 roll	478759
		1500mm x 25m	1 roll	481184
		1500mm x 25m	1 roll	481185
	Bradford Enviroseal™ CW Wall Wrap Classification – Class 4 Vapour Permeable	1500mm x 50m	1 roll	114175
	Bradford Enviroseal™ CW-IT Wall Wrap Classification – Class 4 Vapour Permeable	1500mm x 50m	1 roll	134863
	Bradford Enviroseal™ Aero Wall Wrap Classification – Class 4 Vapour Permeable	1350mm x 30m	1 roll	488644
		1500mm x 30m	1 roll	488650
		1500mm x 30m	1 roll	489433
	Bradford Thermoeseal™ Wall Wrap Classification – Non-permeable reflective Water Barrier	1350mm x 30m	1 roll	40483
		1350mm x 60m	1 roll	15128
		1500mm x 30m	1 roll	40514
	Bradford Thermoeseal™ Firespec Classification – Non-permeable reflective Water Barrier	1500mm x 30m	1 roll	164674
Bradford Thermoeseal™ Wall Wrap XP Classification – Class 2 Wall Barrier	1350mm x 30m	1 roll	125825	
	1350mm x 60m	1 roll	124652	
	Bradford Hightack Tape – used to seal wall wrap at overlap joins, around openings, for repairs and at flashings in the Cemintel Rigid Air Barrier and Soft Air Barrier systems. Black, single sided, aggressive adhesive tape with a high initial grab and flexible carrier.	60mm x 25m	1 roll	155170
	ProctorPassive® YouByute® Flexi Tape – PE butyl rubber tape used for corners of openings in the Rigid Air Barrier and Soft Air Barrier systems. Store in dry location between +5°C to +25°C away from UV exposure.	80mm x 10m	1 roll	492735
	Enviroseal™ Double Sided Tape	24mm x 50m	1 roll	124873
Reinforced Aluminium Foil Tape	48mm x 50m	1 carton (24)	13054	
	Bradford Plasti-Grip Washers	45 x 5mm	1 carton (1000)	136770
INSULATION				
	Bradford Gold HP Wall Batts – R2.0 (75mm)	1160mm x 420mm	12 pack	153643
		1160mm x 570mm	12 pack	153648
	Bradford Gold HP Wall Batts – R2.5 (90mm)	1160mm x 420mm	9 pack	181430
		1160mm x 570mm	9 pack	181471
	Bradford Gold HP Wall Batts – R2.7 (90mm)	1160mm x 420mm	5 pack	152191
		1160mm x 570mm	5 pack	152197



* Cemintel Rigid Air Barrier can be made in a range of sizes. Minimum order quantities and lead times apply. Contact Cemintel for more information.

05

COMPONENTS + ACCESSORIES

Note: Codes can change from time to time. Refer to the website for the current list of components prior to ordering.





Note: The length of the fixings will need to be increased to ensure the same or greater embedment depth is obtained when additional layers are added, such as a Rigid Air Barrier (RAB), fire-rated linings, and/or thermal break materials.

Accessories	Description	Size / Colour	Quantity	Product Code
	Bradford Hightack Tape – used to seal wall wrap at overlap joins, around openings, for repairs and at flashings in the Cemintel Rigid Air Barrier and Soft Air Barrier systems. Black, single sided, aggressive adhesive tape with a high initial grab and flexible carrier.	60mm x 25m	1 roll	155170
	ProctorPassive® YouByute® Flexi Tape – PE butyl rubber tape used for corners of openings in the Rigid Air Barrier and Soft Air Barrier systems. Store in dry location between +5°C to +25°C away from UV exposure.	80mm x 10m	1 roll	492735
	Enviroseal™ Double Sided Tape	24mm x 50m	1 roll	121430
	Reinforced Aluminium Foil Tape	48mm x 50m	1 carton (24)	17366
	Bradford Plasti-Grip Washers	45 x 5mm	1 carton (1000)	136770

INSULATION

	Bradford Gold HP Wall Batts – R2.0 (75mm)	1160mm x 420mm	12 pack	152166
		1160mm x 570mm	12 pack	152192
	Bradford Gold HP Wall Batts – R2.5 (90mm)	1160mm x 420mm	9 pack	181430
		1160mm x 570mm	9 pack	181471
	Bradford Gold HP Wall Batts – R2.7 (90mm)	1160mm x 420mm	5 pack	152191
		1160mm x 570mm	5 pack	152197

OTHER TOOLS

	Makita Plunge Saw Kit (1300W) includes 1400mm guide rail and bonus 165mm fibre cement saw blade – excellent for cutting cement based sheets. Must be used with a dust extraction system.	165mm	1	165485
	Makita 165mm Fibre Cement Saw Blade – ideal for use with the Makita Plunge saw and other 165mm circular saws fitted with vacuum extraction systems	165mmx20x4T	1	165486
	Dust Extraction		1	Supplied by others
	Grinder Tool		1	Supplied by others



SYSTEM ENGINEERING



SYSTEM ENGINEERING

Design, Detailing And Performance Responsibilities

Commercial ExpressPanel System

Cemintel engages independent testing laboratories to test and report on the performance of a wall in accordance with the relevant Australian Standards. Consultants with relevant experience will use these test reports to provide opinions and assessments that extend the tested arrangement to include various on-site installation configurations and details that meet appropriate criteria performance.

Project Consultants (Structural, Fire, Acoustic, Etc.)

These consultants are typically responsible for the following:

- Opinions on expected laboratory performance of wall configurations that vary from actual test configuration, such as substitution products and components.
- Judgements about expected field performance using laboratory test reports and practical experience.
- Design, specification and certification of structural, fire, acoustic, durability, weather tightness and any other required performance criteria for individual projects.

This involves the design and selection of building elements, such as wall and floors and their integration into the building considering the following:

- Interface of different building elements and to the structure / substrate.
- Wall and floor junctions.
- Penetrations.
- Flashing issues.
- Room / building geometry.
- Acoustic and water penetration field-testing.

Design Responsibility

Panels, top hats and structural framing are required to resist wind loads that are specific to the building site. Additional 'local pressure factors' can apply to the panels and top hats in accordance with the wind code AS/NZS 1170.2. It is recommended that the Architect/Building Designer assigns the responsibility for the facade design to the Project Engineer. Once wind loads have been determined, top hat spans, fastener spacings, and sheet fixing details may be selected from the appropriate tables in this manual.

It is also the responsibility of the Architect/Building Designer to select the appropriate corrosivity category. Refer to appropriate details in this guide.

The performance levels of walls documented in this guide are either what is reported in a test or the documented opinion of consultants. Performance in projects is typically the responsibility of:

Project Certifier and/or Builder

These professionals are typically responsible for:

- Identifying the performance requirements for the project in accordance with the NCC and clearly communicating this to the relevant parties.
- Applicability of any performance characteristics supplied by Cemintel including test and opinions for the project.
- The project consultants' responsibilities detailed above if one is not engaged in the project.

Cemintel does not provide consulting services. Cemintel only provides information that has been prepared by others and therefore shall not be considered experts in the field.

Any party using the information contained in this guide or supplied by Cemintel in the course of a project must satisfy themselves that it is true, current and appropriate for the application, consequently accepting responsibility for its use.

It is the responsibility of the Architect/Building Designer and engineering parties to ensure that the details in this design guide are appropriate for the intended application.

The recommendations in this guide are formulated along the lines of good building practice, but are not intended to be an exhaustive statement of all relevant data.

Cemintel is not responsible for the performance of constructed walls, including field performance, and does not interpret or make judgements about performance requirements in the NCC in a specific project application.

Note: it is the responsibility of the Project Engineer to specify the connection of the top hats to the support structure. It is also the responsibility of the Project Engineer to calculate the wind loads for the cladding of a project.

SYSTEM ENGINEERING



ExpressWall Top Hat Framing System

The Cemintel Commercial ExpressPanel cladding is fixed to the ExpressWall Top Hat Framing System that consists of vertical top hats fixed to directly to supporting structural stud framing with or without horizontal top hat sections, or another structural support system (i.e., masonry or concrete wall), refer to Section 04 of this guide. The ExpressWall Top Hat Framing Systems consist of 0.75mm BMT or 1.15mm BMT thick G2 grade ExpressWall Top Hat and Intermediate Top Hat sections. Refer to Tables 6.01, 6.02, 6.03 to 6.04 for maximum spacing of the vertical ExpressWall Top Hat and Intermediate Top Hat sections, and horizontal H515 top hat sections.

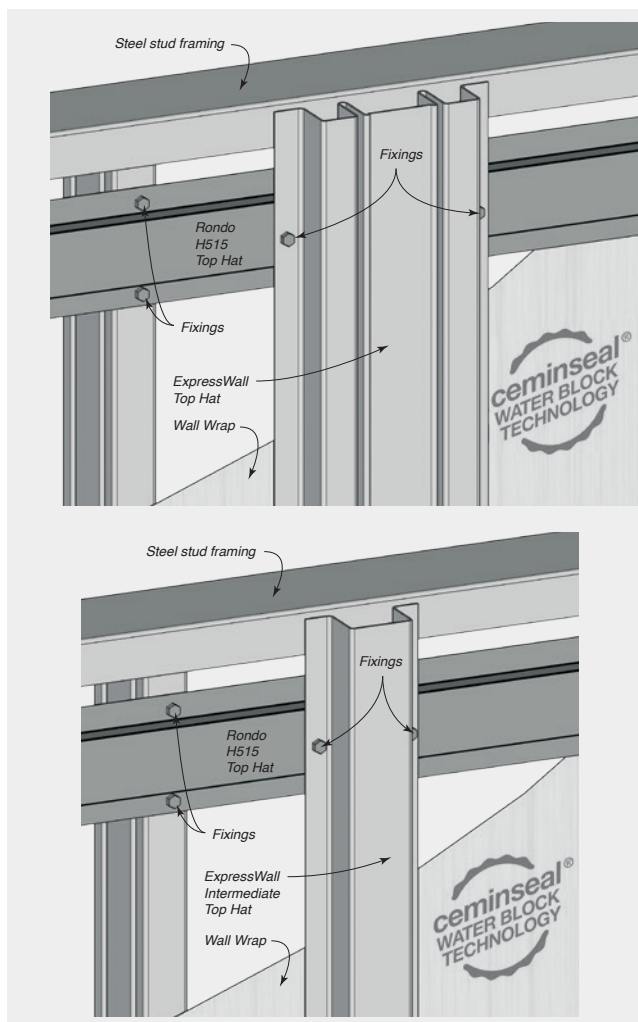
Note – the 1.15mm BMT ExpressWall Top Hat Framing System must be used for buildings located in cyclonic regions.

Structural Stud Framing with Horizontal Top Hat Supports

ExpressWall Top Hat and Intermediate Top Hat sections can be fixed via horizontal top hats to the vertical structural stud framing of designed MGP10 or higher grade timber stud framing, or a minimum 0.75mm BMT G2 grade steel stud framing. Refer to Figure 6.01.

The horizontal H515 top hats are fixed at top and bottom of the structural stud framing and at required equal spacings through the height of the wall. The stud frame walls shall be designed to meet the structural requirements of the project, as well as support the top hat configurations and Commercial ExpressPanel cladding.

FIGURE 6.01 ExpressWall Top Hats and Intermediate Top Hats fixed over horizontal H515 Top Hats, fixed to structural stud frames

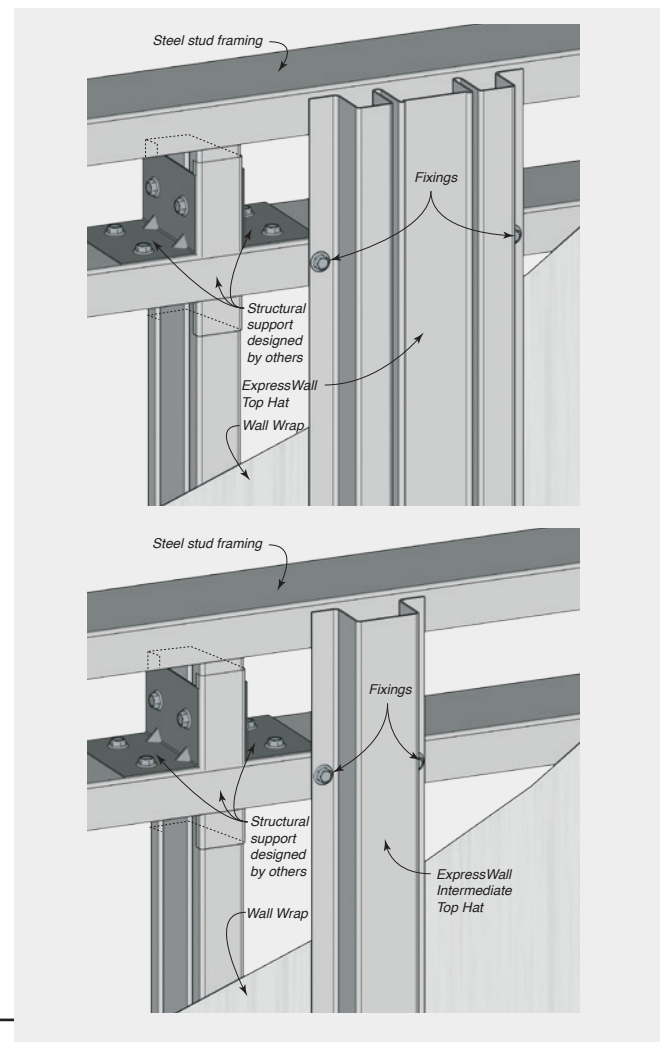


Structural Stud Framing and Wall Supports

Without the supporting horizontal top hats, the ExpressWall Top Hat Framing System may be fixed directly to equally spaced, structural designed horizontal sections within the supporting structural stud framing of MGP10 timber framing or a minimum of 1.15mm BMT G2 grade steel framing. It is the responsibility of the project engineer to specify the support structure.

Where top and/or bottom plate deflection is required, such as underside of inter-storey junction, the wall framing will require appropriately designed horizontal supports to provide the necessary support at the ends of the top hats. Refer to Figure 6.02.

FIGURE 6.02 ExpressWall Top Hats and Intermediate Top Hats fixed over horizontal structural wall supports





SYSTEM ENGINEERING

The ExpressWall Top Hat Framing System can be fixed to supporting stud framing, masonry and concrete walling. The maximum span in the design table can be used to determine the required equal spacings of the fixings. It is the responsibility of the project engineer to specify the fixings and adequacy of the support structure.

ExpressWall Top Hat Framing System and H515 Top Hats

The design capacities of the Cemintel Commercial ExpressPanel external wall system are in limit state format and intended for use with AS/NZS 1170.2.

To obtain equivalent permissible load capacity, divide the “ultimate wind capacity” in Table 6.03 or Table 6.04 by 1.5.

The top hat capacities have been calculated in accordance with AS/NZS 4600: Cold Formed Steel Structures and are applicable combinations of ExpressWall Top Hat and Intermediate Top Hat sections of 0.75mm BMT or 1.15mm BMT G2 steel grade, and H515 top hats of 1.15mm BMT G2 steel grade. The deflection of the top hats as detailed in these tables is no more than span/250 when subjected to serviceability wind load of 68% of ultimate wind loads.

In cyclonic regions, the Cemintel Commercial ExpressPanel external wall system shall use the 1.15mm BMT ExpressWall Top Hat Framing System and top hats fixed with 14g hex head screw fixings.

The spacing of the vertical top hats will vary depending on wind loads and support arrangement of the Commercial ExpressPanel panels, such as Single Spans (Refer Figure 6.03) or Double Spans (Refer Figure 6.04). Top hat spacing is nominal and may be increased by up to 20mm to accommodate panel joint width.

The horizontal H515 top hats shall be fixed to steel stud framing of minimum 0.75mm BMT with 2 x 14g hex head screws at each stud, and a MGP10 or higher grade timber stud framing with 2 x 12g-11TPI x 25mm Type 17 hex head screws at each stud.

The vertical ExpressWall Top Hat and Intermediate Top Hat sections shall be fixed to horizontal H515 top hats or directly to structural steel support framing of minimum 1.15mm BMT, use 2 x 12g-14TPI x 20mm.

Wall systems with additional external linings, such as Cemintel Rigid Air Barrier, Gyprock Fyrcek MR plasterboard and Gyprock Glasroc X plasterboard, will require longer screws to fix the H515 top hats to the supporting structural stud framing to achieve the same or greater embedment depth and ensure the screw is effectively installed. Refer to Figure 6.11.

The maximum allowable cantilever length of the vertical top hats is 20% of the adjacent top hat span.

FIGURE 6.03 Single Top Hat Span Installation

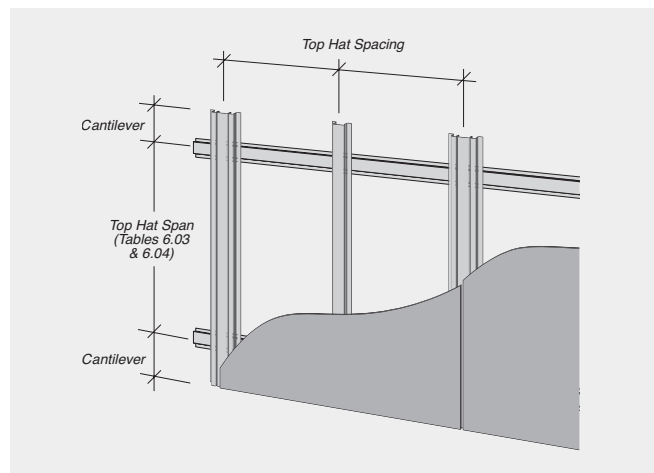
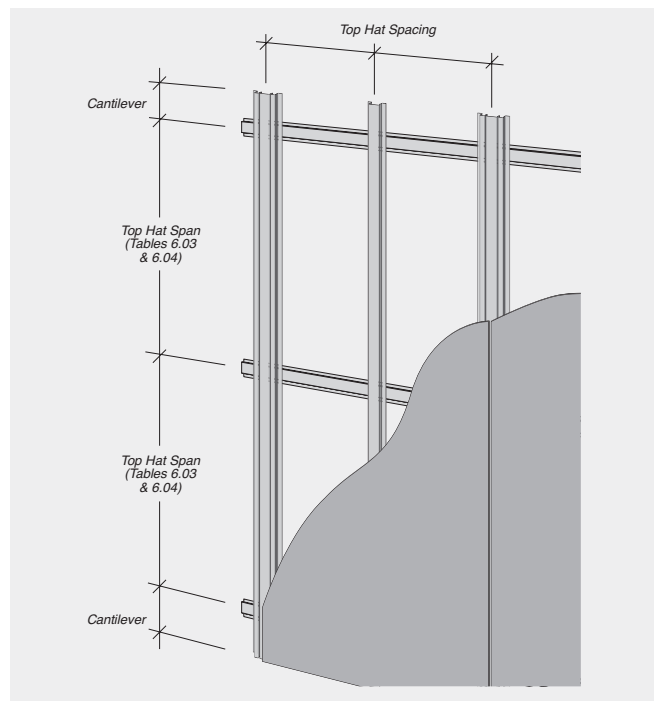


FIGURE 6.04 Double Top Hat Span Installation



SYSTEM ENGINEERING



Panel Fixing Requirements

Commercial ExpressPanel sheets that are pre-drilled and pre-painted offsite may be fixed to ExpressWall Top Hat Framing System using ExpressWall Exposed Head Screws (10g x 30mm minimum Wafer Head ExpressWall Exposed Head Screws, fine or buttress thread, Class 3 or stainless steel) or Commercial ExpressPanel stainless steel rivet fasteners (4 x 18mm shaft, 15mm head).

Countersunk head screws can be used with 1.15mm BMT ExpressWall Top Hat Framing System.

The maximum spacing of the fixings are shown in Tables 6.01 to 6.04. The layout of the fixings is shown in Figures 6.05 to 6.08.

Care should be taken when fixing screws to 0.75mm BMT top hats as screws can strip in the lighter gauge steel. The use of a screw gun with torque control to prevent overdriving screws is recommended.

FIGURE 6.05 Vertical Sheet Fixing

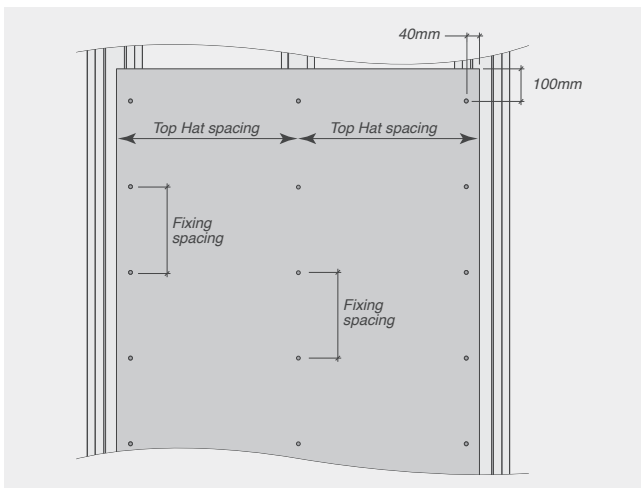


FIGURE 6.07 Panel Fixed to Two Top Hats Only



FIGURE 6.08 Panel Fixed to Three or More Top Hats

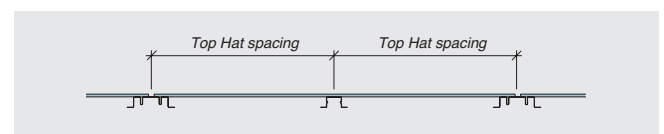
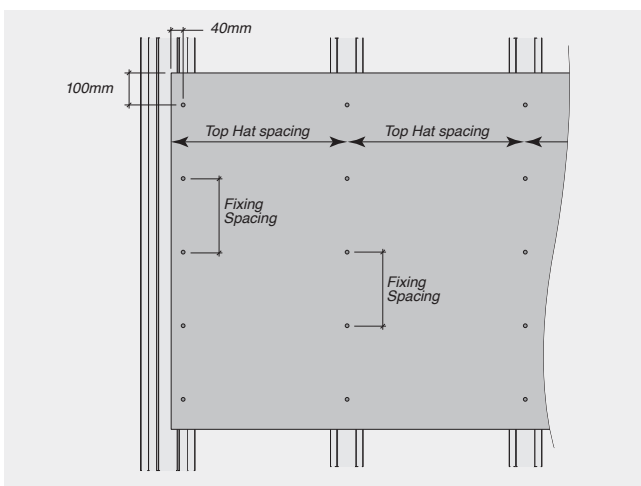


FIGURE 6.06 Horizontal Sheet Fixing





SYSTEM ENGINEERING

Design of ExpressWall Top Hat Framing System

Design tables are provided for the 0.75mm BMT and 1.15mm BMT ExpressWall Top Hat Framing Systems with the following information based on the Design Wind Pressure –

- For the Commercial ExpressPanel cladding, the allowable maximum horizontal spacing of vertical ExpressWall Top Hat Framing and maximum fixing spacing.
- For the ExpressWall Top Hat Framing, the allowable maximum span of the vertical top hats.

- For H515 top hat supports, the maximum vertical spacing of the horizontal H515 top hats fixed to the supporting structural stud framing of MGP10 timber framing or a minimum of 0.75mm BMT G2 grade steel framing.
- For other supports, the maximum span of the ExpressWall Top Hat Framing sections. Note: the connection shall be designed by the project engineer.

The typical layout the ExpressWall Top Hat Framing System over structural support systems are shown in Figure 6.09 and Figure 6.10.

FIGURE 6.09 ExpressWall Top Framing System over Structural Support Systems

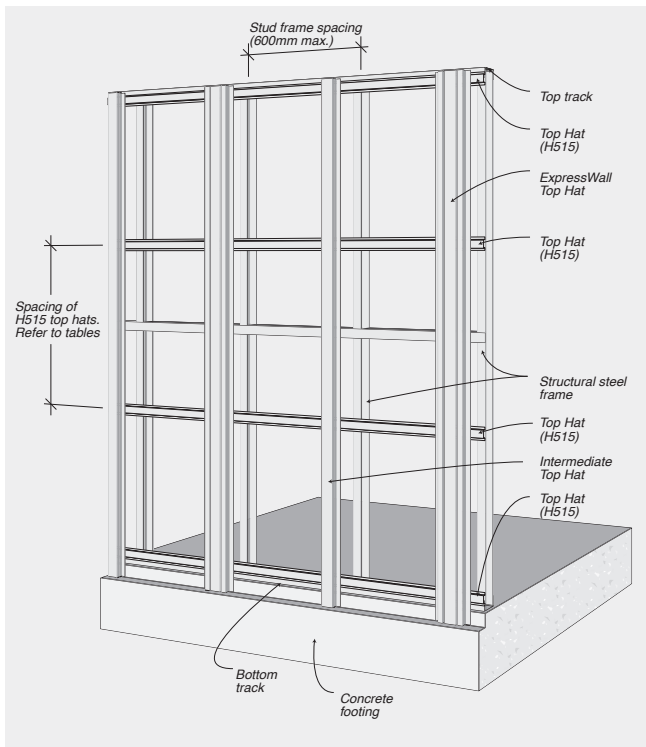
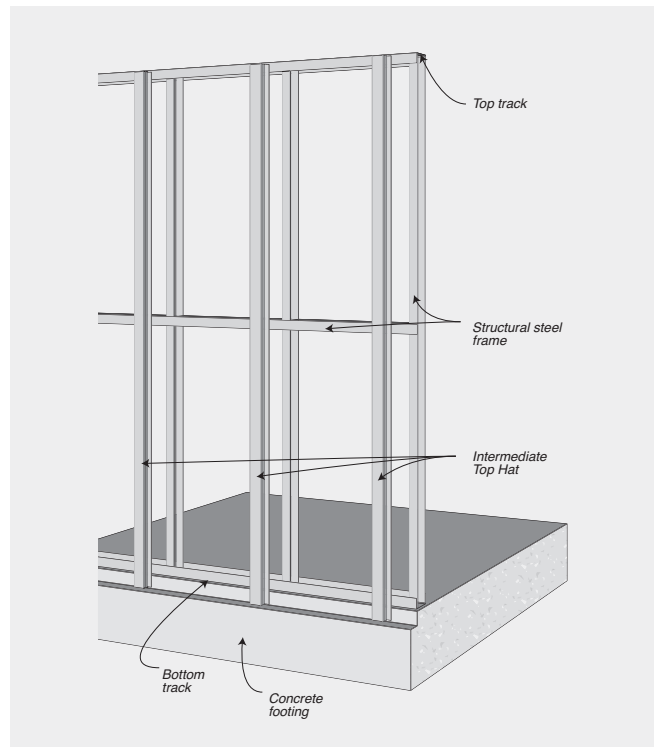


FIGURE 6.10 Over Structural Stud Framing



SYSTEM ENGINEERING



Non-Cyclonic Regions

0.75mm BMT ExpressWall Top Hat Framing System

RESIDENTIAL – AS4055 Compliant – NCC Class 1 and Class 10 Buildings – General & Corner Zones

TABLE 6.01

Wind Classification (AS 4055)	Cladding Support Framing and Fixing Requirements				0.75mm BMT ExpressWall Top Hat Framing System					
	Maximum Spacing of ExpressWall Top Hat Framing System		Maximum Span of Vertical Top Hat (mm)	Maximum Fixing Centres of Cladding (mm)	Maximum Spacing of Horizontal H515 Top Hat (mm)					
	Single Span (mm)	2 or more spans (mm)			Structural Steel Stud Framing System					
			0.75mm BMT Wall Stud Spacing (mm)			1.15mm BMT or Timber Wall Stud Spacing (mm)				
				300	450	600	300	450	600	
General Zones										
N1	600	600	2000	600	1750	1900	1450	2000	1950	1750
N2	600	600	2000	600	1750	1900	1450	2000	1950	1750
N3	500	600	1650	600	1650	1650	1400	1650	1650	1650
N4	500	600	1300	550	1100	1200	900	1300	1250	1100
N5	400	600	1000	450	750	800	600	1000	850	750
N6	400	600	850	350	550	600	450	800	600	550
Corner Zones										
N1	600	600	1650	600	1650	1650	1450	1650	1650	1650
N2	600	600	1500	600	1400	1500	1150	1500	1500	1400
N3	500	600	1100	450	900	950	750	1100	1000	900
N4	400	600	850	350	600	650	500	850	650	600
N5	400	400	900	300	400	450	300	550	450	400
N6	300	400	700	250	300	300	250	400	300	300

Non-Cyclonic Regions and Cyclonic Regions

1.15mm BMT ExpressWall Top Hat Framing System

RESIDENTIAL – AS4055 Compliant – NCC Class 1 and Class 10 Buildings – General & Corner Zones

TABLE 6.02

Wind Classification (AS 4055)	Cladding Support Framing and Fixing Requirements				1.15mm BMT ExpressWall Top Hat Framing System					
	Maximum Spacing of ExpressWall Top Hat Framing System		Maximum Span of Vertical Top Hat (mm)	Maximum Fixing Centres of Cladding (mm)	Maximum Spacing of Horizontal H515 Top Hat (mm)					
	Single Span (mm)	2 or more spans (mm)			Structural Steel Stud Framing System					
			0.75mm BMT Wall Stud Spacing (mm)			1.15mm BMT or Timber Wall Stud Spacing (mm)				
				300	450	600	300	450	600	
General Zones										
N1	600	600	2350	600	1750	1900	1450	2350	1950	1750
N2	600	600	2350	600	1750	1900	1450	2350	1950	1750
N3/C1	500	600	2050	600	1650	1800	1400	2050	1850	1650
N4/C2	500	600	1750	550	1100	1200	900	1600	1250	1100
N5/C3	400	600	1450	450	750	800	600	1100	850	750
N6/C4	400	600	1200	350	550	600	450	800	600	550
Corner Zones										
N1	600	600	1900	600	1750	1900	1450	1900	1900	1750
N2	600	600	1900	600	1400	1500	1150	1900	1550	1400
N3/C1	500	600	1550	450	900	950	750	1300	1000	900
N4/C2	400	600	1250	350	600	650	500	850	650	600
N5/C3	400	400	1250	300	400	450	300	550	450	400
N6/C4	300	400	1050	250	300	300	250	400	300	300



SYSTEM ENGINEERING

Non-Cyclonic Regions

0.75mm BMT ExpressWall Top Hat Framing System

COMMERCIAL – NCC Class 2 to 9 Buildings

TABLE 6.03

Design Ultimate Wind Pressure (kPa)	Cladding Support Framing and Fixing Requirements				0.75mm BMT ExpressWall Top Hat Framing System					
	Maximum Spacing of ExpressWall Top Hat Framing System		Maximum Span of Vertical Top Hat (mm)	Maximum Spacing of Fixings (mm)	Maximum Spacing of Horizontal H515 Top Hat (mm)					
	Single Span (mm)	2 or more spans (mm)			Structural Steel Stud Framing System					
			0.75mm BMT Wall Stud Spacing (mm)			1.15mm BMT or Timber Wall Stud Spacing (mm)				
				300	450	600	300	450	600	
1	600	600	1700	600	1700	1700	1450	1700	1700	1700
1.5	500	600	1350	600	1150	1250	950	1350	1300	1150
2	500	600	1100	450	850	950	700	1100	950	850
2.5	400	500	1150	450	700	750	550	1000	750	700
3	400	500	1000	350	550	600	450	800	650	550
3.5	400	400	1000	300	500	500	400	700	550	500
4	400	400	900	300	400	450	350	600	450	400
4.5	300	400	850	300	350	400	300	550	400	350
5	300	400	800	300	350	350	250	500	350	350
5.5	300	400	750	250	300	300	250	450	350	300
6	300	400	700	250	250	300	200	400	300	250
6.5	300	400	650	200	250	250	200	350	300	250
7	300	400	600	200	250	250	200	350	250	250

Non-Cyclonic Regions and Cyclonic Regions

1.15mm BMT ExpressWall Top Hat Framing System

COMMERCIAL – NCC Class 2 to 9 Buildings

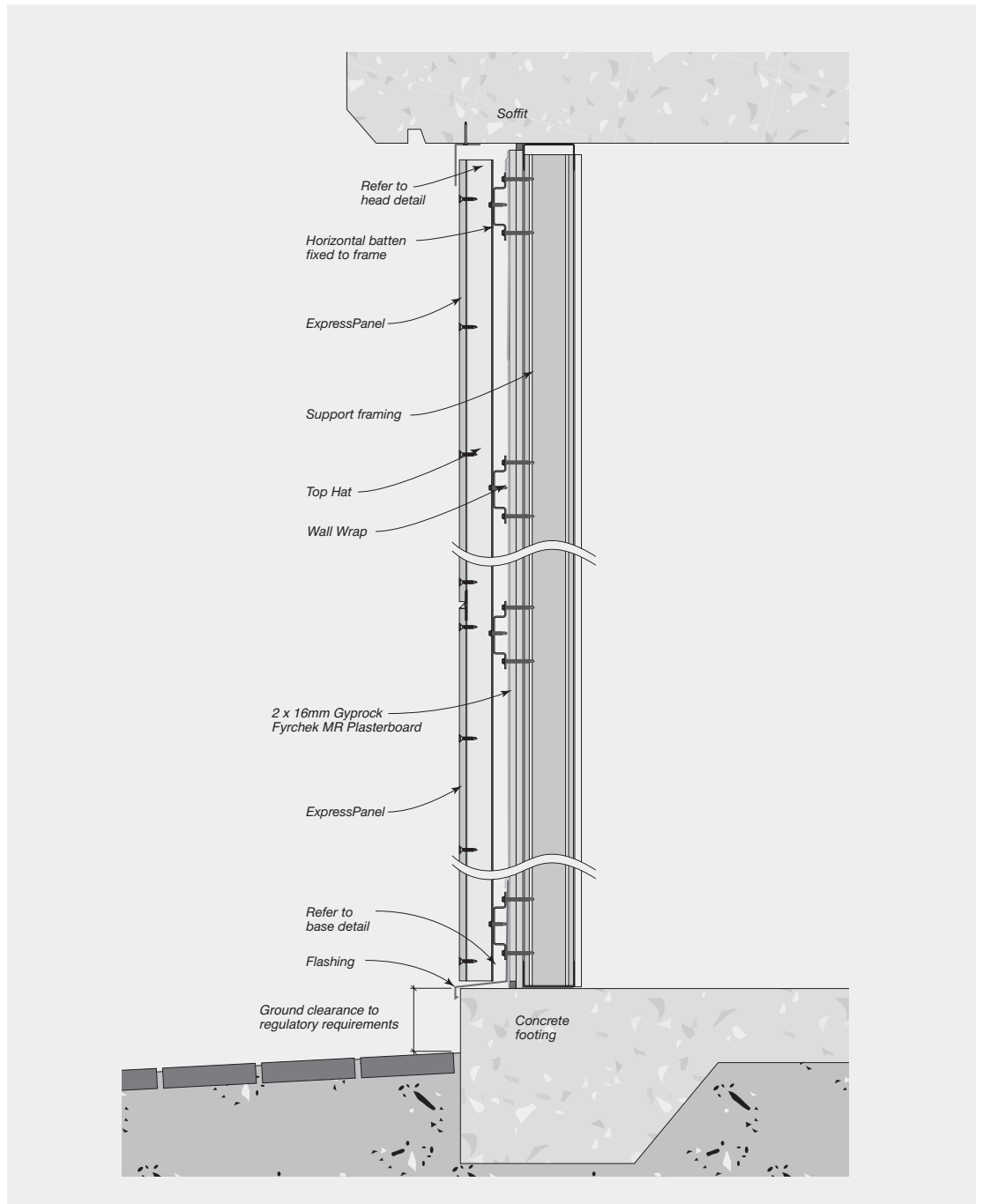
TABLE 6.04

Design Ultimate Wind Pressure (kPa)	Cladding Support Framing and Fixing Requirements				1.15mm BMT ExpressWall Top Hat Framing System					
	Maximum Spacing of ExpressWall Top Hat Framing System		Maximum Span of Vertical Top Hat (mm)	Maximum Fixing Centres of Cladding (mm)	Maximum Spacing of Horizontal H515 Top Hat (mm)					
	Single Span (mm)	2 or more spans (mm)			Structural Steel Stud Framing System					
			0.75mm BMT Wall Stud Spacing (mm)			1.15mm BMT or Timber Wall Stud Spacing (mm)				
				300	450	600	300	450	600	
1	600	600	1950	600	1750	1900	1450	1950	1950	1750
1.5	500	600	1700	600	1150	1250	950	1650	1300	1150
2	500	600	1550	450	850	950	700	1250	950	850
2.5	400	500	1600	450	700	750	550	1000	750	700
3	400	500	1450	350	550	600	450	800	650	550
3.5	400	400	1400	300	500	500	400	700	550	500
4	400	400	1300	300	400	450	350	600	450	400
4.5	300	400	1200	300	350	400	300	550	400	350
5	300	400	1150	300	350	350	250	500	350	350
5.5	300	400	1100	250	300	300	250	450	350	300
6	300	400	1000	250	250	300	200	400	300	250
6.5	300	400	950	200	250	250	200	350	300	250
7	300	400	950	200	250	250	200	350	250	250

SYSTEM ENGINEERING



FIGURE 6.11 Typical Commercial ExpressPanel External Fire Rated Installation. Pressure Equalised Ventilated Cavity System



07

INSTALLATION



Check quality and quantity of panels and components before installing. If there is any sign of damage or visible defects in panels, or the finish is not in keeping with the owner's aesthetic requirements DO NOT INSTALL. Contact Cemintel to address any issues.

CHECKLIST – Prior to Installation

The following pre-install checklist may assist to ensure you have the best possible outcome when using Commercial ExpressPanel.

- Ensure substrate is straight and plumb. Pack studs to straighten if necessary (timber frames as per AS 1684, steel frames as per AS/NZS 4600). Industry best practice for frame tolerance is 5mm misalignment over 3000mm.
- Ensure studs are correctly located and of the appropriate thickness.
- Confirm bracing is in place. Where sheet bracing is used behind panels, the entire wall area needs to be braced or bracing sheet packers fixed to the frame to ensure a uniform fixing plane.
- Remove any concrete that may foul the cladding line, particularly at steps in slabs and isolated columns.
- Ensure there is adequate ground clearance to the bottom edge of the Commercial ExpressPanels as per regulatory requirements (including for water/ rain runoff and termite management). These can vary from 50-150mm depending on type of ground and termite requirements.
- Confirm your panel layout to determine the location of joints and identify where additional studs are required.
- Flashings, membranes and air barrier should be correctly installed, overlapped and taped at joints, prior to fixing panels.
- Install windows so that the back of the front face of the window (or any other protrusions including doors or meter boxes) will be flush with the face of the panels.
- Fit Head flashings over windows, doors and other penetrations.
- Confirm the chosen eaves/soffit details and prepare accordingly.
- Consider the need for structural support for fixtures such as pergolas and balconies. No loads may be carried by the cladding.
- Confirm membranes and flashings for balcony areas have been installed in accordance with manufacturers' specifications.
- Arrange for a pre-cladding inspection by the appropriate local building authority if required.



07

INSTALLATION

Installation Set-Out

Appropriate panel fixing layout and top hat spacing should be suitable for the project design wind pressure. It is recommended that fasteners be fixed

100mm from the top and bottom edges of the panel and 40mm in from the side of the panels.

FIGURE 7.01 Horizontal Sheet Fixing

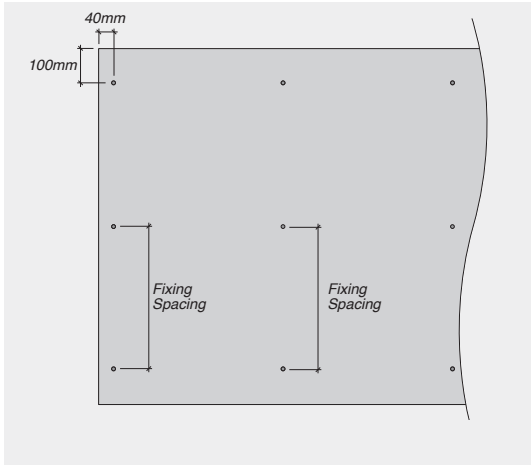
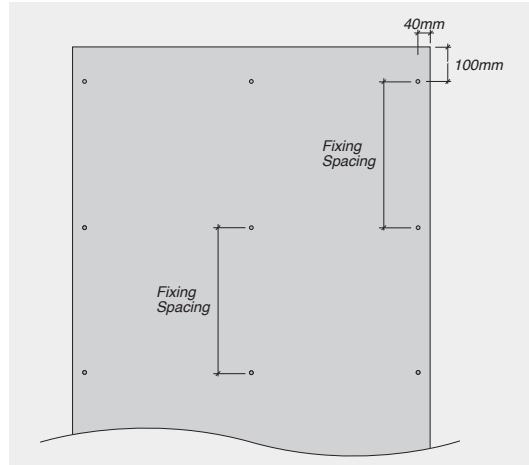


FIGURE 7.02 Vertical Sheet Fixing



Panels must be fixed in accordance with the tables set out in 'System Engineering' section. This provides fixing Requirements and Maximum Top Hat Spacings for 1200mm wide panels based on 2 top hats or 3 or more top hats.

Installation for Timber and Steel Framing

Refer to 'System Engineering' and 'Construction Drawings and Details' sections for specific fixing information.

Step 1 – Install air barrier – as per Cemintel Rigid Air Barrier Design & Installation Guide or soft air barrier as per details in this guide.

Step 2 – Fix base flashing to base of wall over air barrier (wall wrap or rigid air barrier) taping top edge of flashing to air barrier.

Step 3 – Fix cavity baffle and top hats. Fix cavity baffle to suit cavity depth at major corners nominated by the project designer. Fix H515 top hats horizontally where required to substrate as per 'System Engineering' section requirements. Fix ExpressWall and intermediate top hats vertically to H515 framing as per 'System Engineering' section requirements.

Step 4 – Prepare panels. Cut panels as required. Run a fine sandpaper block along the edge of the cut panel (taking care not to scratch the panels surface). Seal cut edges with Cemintel's recommended edge sealant to protect against moisture entering the panels.

Step 5 – Pre-drill panel holes. This should be done prior to lifting panels into place and can be done off site. Panel holes need to be drilled a minimum 100mm from the horizontal edge and a minimum of 40mm from the vertical edge (refer to 'System Engineering Section').

Use the recommended countersinking tool for countersunk head screws, and a 6mm masonry bit for exposed head screws (Refer Fig. 7.03). Holes must be 6.0mm to 6.5mm in diameter. Dust must be cleaned out of holes.

If using exposed head screws or rivets with offsite pre-drilled and pre-painted ExpressPanel, refer to Cemintel Barestone External Design and Installation Guide.

FIGURE 7.03 Countersinking Tool – Screw Fix

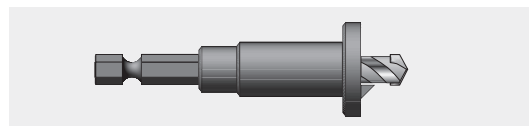
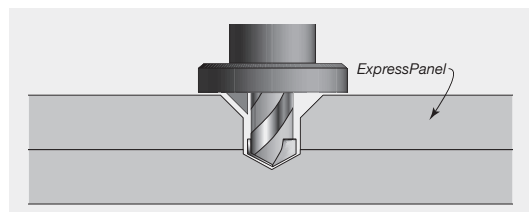


FIGURE 7.04 Pre-drilling Panels – Countersunk Screw Fix



INSTALLATION



Note: Use only the recommended tool as supplied by CSR. The use of other tools for this purpose may reduce fixing capacity or reduce the weather resistance of the system.

DO NOT use hammering action when drilling. For efficiency you can neatly stack 3 or 4 sheets and drill through all at the same time. Take care to avoid damaging the panel with the drill chuck when approaching the end of the hole by using a timber block.

HINT: One way of drilling holes is to drill the top sheet of a pack with the counter sinking drill set to approximately 12mm depth. (Refer Fig. 7.04) This will give a starter hole on the sheet below, saving on set out time.

Clean/sweep away any dust from holes as this can stick to the panel.

Step 6 – Install Vertical gaskets to the ExpressWall Top Hats for the full extent of panels. Take care not to stretch the gasket when installing. (Refer Fig. 7.05) When joining gasket, cut ends cleanly and push together before adhering. When top hat is discontinuous, butt ends together tightly and continue gasket over the joint. If a gap is present, install a steel strip to support the gasket. (Refer Fig. 7.06)

At the beginning and end of a vertical joint, such as with sheets installed in a half-bond pattern, continue the vertical gasket past the horizontal joint by 100mm minimum. (Refer Fig. 7.07)

FIGURE 7.07 Vertical Gasket and Fixing Detail for Half-Bond Panel Layout – Screw Fixed

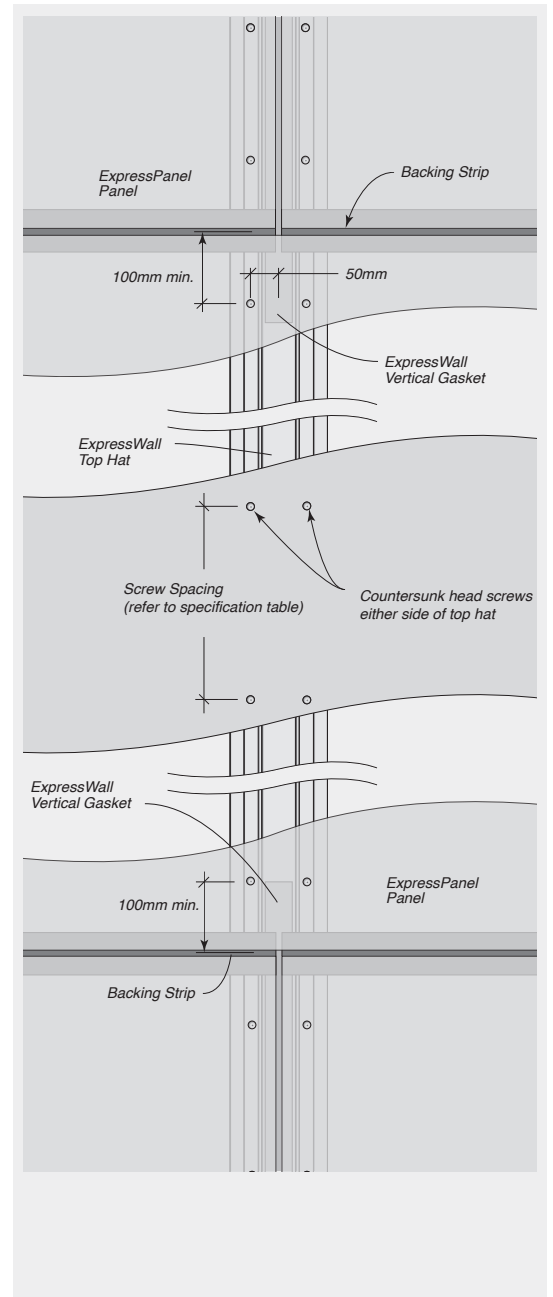


FIGURE 7.05 Vertical Gasket – Screw Fixed

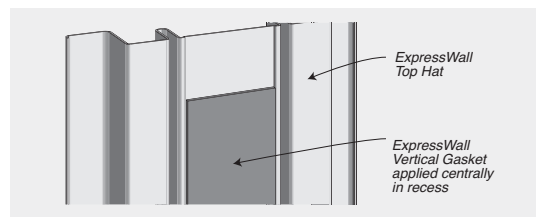
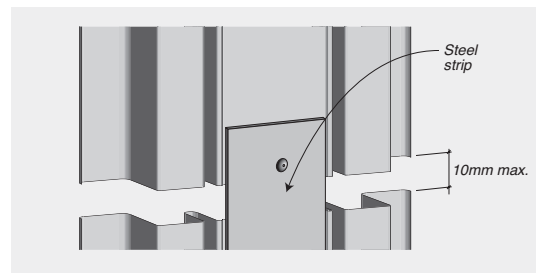


FIGURE 7.06 Gasket Support at Discontinuous Joint – Screw Fixed



07

INSTALLATION

Step 7 – Install wall panels.

When fixing panel using countersunk screws, lift panel into place, clamp down level to identify horizontal and vertical planes.

When using the ExpressWall Backing Strip, ensure ExpressWall Backing Strip is 6mm shorter overall than the width of the panel (cut to length if necessary). (Refer Fig. 7.08)

Cemintel recommends the use of a screw gun with torque control to prevent overdriving of screws. Countersunk head screws can be used with 1.15BMT Top Hats – care should be taken when fixing screws to 0.75BMT ExpressWall Top Hats as screws can strip in the lighter gauge. (Refer Fig. 7.11)

Fix panel starting at the bottom corner. Push the panel firmly against the framing/gaskets and screw through panel hole into the top hat with the countersunk head screw.

Before fixing top countersunk head screws to panel, insert ExpressWall Backing Strip along horizontal joint. Clip corners at an angle and bend. Commercial ExpressPanels are generally installed with a nominal 8-10mm wide expressed joint in both horizontal and vertical directions (a small cut piece of panel can be used as a spacer to easily measure joint widths and ensure consistency). Once positioned, fasten top row of countersunk head screws.

To seal the groove in the backing strip at the ends, apply a small section of gasket to the rear of the backing strip. This will be forced into the recess and seal the end of the strip. Alternatively use Sikaflex 11FC to fill the groove. (Refer Fig. 7.10)

A fillet of Sikaflex 11FC is then placed along the top edge of the panel. This ensures that the joint drains and salt and dirt do not build up in the joint. (Refer Fig. 7.09, 7.10 & 7.12)

When fixing panel using exposed head screws, install the ExpressWall Weather Seal into the pre-drilled hole in the panel. Drive the exposed head screw through the weather seal and into the top hat using an electric screw gun. For further information, refer to Cemintel Barestone External Design and Installation Guide.

Joint widths – While panels are generally installed with a nominal 8-10mm wide horizontal and vertical expressed joint. However joints up to 20mm can be formed provided additional care is taken during installation to ensure that panel edges cover the joint gaskets by a minimum of 10mm.

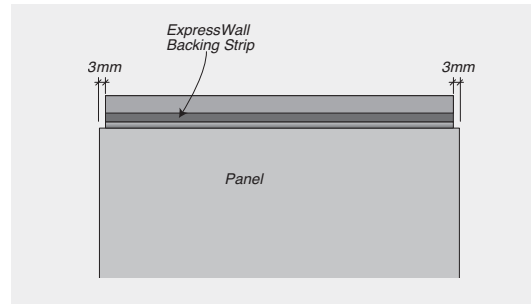
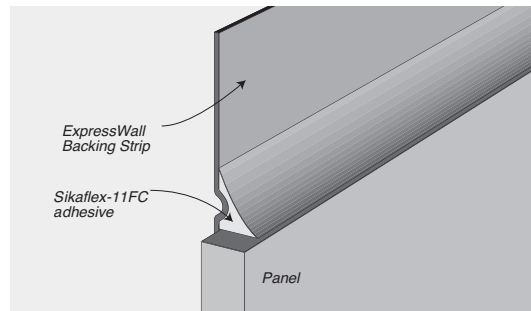
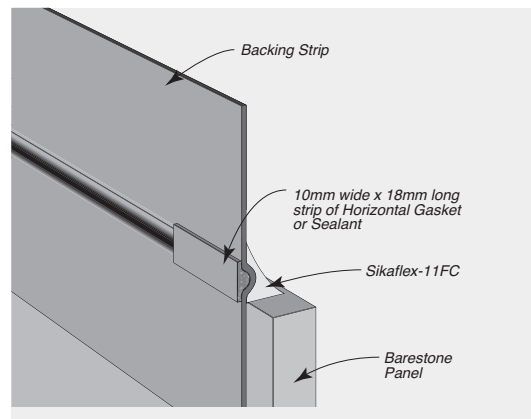
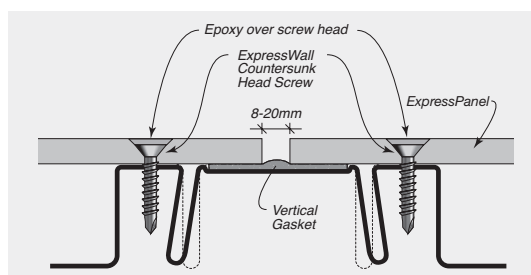
FIGURE 7.08 ExpressWall Backing Strip Positioning**FIGURE 7.09** Horizontal Joint with ExpressWall Backing Strip**FIGURE 7.10** Sealing Ends of ExpressWall Backing Strip**FIGURE 7.11** Vertical Joint – Countersunk Screw

FIGURE 7.12 Horizontal Joint Detail with ExpressWall Backing Strip – Sealant Filled and Screw Fixed

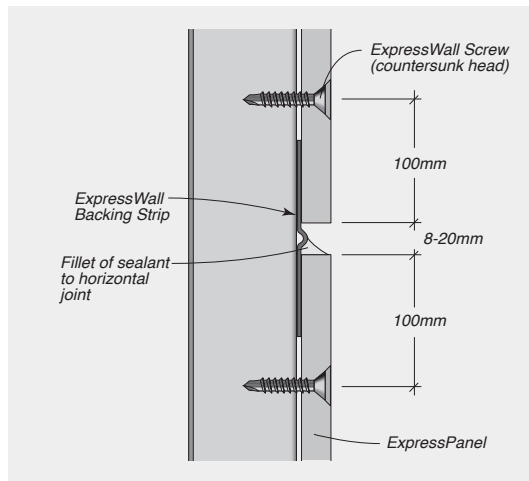
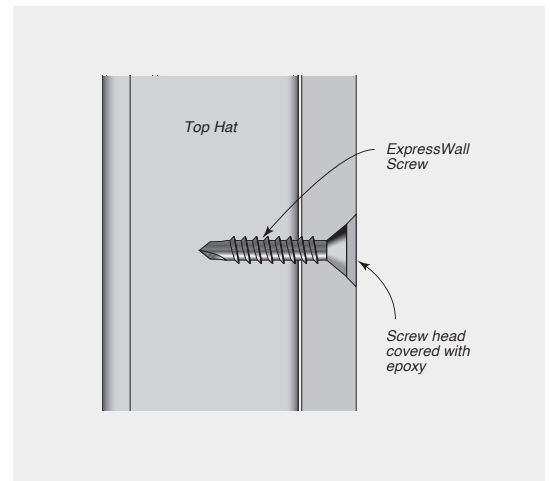


FIGURE 7.13 Countersunk screw head



Screw Head Covering for Countersunk screws

All countersunk head screws must be covered with epoxy compound and flush finished with the face of the panel. (Refer Fig. 7.13) The epoxy shall be installed in the following manner:

- Deburr edges of the countersunk screw hole and clean of any dust using compressed air.
- Mix Megapoxy P1 accurately in accordance with the packaging/manufacturer's instructions. In colder climates, eg. Tasmania, use Megapoxy PF. Only mix sufficient epoxy for area of panels being worked on and immediately use mixed epoxy.
- Apply epoxy 1 to 2mm thick to cover the screw head. Do not completely fill the hole with epoxy and ensure care is taken to avoid spreading of epoxy over the panel surface. Clean any excess epoxy immediately otherwise it will set.
- Allow epoxy sufficient time to fully cure and harden in accordance with the manufacturer's recommendations.
- Fill the remainder of the countersunk screw hole with Polyfilla Pro Deep and Large Cracks, using a steel spatula to achieve a flush finish with the face of the panel. Allow appropriate setting time as per manufacturer's instructions.
- Should shrinkage of the initial application of Polyfilla Pro Deep and Large Cracks occur, apply additional Polyfilla Pro Deep and Large Cracks as required.
- The surface should be reasonably smooth with no sanding required. Should sanding be required, lightly sand back Polyfilla Pro with fine grit sandpaper ensuring care is taken to minimise damage to the surface of the panel. Remove any dust prior to applying any finish to the panel.
- Apply compatible surface coatings to the panel in accordance with manufacturer's instructions. **Note:** additional surface penetration may be required to minimise show-through of filled countersunk screw holes.

07

INSTALLATION

In certain conditions such as corrosive environments or where there is a preference to have flush sealed joints, horizontal and vertical joints may be filled with recommended joint sealant and in accordance with manufacturer's instructions. Base of walls including horizontal joints at inter-storey junctions must

remain open, to allow pressure equalisation to be maintained and for any water moisture to drain from the cavity. Refer to the sealant filled joint details of the "Construction Drawings and Details" section of this manual.

FIGURE 7.14 Joint Construction - Sealed Option

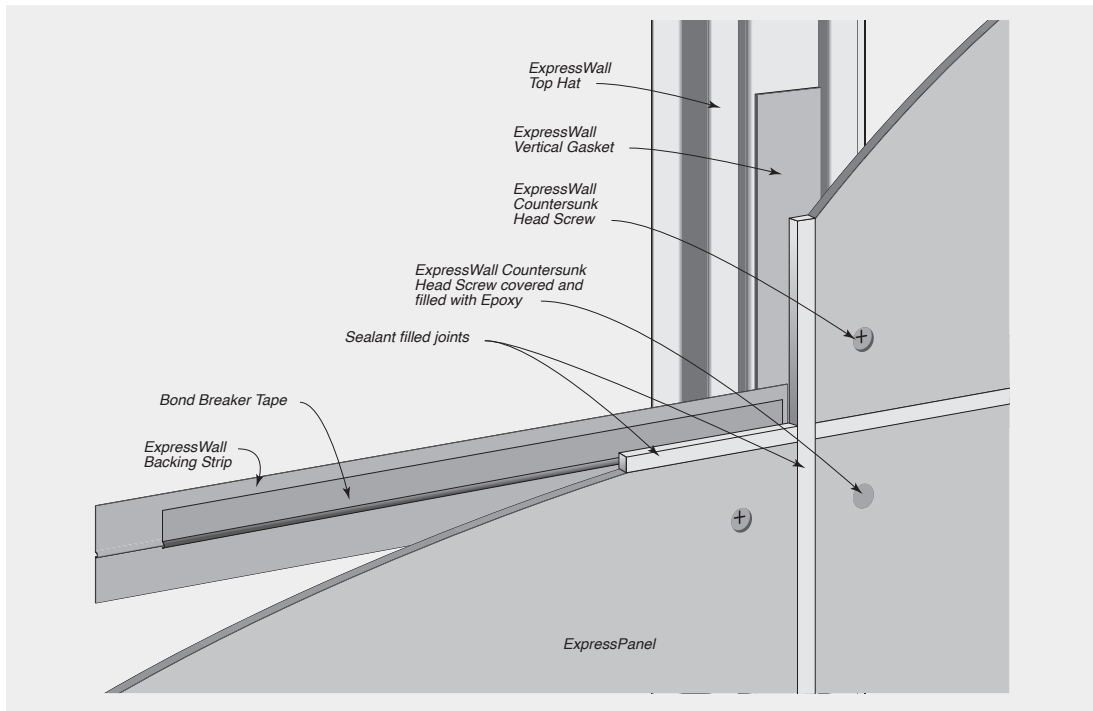


FIGURE 7.15 Horizontal Joint Sealed Side

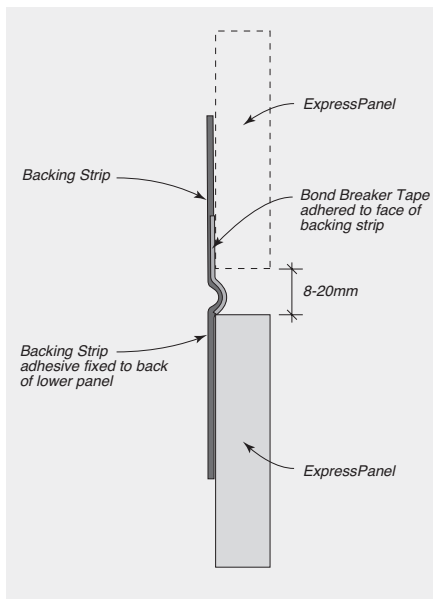


FIGURE 7.16 Horizontal Joint Sealed Side

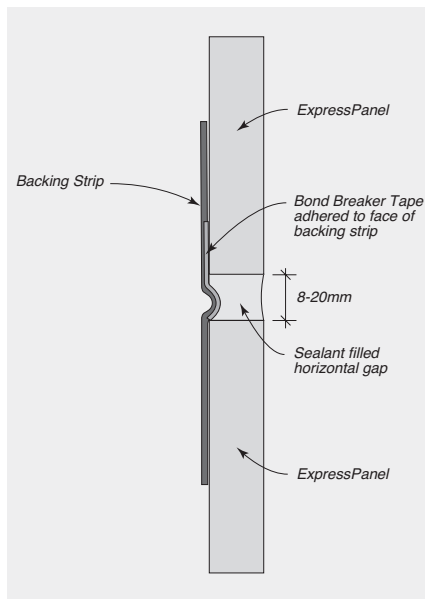


FIGURE 7.17 Backing Strip & Bond Breaker Tape

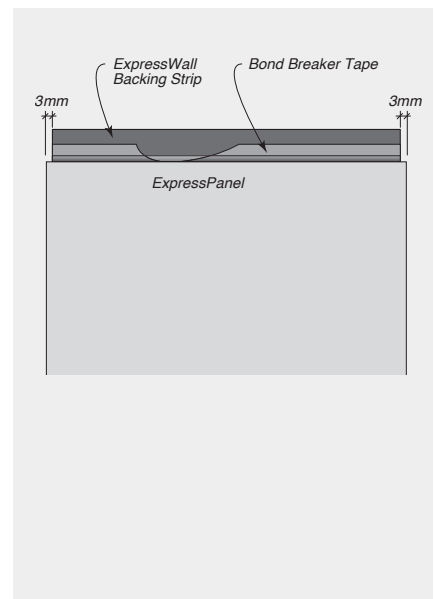


FIGURE 7.18 Horizontal Joint Fixing – Sealed Option

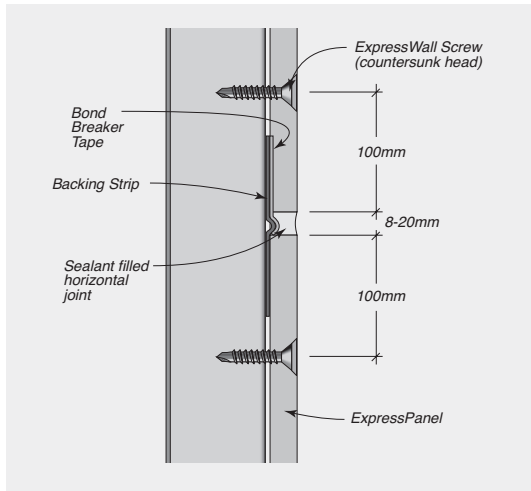
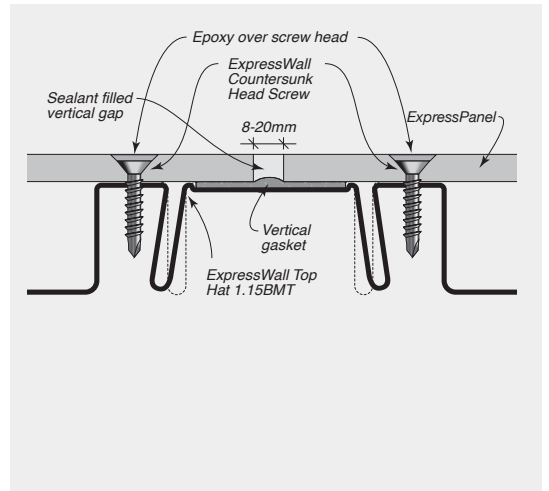


FIGURE 7.19 Vertical Joint – Sealed Option



07

INSTALLATION

Installation of Cemintel Rigid Air Barrier™

The Cemintel Rigid Air Barrier may be installed horizontally or vertically across the frame. An appropriate panel fixing layout should be selected for the project design wind pressure and frame spacing. Panels must be fixed in accordance with the tables set out in the 'System Engineering' Section.

Panels are fixed to timber framing using nails to

steel framing using screws. A small joint (maximum 3mm) is acceptable. Joints are taped using HighTack tape to form an air barrier. Similarly, all corners, penetrations and junctions are sealed with HighTack tape or with flexible sealant.

All flashings should be fixed over the top of the Rigid Air Barrier and taped with HighTack tape.

Procedure for Horizontal or Vertical Sheet Application

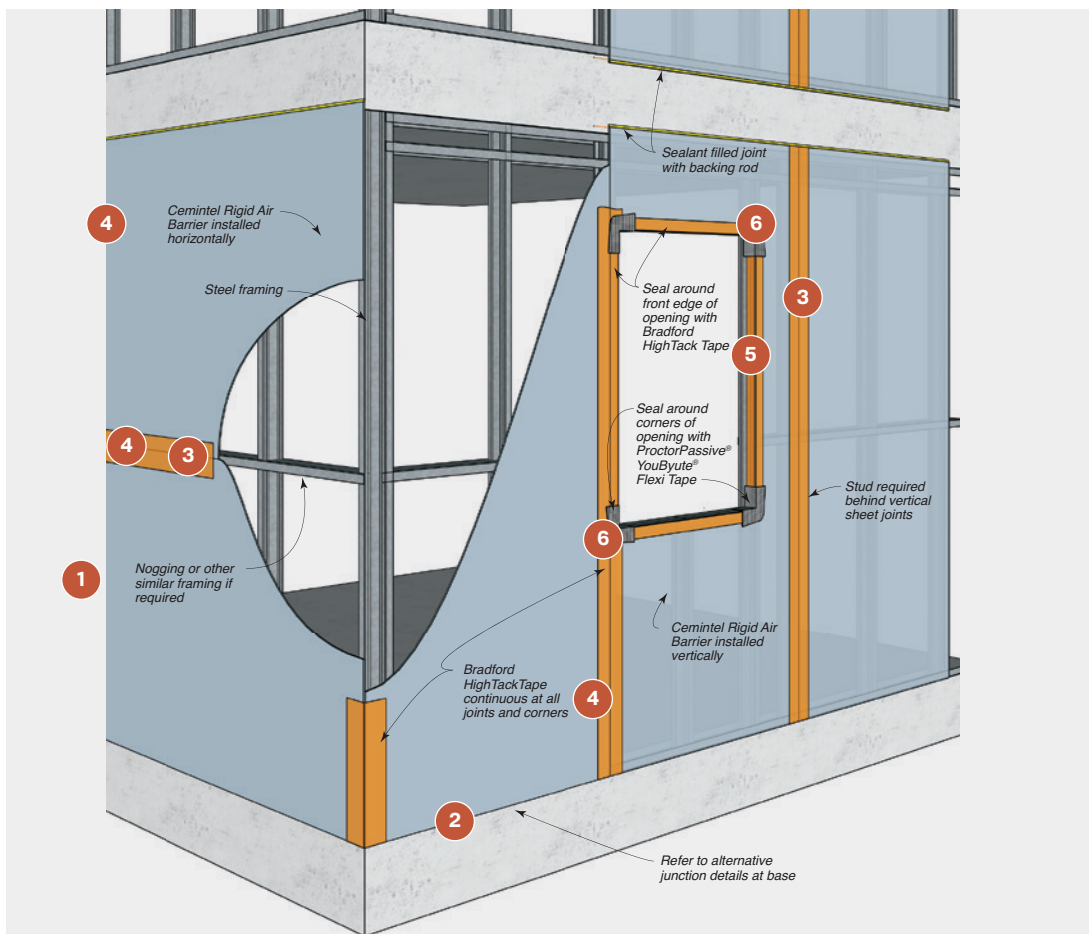
- 1 Cut sheets to ensure vertical joints are supported by studs and horizontal joints are backed by noggings.
- 2 Position sheets (refer to Head & Base details in 'Construction Details' section). Screw fix (to steel frame) or nail (to timber frame) at the detailed fastener centres.
- 3 Install adjacent sheets.
- 4 Seal vertical joints, horizontal joints, and corners with ProctorWrap™ HighTack tape. Seal junctions and penetrations with Sikaflex Pro flexible sealant.
- 5 Seal any openings in head, sill and jamb framing with ProctorWrap™ HighTack tape.
- 6 Install ProctorPassive® YouByute® Flexi Tape to corners of windows and openings to seal all gaps and protect framing. Roll the tape onto the surface to ensure tape is not overstretched, and apply with pressure using a roller or squeegee. Taped surface to extend back beyond the sealant line of the window framing.

The substrate should be dry, free of loose material (dirt or dust) and surfactants, tensides, release agents like grease or oil, and prepared in accordance with install guidance for the ProctorPassive® YouByute® Flexi Tape.



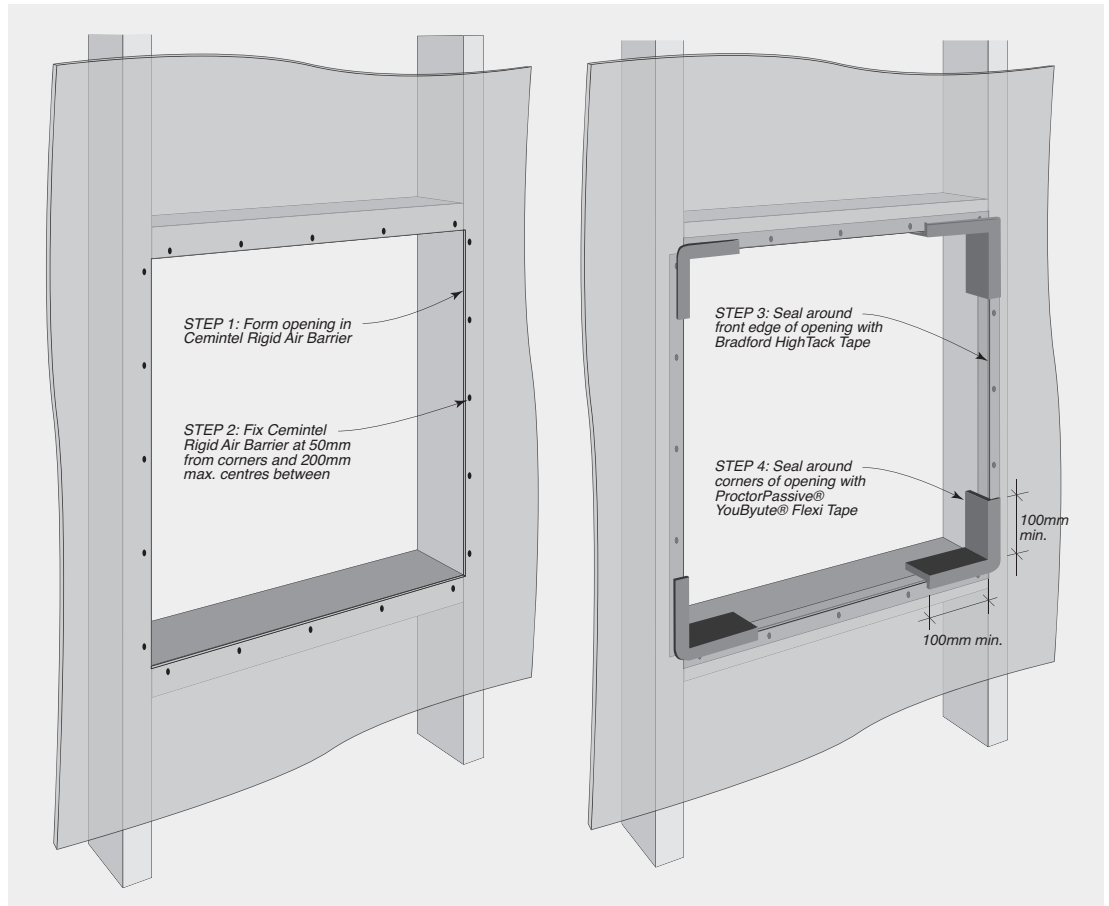
Check quality and quantity of panels and components before installing. If there is any sign of damage or visible defects in panels DO NOT INSTALL. Contact Cemintel to address any issues.

FIGURE 7.20 Typical Rigid Air Barrier Installation



INSTALLATION

07

FIGURE 7.21 Treatment at Window/Door Openings - Rigid Air Barrier

07

INSTALLATION

Installation of Soft Air Barriers

Wall wraps intended to be used as air barriers are fixed to timber or steel framing. Enviroseal™ CW-IT has an inbuilt adhesive strip which allows fast, consistent and reliable sealing to adjoining rolls of CW-IT.

At internal corners, penetrations and perimeters of areas with wall wrap, a metal strip is required to

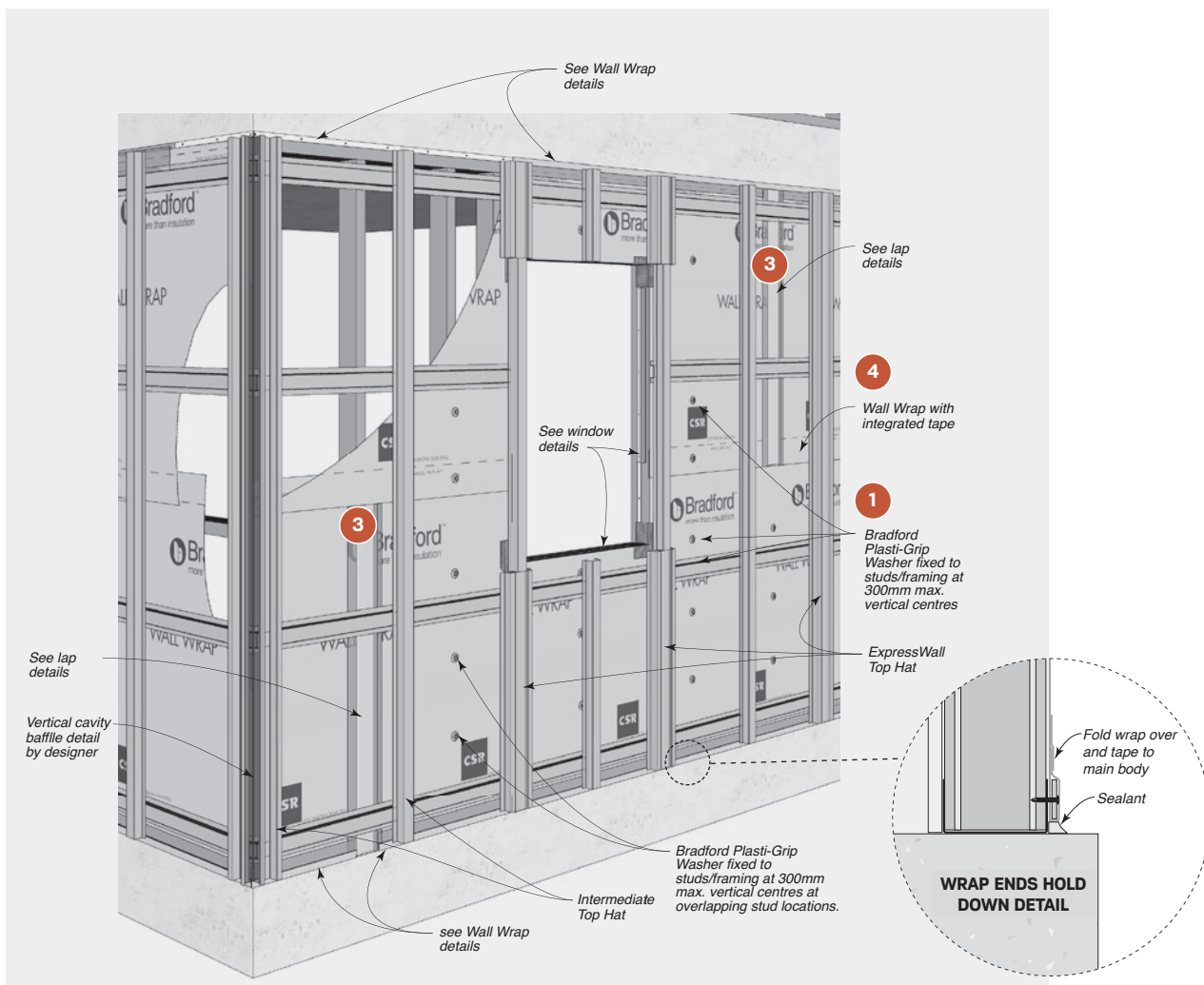
restrain the wall wrap edges. The wall wrap is then folded over and taped to the main body wrap with HighTack Tape. As detailed, sealant or tape is to be applied to maintain an effective air seal.

All flashings should be fixed over the top of the wall wrap and taped.

Procedure for installation of Soft Air Barriers

- 1 Install wall wrap to outside face of timber or steel wall framing using Bradford Plasti-Grip Washers. Horizontal laps must be overlapped by 150mm.
- 2 Install minimum 20mm x 1.6mm aluminium strips horizontally at head and base of wall. Pass wall wrap under aluminium strip and fix strip at 100mm max. cts. Then fold wall wrap back over strip and tape with HighTack tape to main body.

FIGURE 7.22 Typical Soft Air Barrier Installation

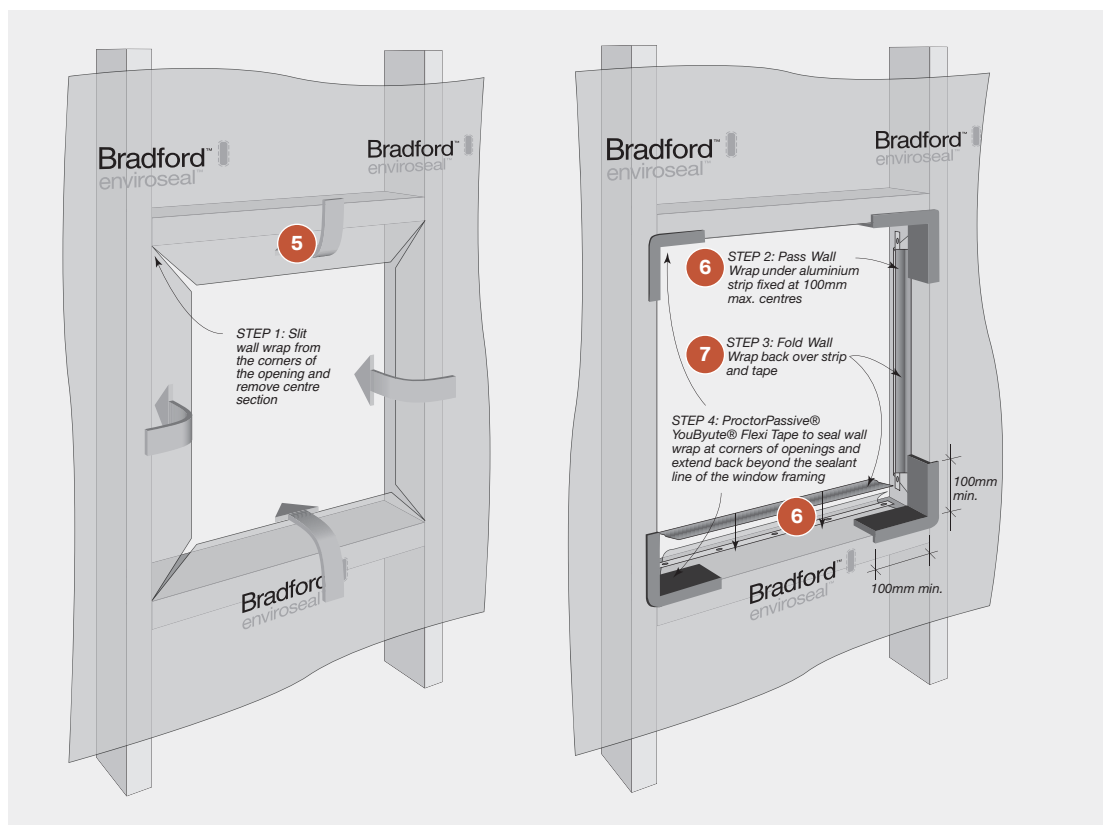


INSTALLATION

07

- 3 Install aluminium strips at vertical joints/ends/corners (where required). Pass wall wrap under aluminium strip and fix at 100mm max cts. Fold wall wrap back over strip and tape with HighTack tape to main body.
- 4 Enviroseal™ CW-IT to be overlapped at horizontal joints and taped continuously with in-built adhesive strip. Vertical lap joints to be overlapped across adjoining studs, fixed with Bradford Plasti-Grip Washers, aluminium strips and taped with HighTack tape along overlap joint. (Refer to Table 4.03).
- 5 At openings, cut the wrap at 45 degrees from each corner to the centre.
- 6 Pass wall wrap under aluminium strip and fix at 100mm max. cts. Then fold wall wrap back over strip and tape with HighTack tape, cutting away any excess wall wrap.
- 7 Install ProctorPassive® YouByute® Flexi Tape to corners of windows and openings to seal all gaps and protect framing. Roll the tape onto the surfaceto ensure tape is not overstretched, and apply with pressure using a roller or squeegee to ensure a strong bond. Taped surface to extend back beyond the sealant line of the window framing.

FIGURE 7.23 Treatment at Window/Door Openings – Soft Air Barrier





CONSTRUCTION
DRAWINGS + DETAILS

CONSTRUCTION DRAWINGS AND DETAILS



Note: Drawings are interchangeable for timber or steel substrates with the exception of the fasteners.

Drawings Index

SECTION	DESCRIPTION	FIGURE REFERENCE	PAGE NUMBER	
VENTILATED CAVITY SYSTEM				
Overview	Joint Construction – Ventilated Cavity System	8.01	49	
Joint Details	10mm Horizontal Joint – Sealant Filled	8.02	49	
	Horizontal Joint – Angled Backing Strip	8.03	49	
	Vertical Joint – Exposed Head Screw	8.04	49	
Cross Section Details	Typical ExpressWall System Cross Section for Steel Framing	8.05	50	
Head Details	Eaves/Deflection Head – Ventilated	8.06	50	
Base Details	Base Detail – Drained	8.07	50	
	External Corner	8.08	51	
Corner Details	External Corner – Obtuse Angle	8.09	51	
	Internal Corner Detail	8.10	51	
	Framed Soffit	8.11	52	
Junction Details	Control Joint – Vertical	8.12	52	
	Inter-Storey Junction with Flashing	8.13	52	
	Inter-Storey Junction with Flashing	8.14	52	
	Abutment	8.15	53	
	Vertical Gasket and Fixing Detail for Half-bond Panel Layout	8.16	53	
Window Details	Typical Window Installation	8.17	53	
Parapet Capping	Parapet Capping	8.18	54	
Balcony Details	Balcony Base	8.19	54	
Drain	Typical Drain	8.20	54	
Power/Meter Box Details	Typical Power/Meter Box	8.21	55	
VENTILATED CAVITY SYSTEM – SEALANT FILLED JOINT DETAILS				
Overview	Sealant Filled Joint Construction – Ventilated Cavity System	8.22	56	
	Backing Strip Preparation	8.23	56	
Joint Details – Sealant filled	Horizontal Joint – Sealant filled	8.24	56	
	Vertical Joint – Sealant filled	8.25	56	
Cross Section Details – Sealant filled	Typical ExpressWall System Cross Section for Steel Framing – Joints sealant filled	8.26	57	
Head Detail – Sealant filled	Eaves/Deflection Head – Sealant filled	8.27	57	
Base Detail – Drained	Base Detail – Drained	8.28	57	
Corner Details – Sealant filled	Internal Corner Detail – Sealant filled	8.29	58	
	External Corner – Sealant filled	8.30	58	
SOFT AIR BARRIER				
Overview	Typical Installation Overview - Soft Air Barrier	8.31	59	
Corner Details	External Corner – Wall Wrap Continuous	8.32	60	
	External Corner – Wall Wrap Overlapped	8.33	60	
	Internal Corner – Wall Wrap Continuous	8.34	60	
	Internal Corner – Wall Wrap Overlapped	8.35	60	
	Abutment to Concrete or Masonry Wall	8.36	60	
Junction Details	Wall Wrap Installation to Wall, Soffit and Base	8.37	61	
	Wall Wrap Installation at Intermediate Level Junction – Non-loadbearing Steel Framing With Deflection Head	8.38	61	
	Vertical Wall Wrap Junction – Overlapped Double Strip Join	8.39	62	
	Vertical Wall Wrap Junction – Overlapped Single Strip Join	8.40	62	
	Vertical Wall Wrap Junction – At Control Joint	8.41	62	
	Vertical Wall Wrap Junction – No Lap double Washer	8.42	62	
	Window Details	Wall Wrap Installation at Window/Door Opening	8.43	63
	Junction Details	Wall Wrap Installation at Drain Penetration – Timber or Steel Framing	8.44	63
		Wall Wrap Installation at Parapet Junction – Timber or Steel Framing	8.45	64



CONSTRUCTION DRAWINGS AND DETAILS

Note: Drawings are interchangeable for timber or steel substrates with the exception of the fasteners.

Ventilated Cavity System

FIGURE 8.01 Joint Construction – Ventilated Cavity System

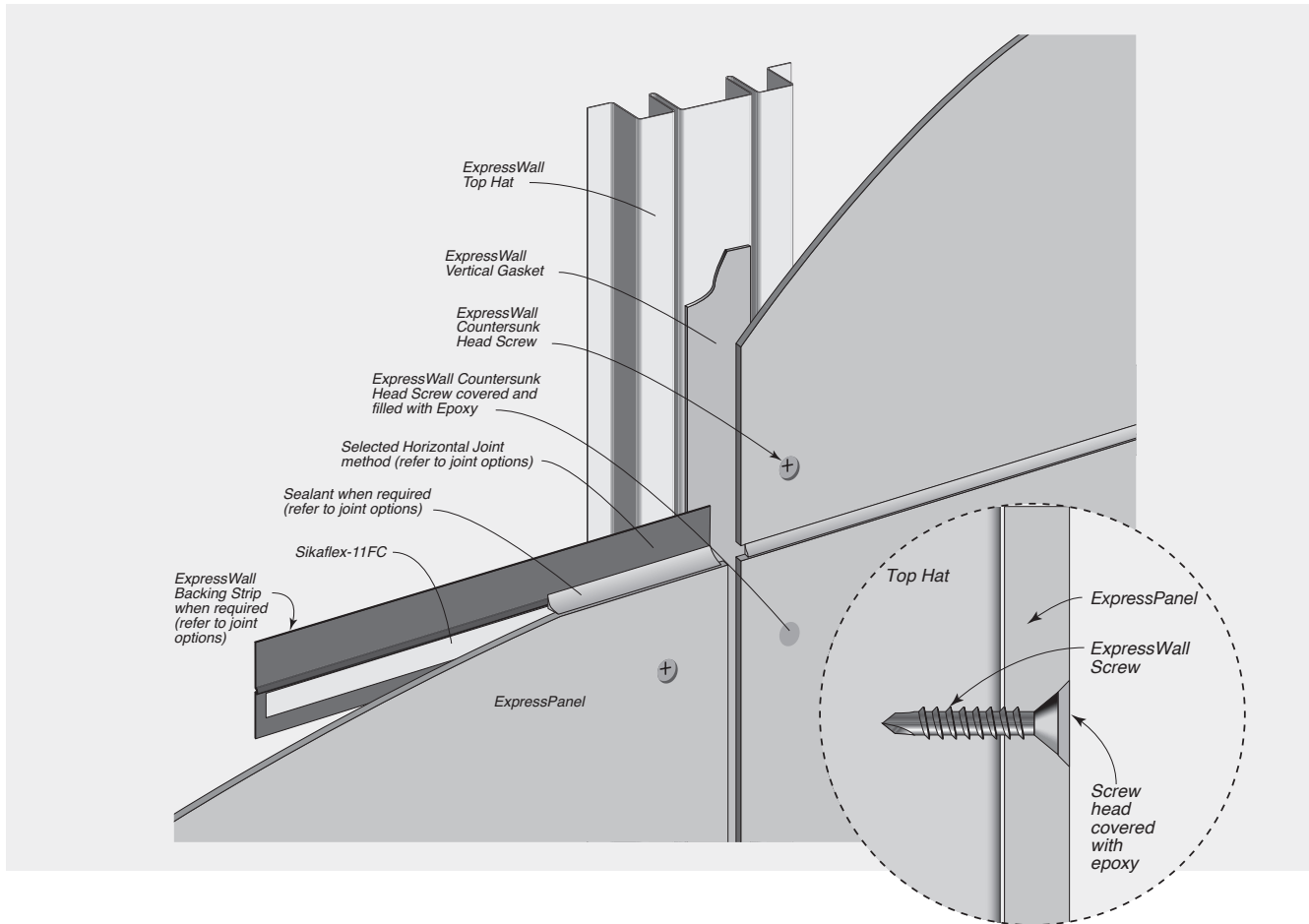


FIGURE 8.02 10mm Horizontal Joint – Sealant Filled

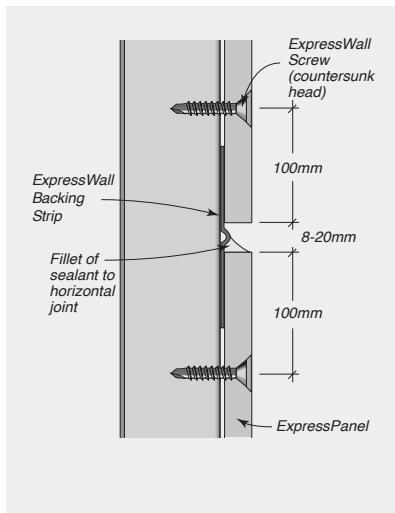


FIGURE 8.03 Horizontal Joint – Angled Backing Strip

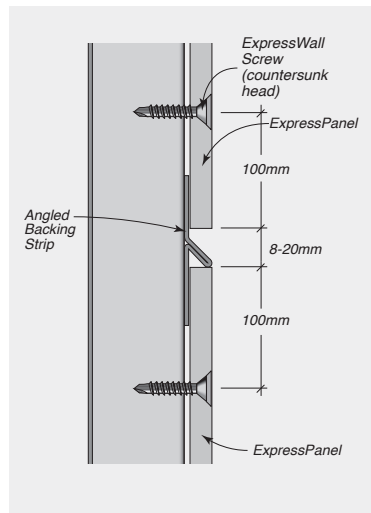
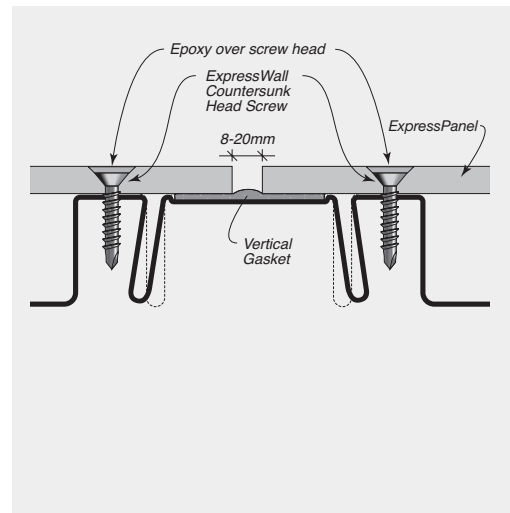


FIGURE 8.04 Vertical Joint – Exposed Head Screw



CONSTRUCTION DRAWINGS AND DETAILS



Note: Drawings are interchangeable for timber or steel substrates with the exception of the fasteners.

Ventilated Cavity System

FIGURE 8.05 Typical ExpressWall System Cross Section for Steel Framing

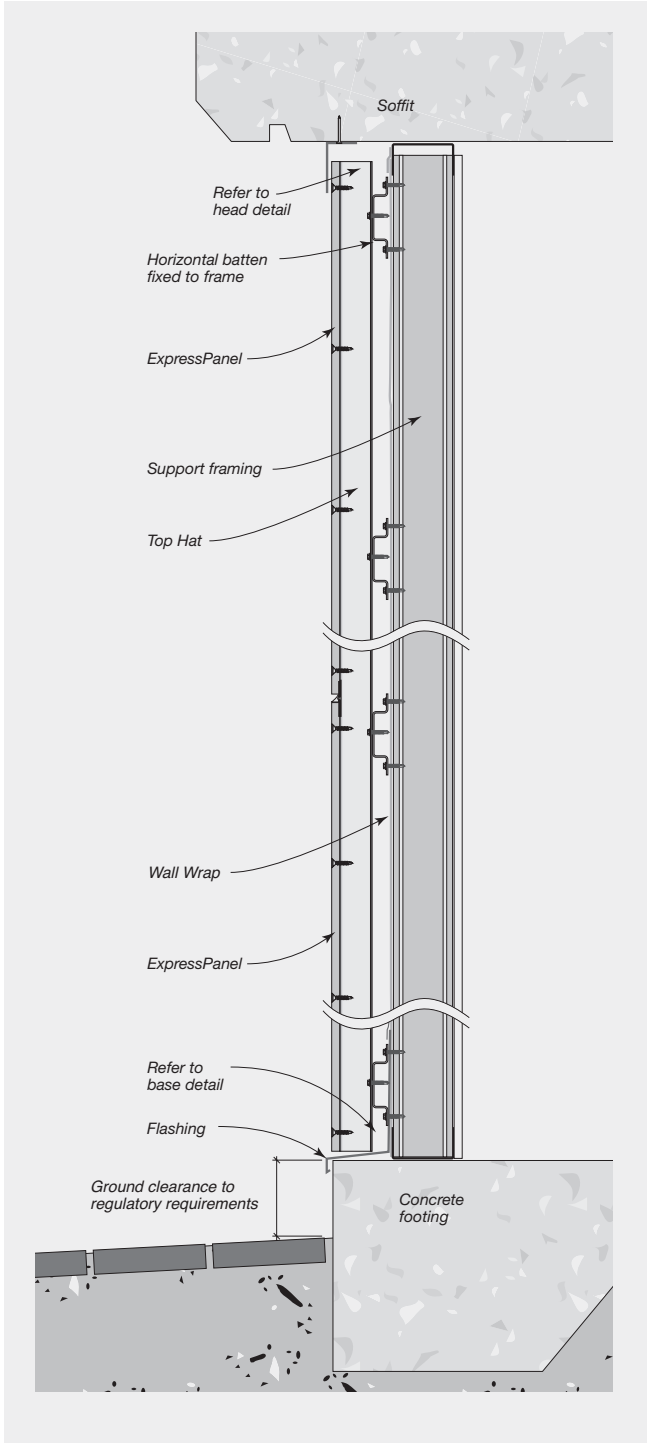


FIGURE 8.06 Eaves/Deflection Head – Ventilated

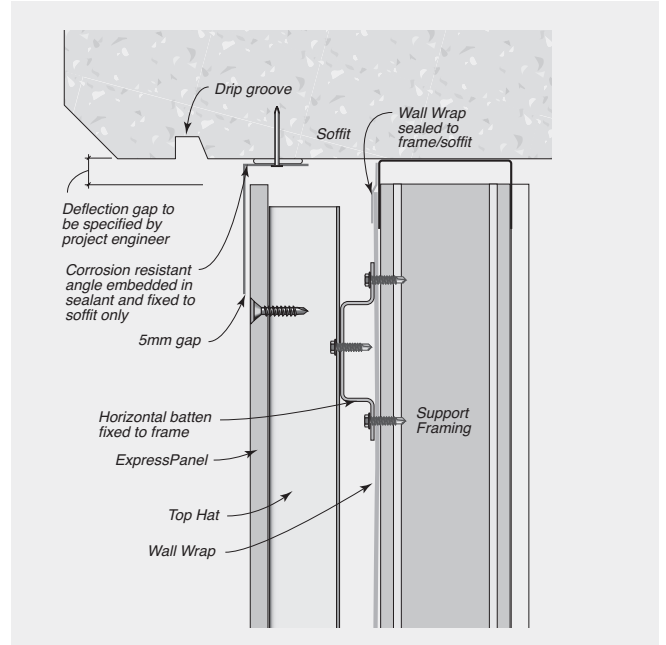
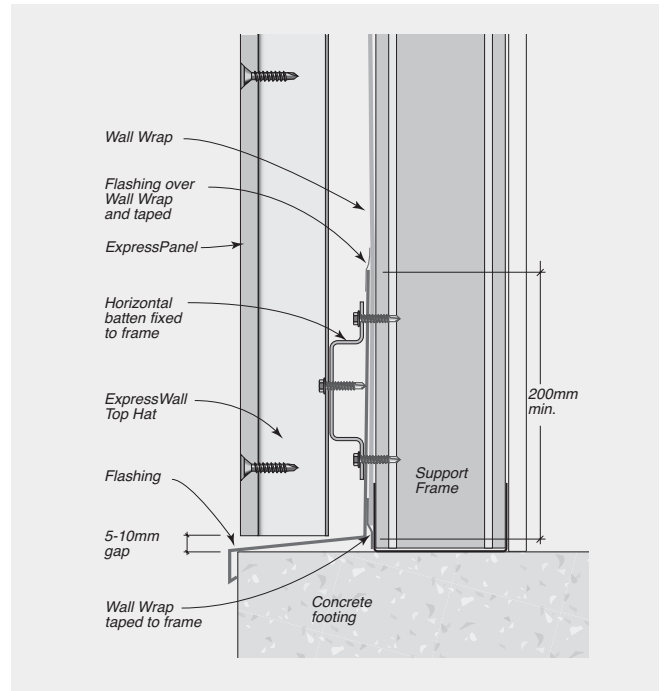


FIGURE 8.07 Base Detail – Drained





CONSTRUCTION DRAWINGS AND DETAILS

Note: Drawings are interchangeable for timber or steel substrates with the exception of the fasteners.

Ventilated Cavity System

FIGURE 8.08 External Corner

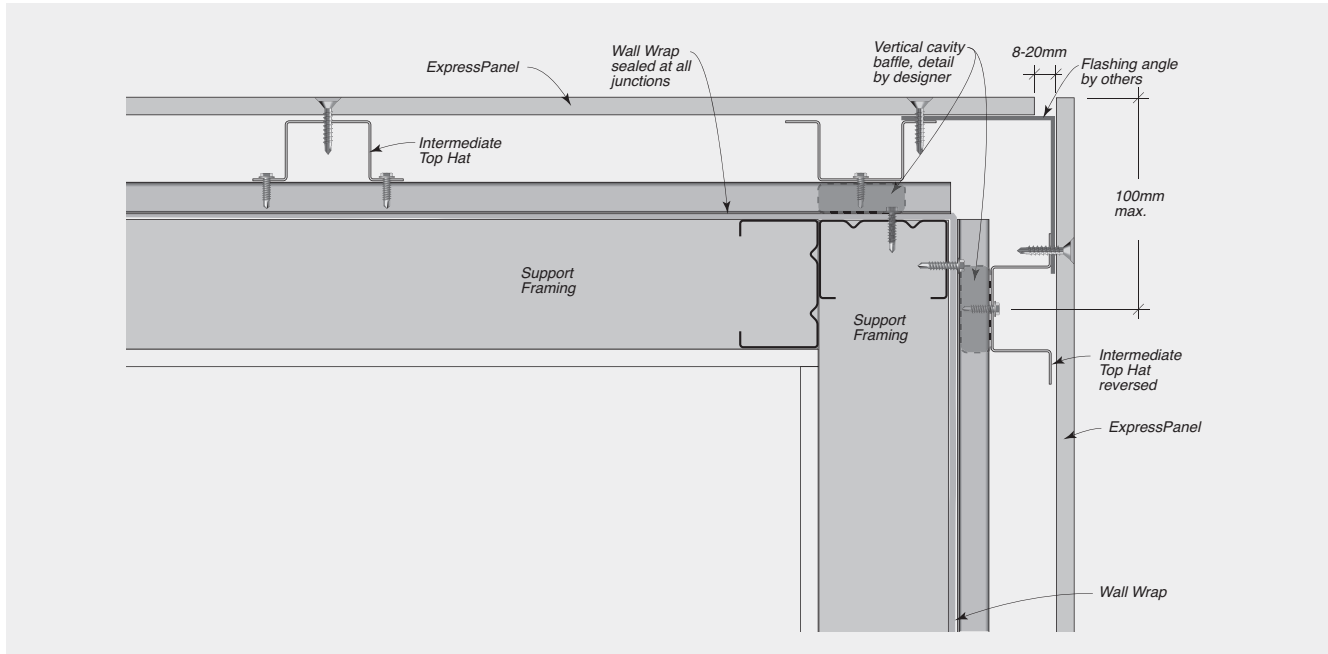


FIGURE 8.09 External Corner - Obtuse Angle

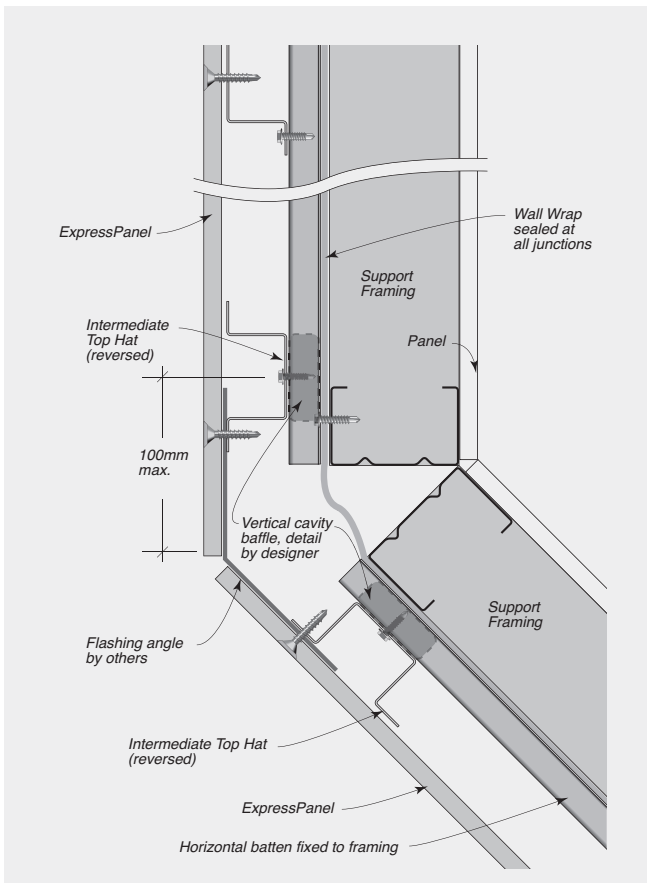
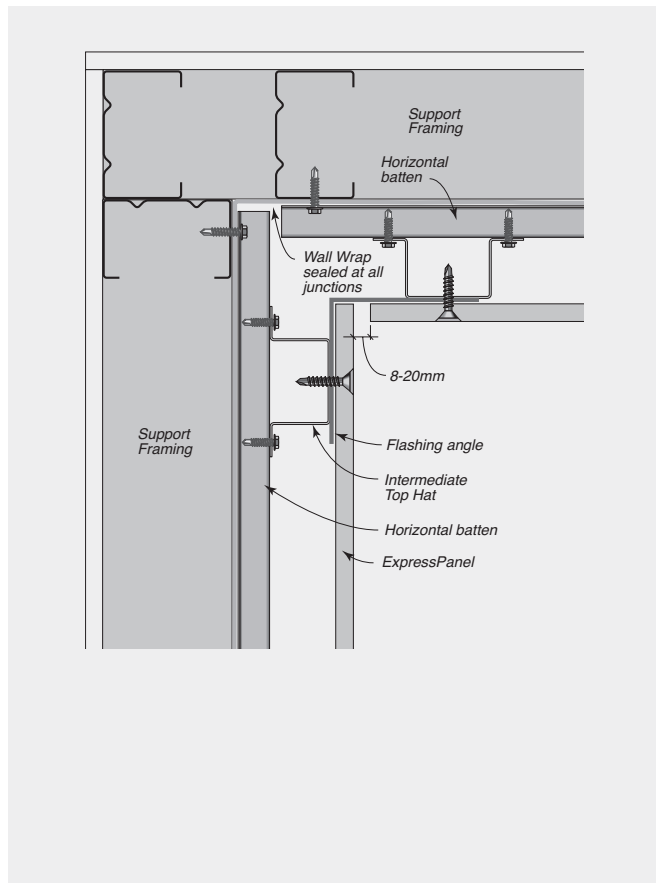


FIGURE 8.10 Internal Corner Detail



CONSTRUCTION DRAWINGS AND DETAILS



Note: Drawings are interchangeable for timber or steel substrates with the exception of the fasteners.

Ventilated Cavity System

FIGURE 8.11 Framed Soffit

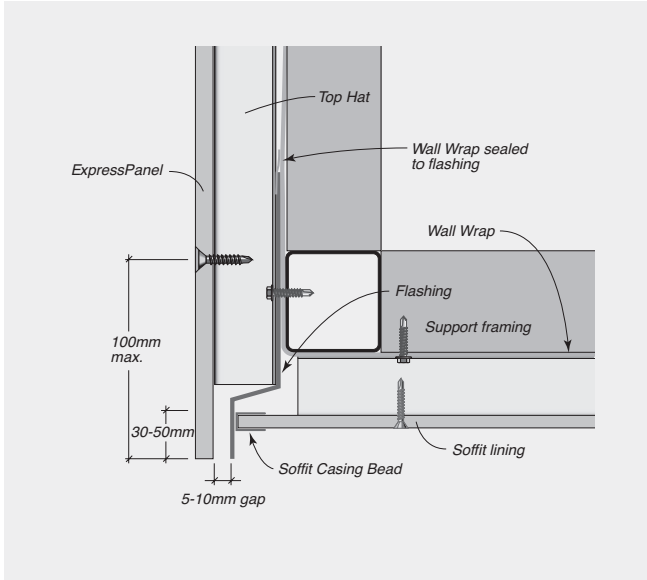


FIGURE 8.12 Control Joint - Vertical

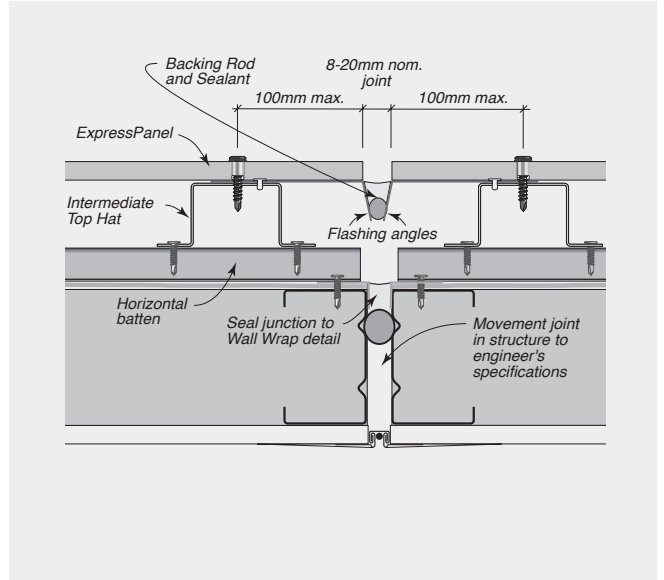


FIGURE 8.13 Inter-Storey Junction with Flashing

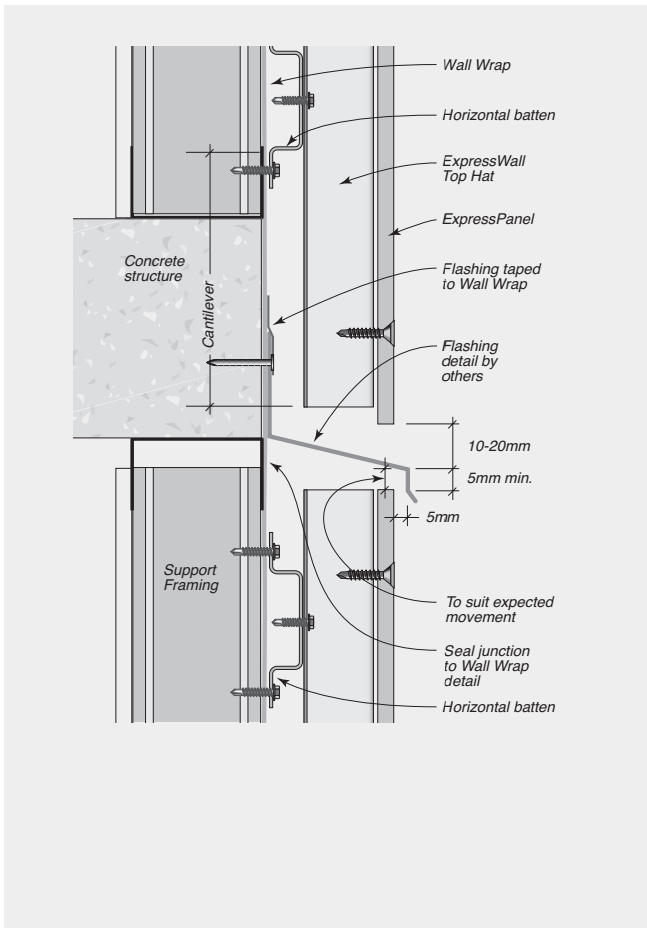
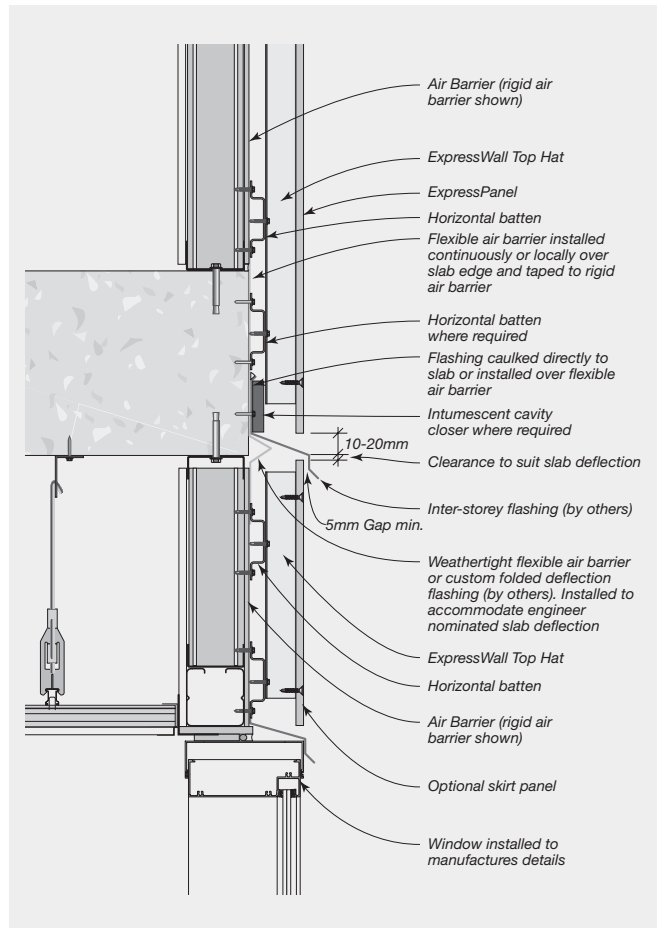


FIGURE 8.14 Inter-Storey Junction with Flashing



CONSTRUCTION DRAWINGS AND DETAILS



Note: Drawings are interchangeable for timber or steel substrates with the exception of the fasteners.

Ventilated Cavity System

FIGURE 8.18 Parapet Capping

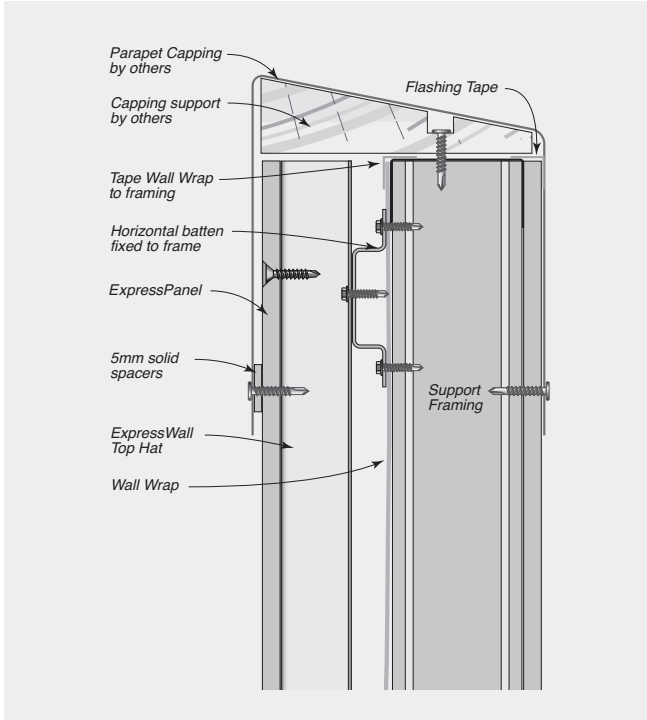


FIGURE 8.19 Balcony Base

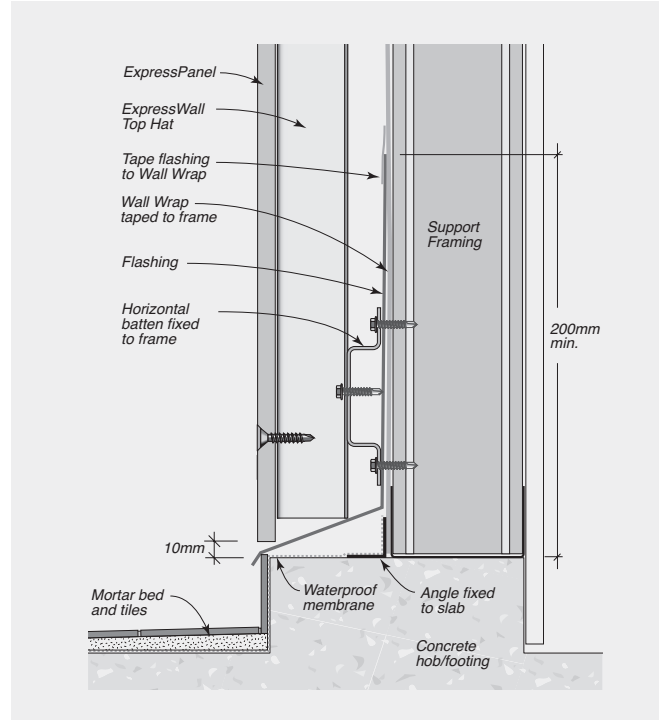
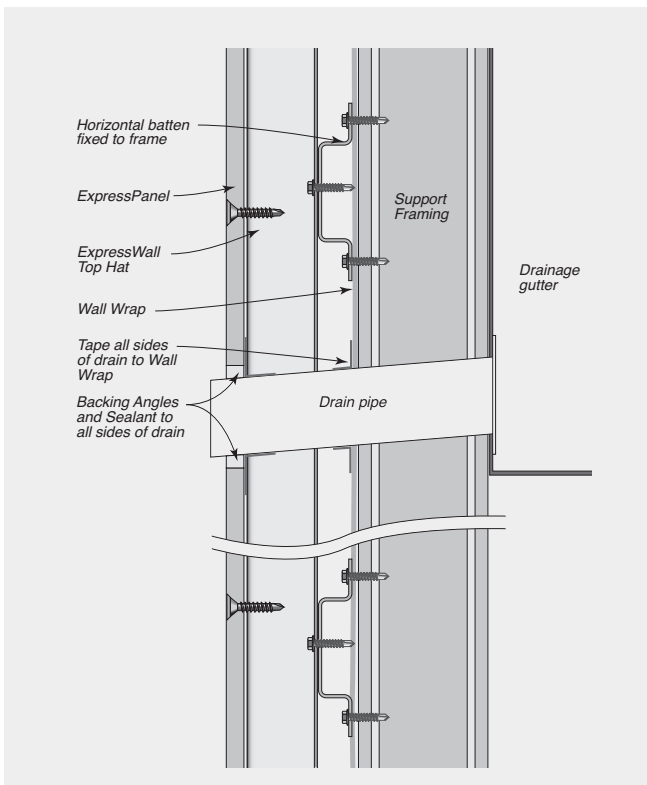


FIGURE 8.20 Typical Drain





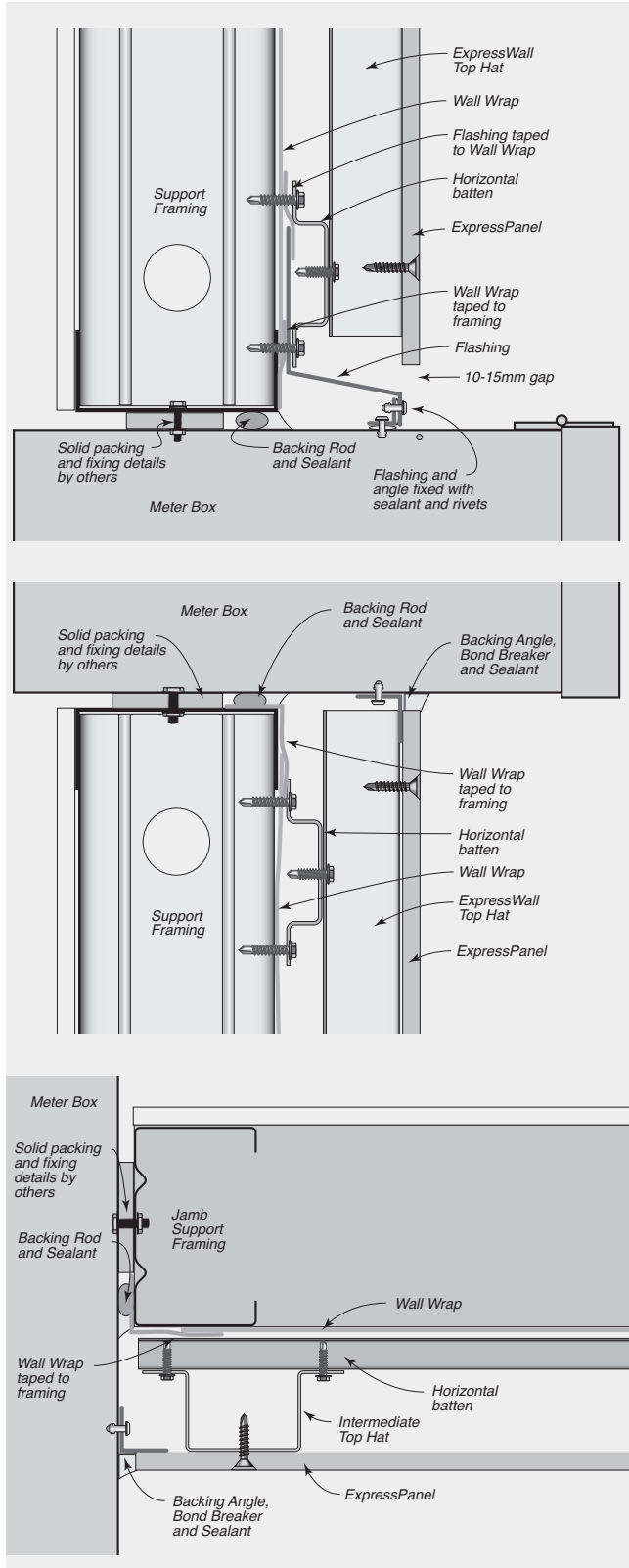
CONSTRUCTION DRAWINGS AND DETAILS

Note: Drawings are interchangeable for timber or steel substrates with the exception of the fasteners.

Ventilated Cavity System

FIGURE 8.21 Typical Power/Meter Box

Note: Refer to local authority for specific meter box installation requirements.



CONSTRUCTION DRAWINGS AND DETAILS



Note: Drawings are interchangeable for timber or steel substrates with the exception of the fasteners.

Ventilated Cavity System – Sealant Filled Joint Detail

FIGURE 8.22 Sealant Filled Joint Construction – Ventilated Cavity System

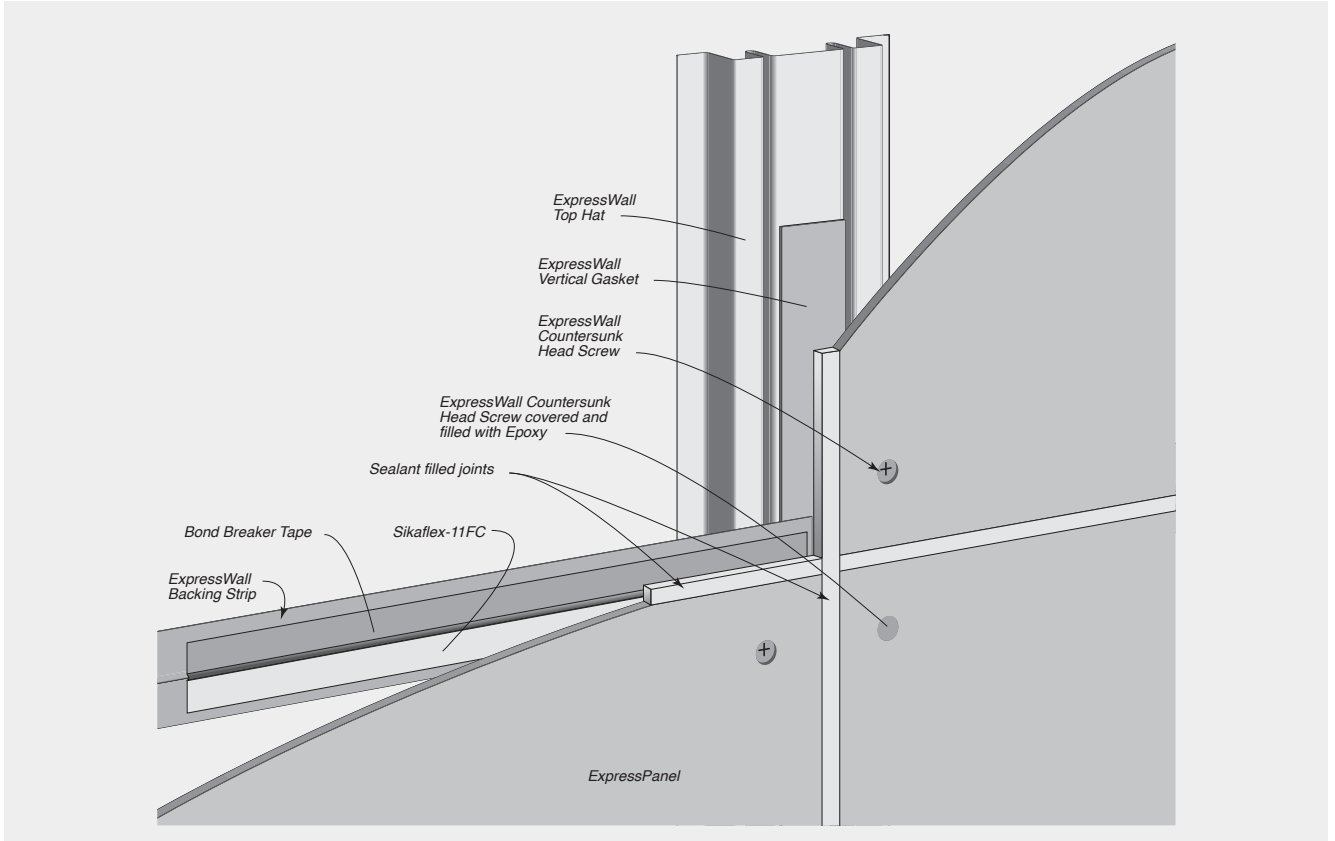


FIGURE 8.23 Backing Strip Preparation

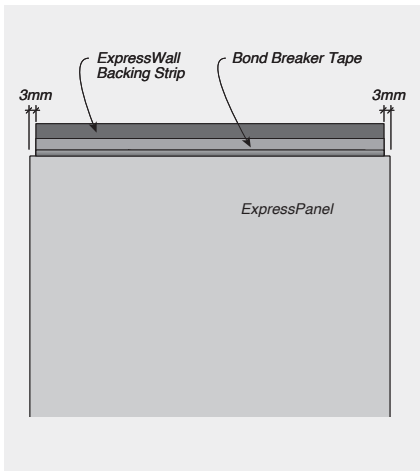


FIGURE 8.24 Horizontal Joint – Sealant filled

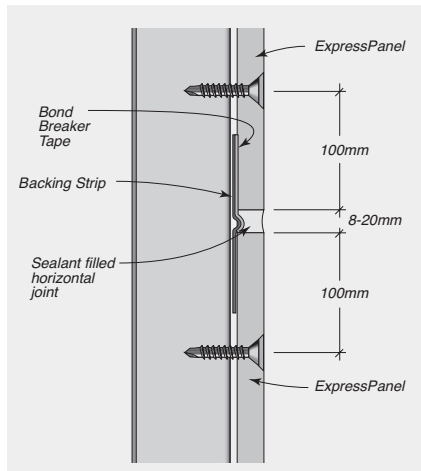
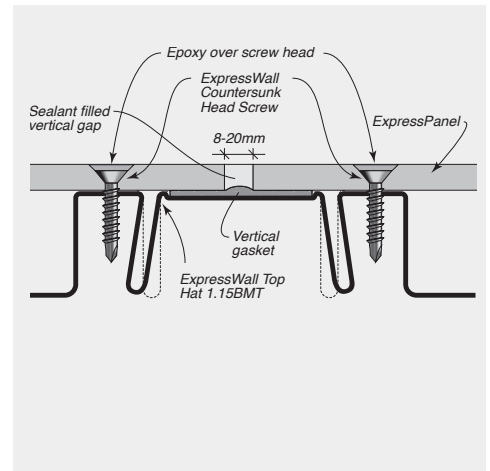


FIGURE 8.25 Vertical Joint – Sealant filled





CONSTRUCTION DRAWINGS AND DETAILS

Note: Drawings are interchangeable for timber or steel substrates with the exception of the fasteners.

Ventilated Cavity System – Sealant Filled Joint Detail

FIGURE 8.26 Typical ExpressWall System Cross Section for Steel Framing – Joints sealant filled

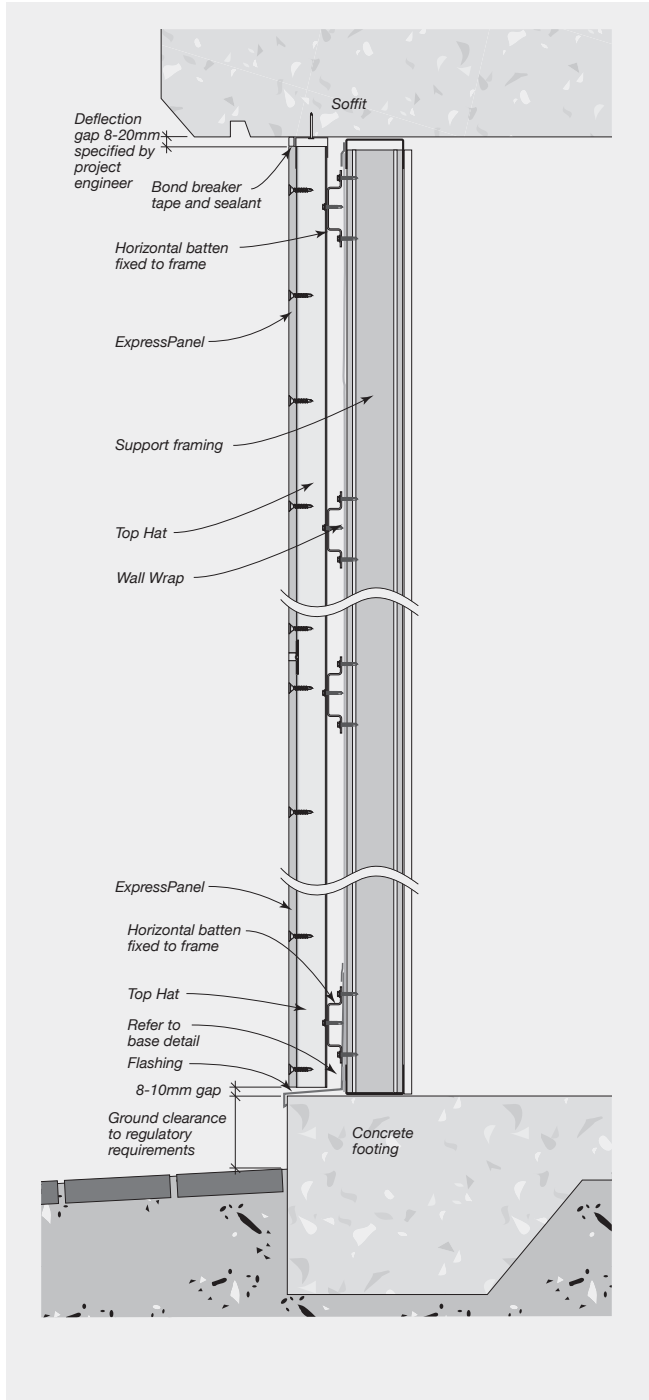


FIGURE 8.27 Eaves/Deflection Head – Sealant filled

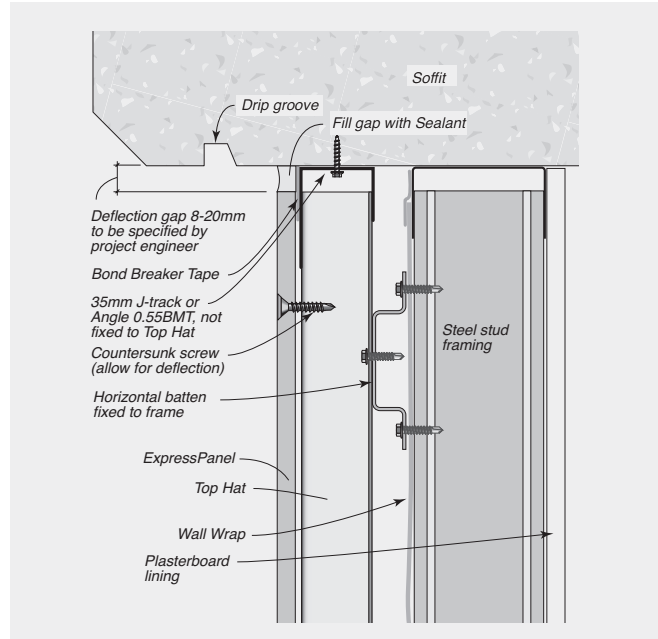
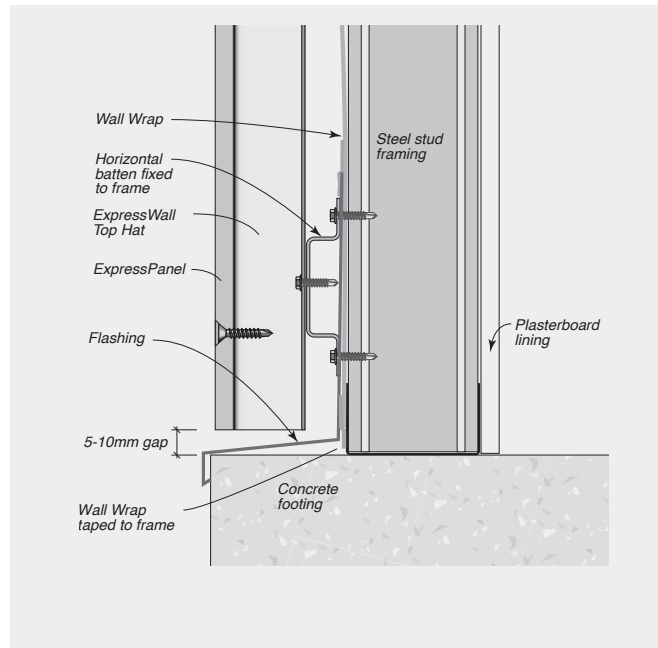


FIGURE 8.28 Base Detail – Drained



CONSTRUCTION DRAWINGS AND DETAILS



Note: Drawings are interchangeable for timber or steel substrates with the exception of the fasteners.

Ventilated Cavity System – Sealant Filled Joint Detail

FIGURE 8.29 Internal Corner Detail – Sealant filled

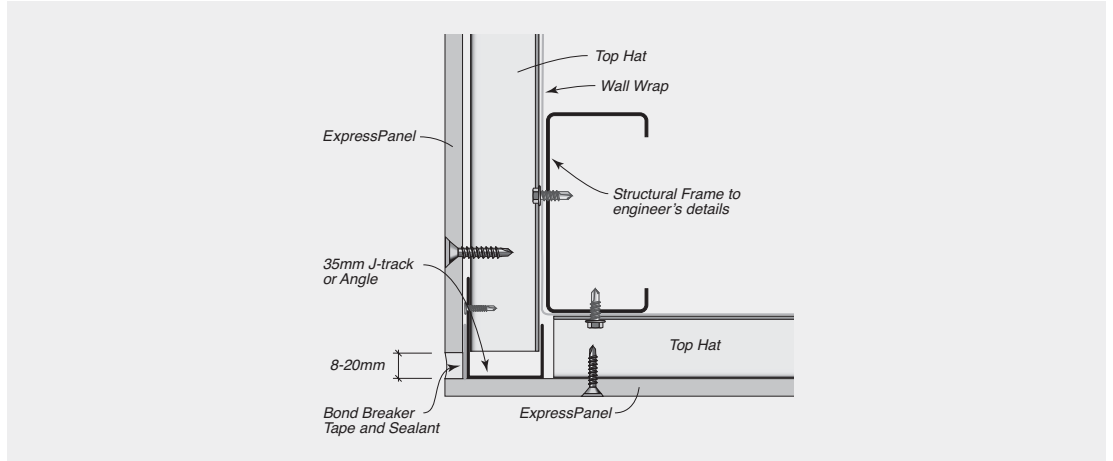
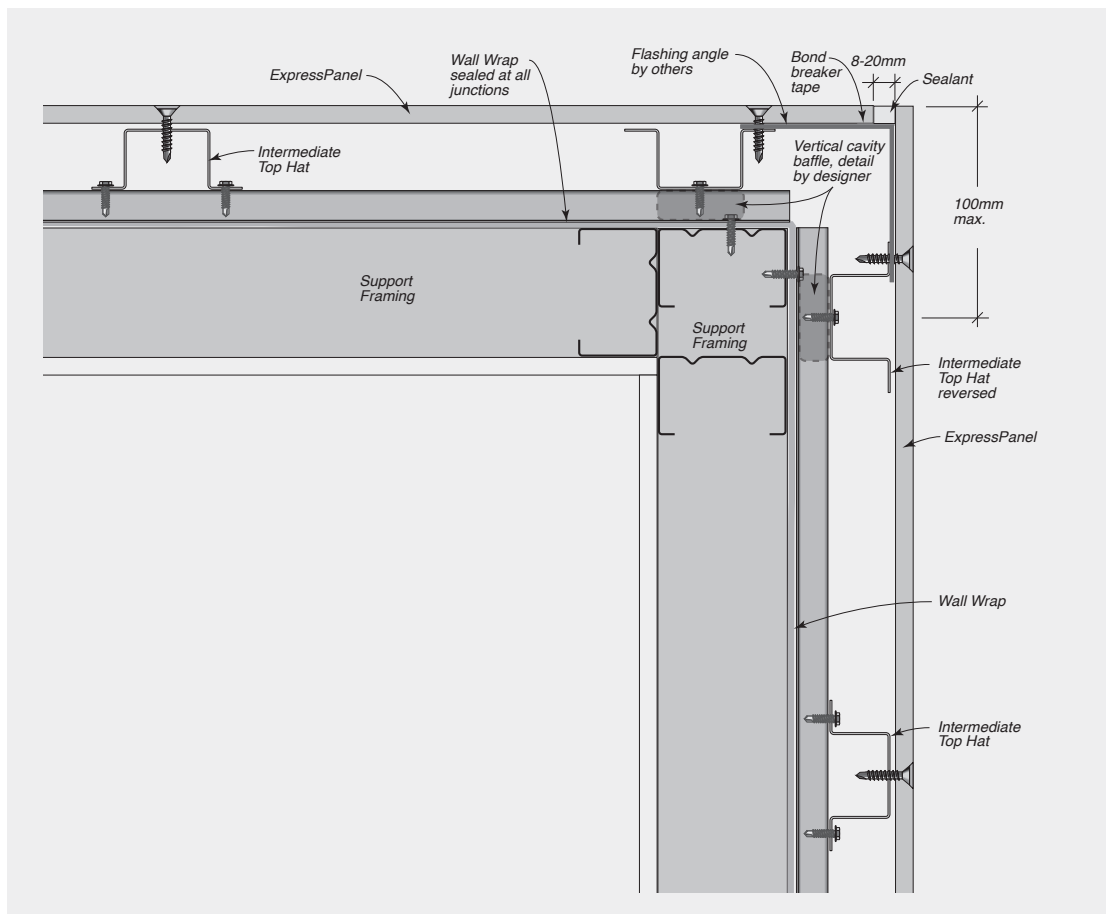


FIGURE 8.30 External Corner – Sealant filled



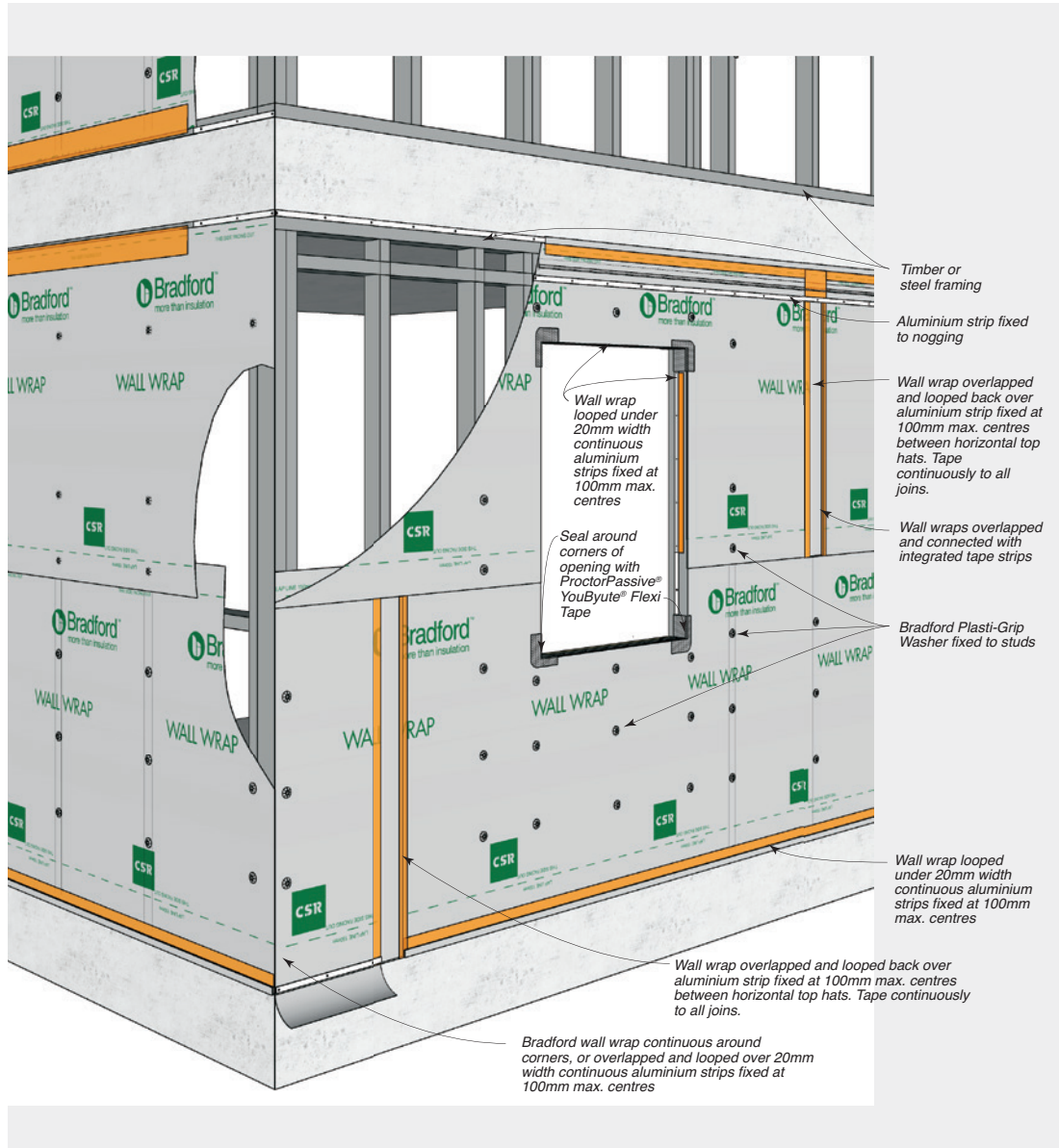


CONSTRUCTION DRAWINGS AND DETAILS

Note: Drawings are interchangeable for timber or steel substrates with the exception of the fasteners.

Soft Air Barrier

FIGURE 8.31 Typical Installation Overview – Soft Air Barrier



CONSTRUCTION DRAWINGS AND DETAILS



Note: Drawings are interchangeable for timber or steel substrates with the exception of the fasteners.

Soft Air Barrier

FIGURE 8.32 External Corner – Wall Wrap Continuous

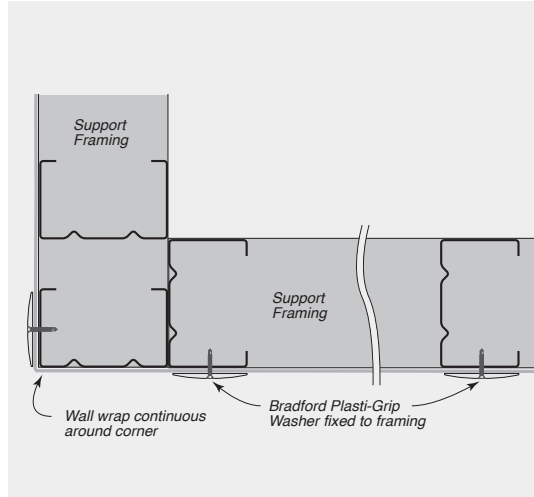


FIGURE 8.33 External Corner – Wall Wrap Overlapped

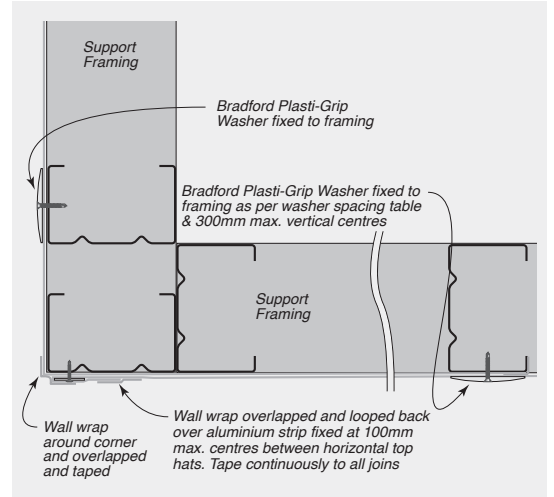


FIGURE 8.34 Internal Corner – Wall Wrap Continuous

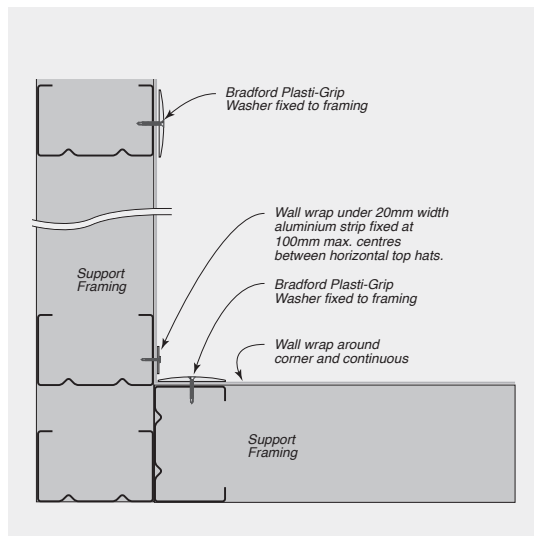


FIGURE 8.35 Internal Corner – Wall Wrap Overlapped

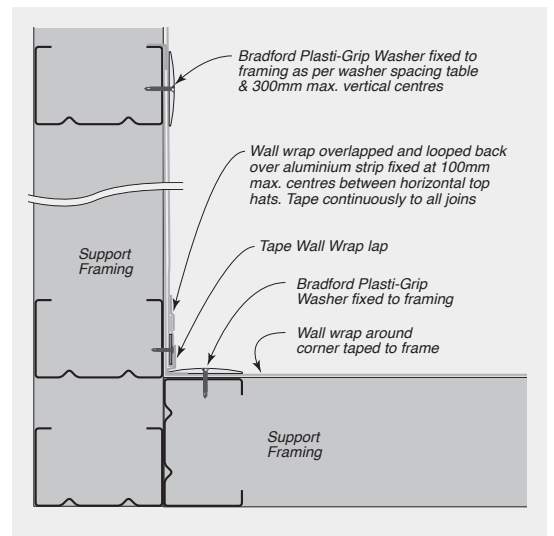
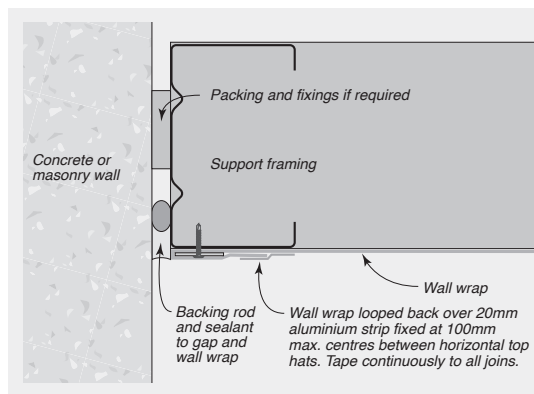


FIGURE 8.36 Abutment to Concrete or Masonry Wall





CONSTRUCTION DRAWINGS AND DETAILS

Note: Drawings are interchangeable for timber or steel substrates with the exception of the fasteners.

Soft Air Barrier

FIGURE 8.37 Wall Wrap Installation to Wall, Soffit and Base

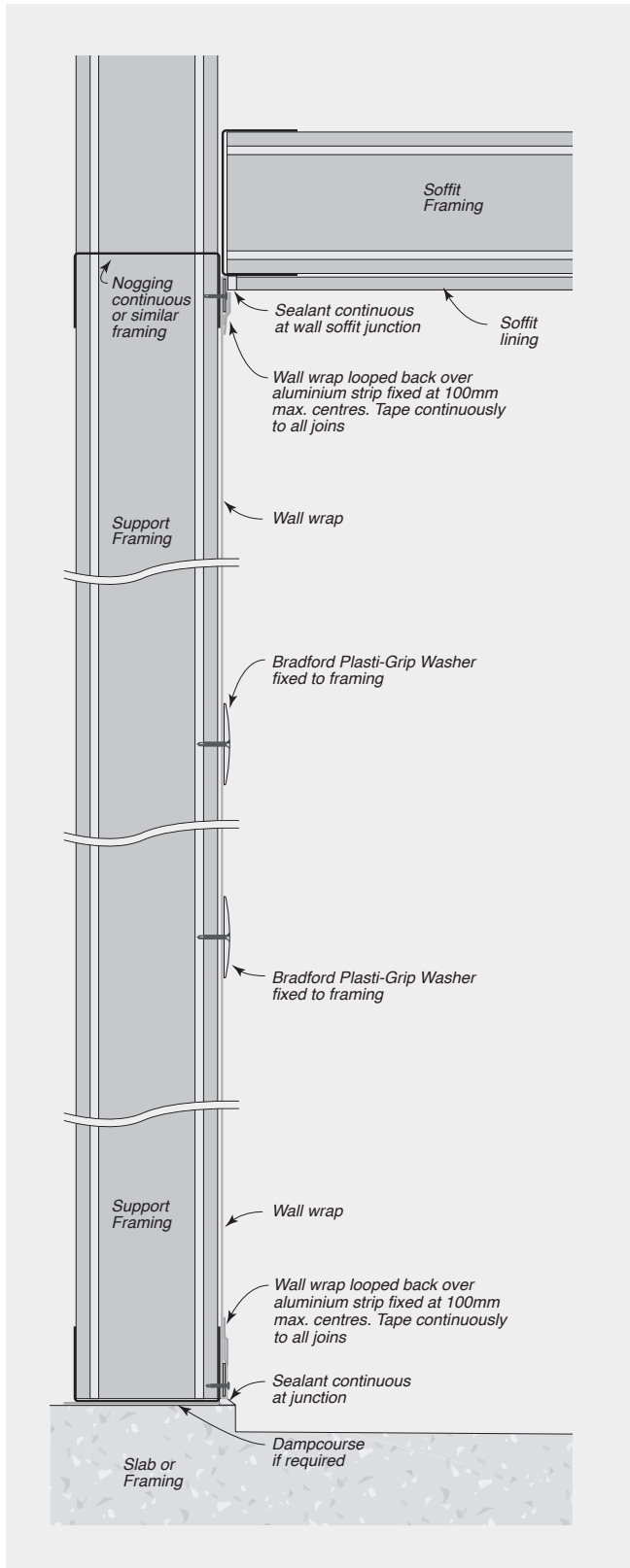
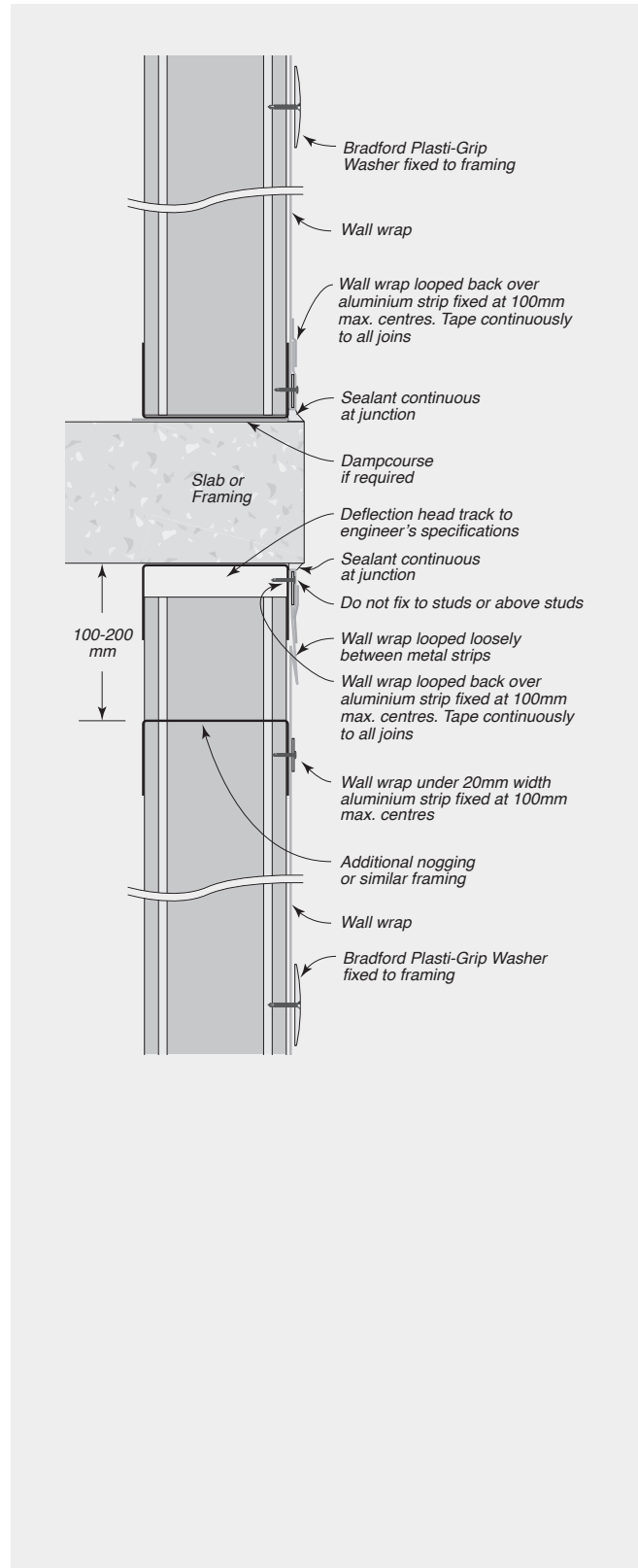


FIGURE 8.38 Wall Wrap Installation at Intermediate Level Junction - Non-loadbearing Steel Framing With Deflection Head



CONSTRUCTION DRAWINGS AND DETAILS



Note: Drawings are interchangeable for timber or steel substrates with the exception of the fasteners.

Soft Air Barrier

FIGURE 8.39 Vertical Wall Wrap Junction – Overlapped Double Strip Join

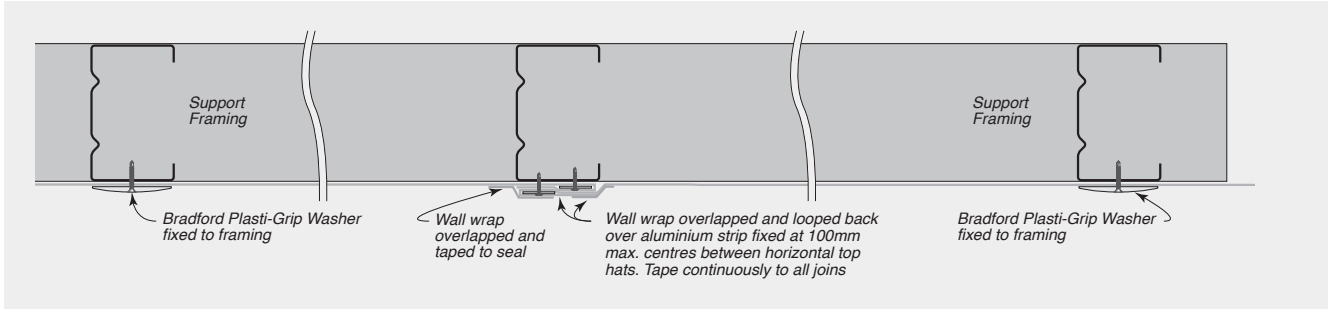


FIGURE 8.40 Vertical Wall Wrap Junction – Overlapped Single Strip Join

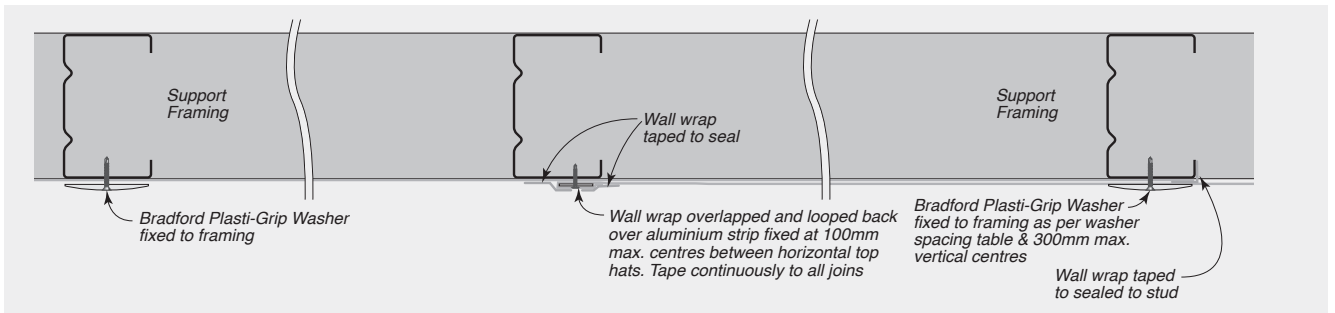


FIGURE 8.41 Vertical Wall Wrap Junction – At Control joint

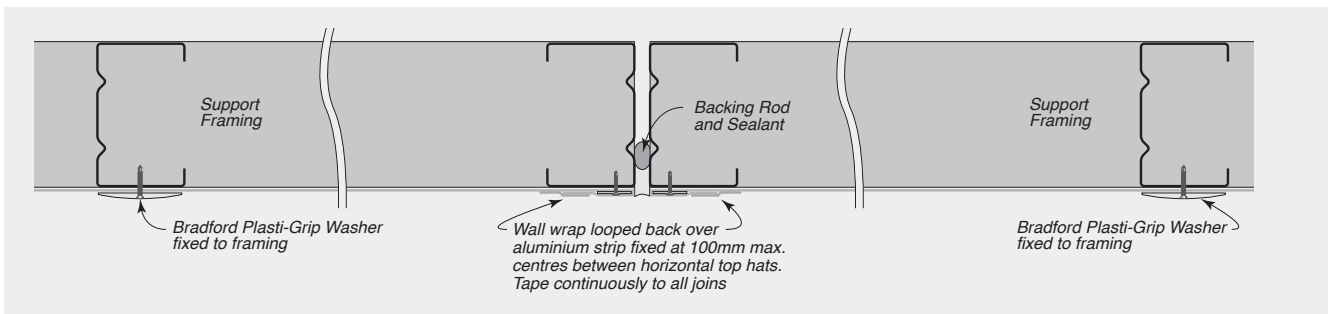
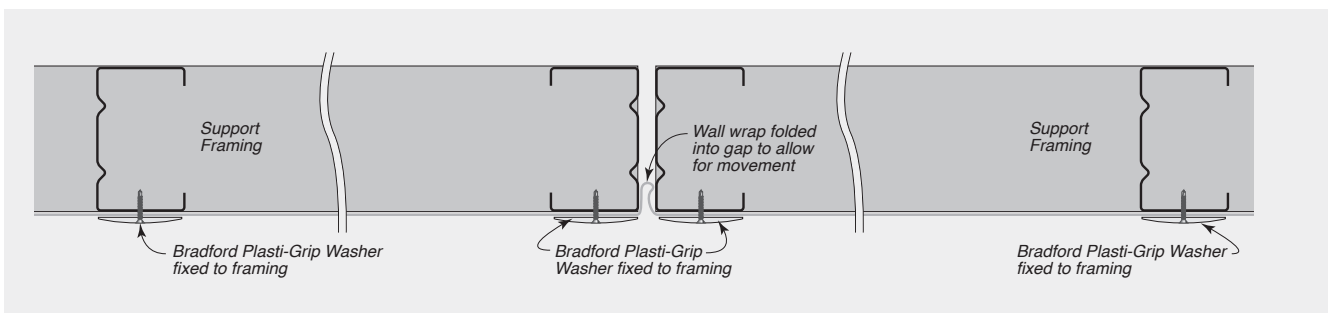


FIGURE 8.42 Vertical Wall Wrap Junction – No Lap Double Washer





CONSTRUCTION DRAWINGS AND DETAILS

Note: Drawings are interchangeable for timber or steel substrates with the exception of the fasteners.

Soft Air Barrier

FIGURE 8.43 Wall Wrap Installation at Window/Door Opening

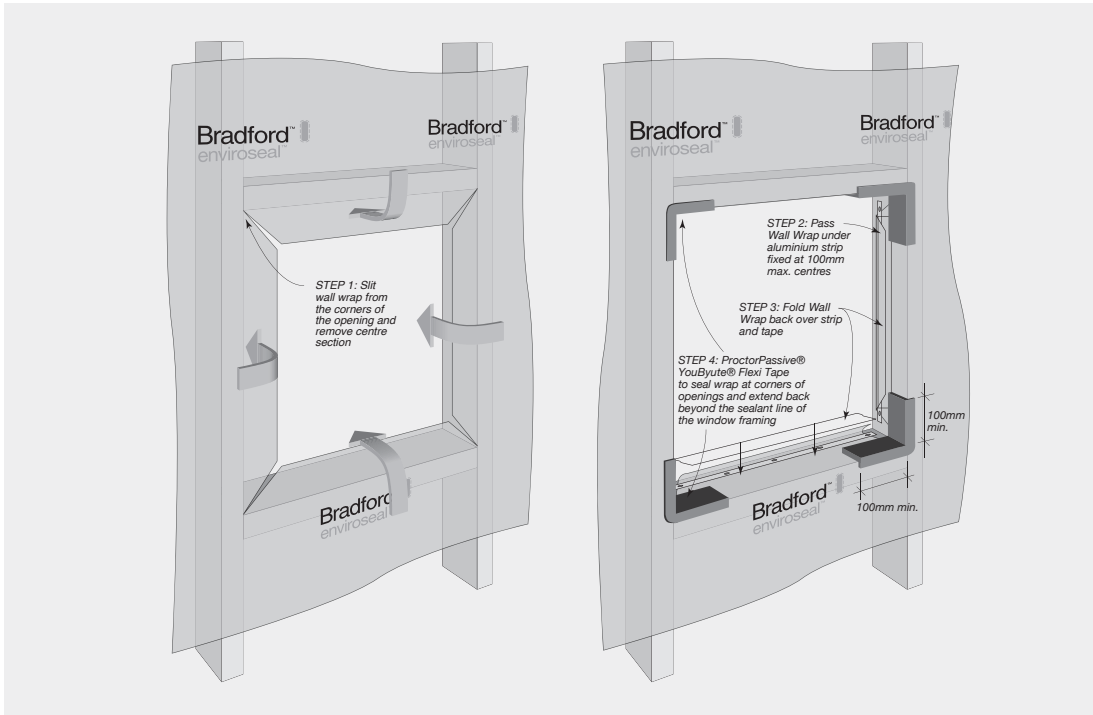
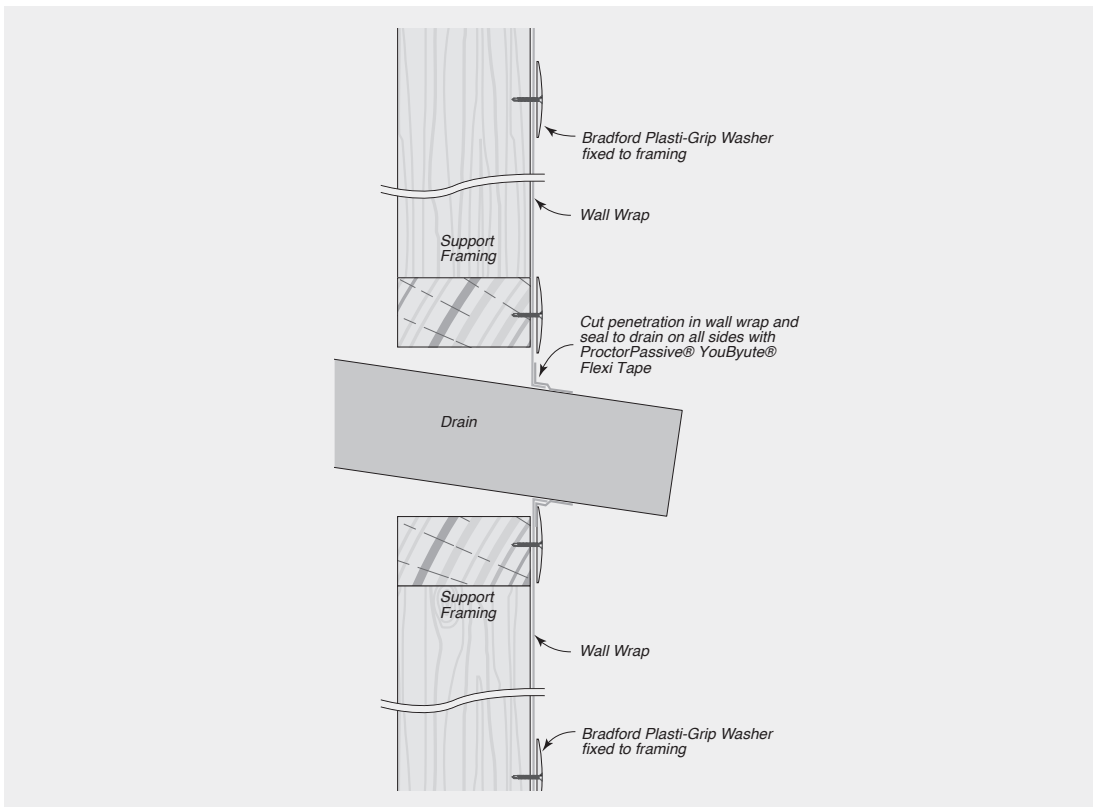


FIGURE 8.44 Wall Wrap Installation at Drain Penetration - Timber or Steel Framing



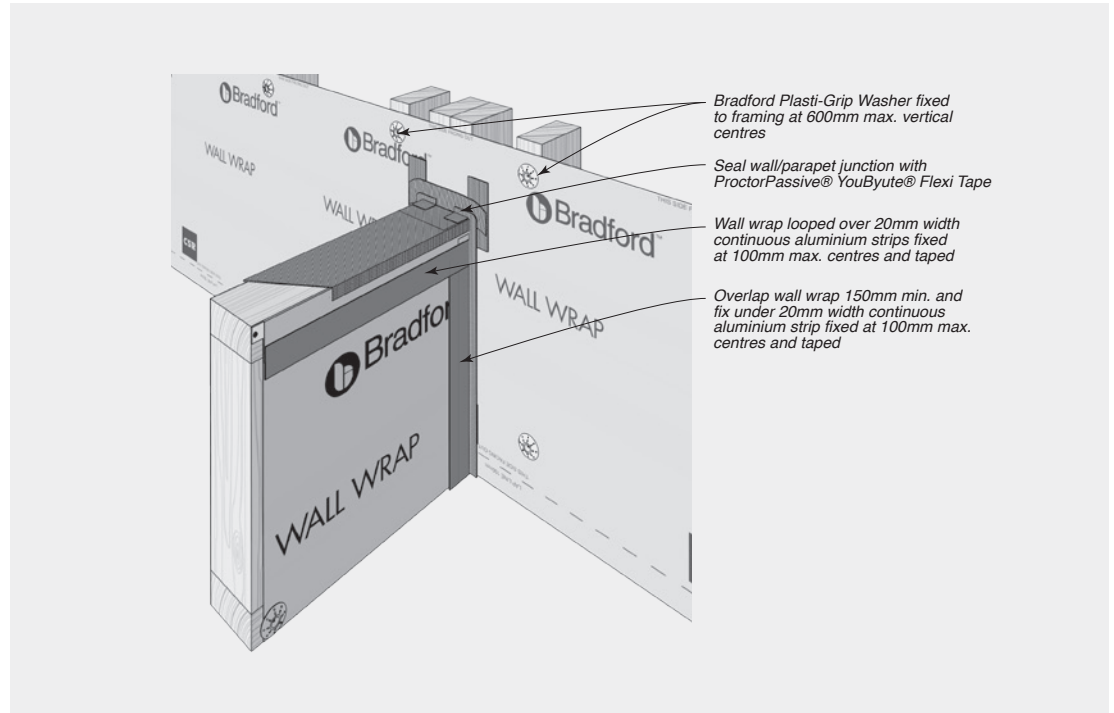
CONSTRUCTION DRAWINGS AND DETAILS



Note: Drawings are interchangeable for timber or steel substrates with the exception of the fasteners.

Soft Air Barrier

FIGURE 8.45 Wall Wrap Installation at Parapet Junction – Timber or Steel Framing





SAFETY, HANDLING, GENERAL CARE
+ WARRANTY

SAFETY, HANDLING, GENERAL CARE + WARRANTY



Health, Safety and Personal Protection Equipment (PPE)

Fibre Cement contain silicas that are harmful if inhaled. Protective clothing and breathing equipment should be worn when cutting products.

When cutting, drilling or grinding fibre cement panels using power tools, always ensure the work area is properly ventilated.

An approved dust mask (AS/NZS 1715 and AS/NZS 1716) and safety glasses (AS/NZS 1337) must be worn. Cemintel recommends that hearing protection also be worn.

Safety Data Sheet information is available at www.cemintel.com.au



Managing Respirable Crystalline Silica Dust

Crystalline Silica is everywhere. It is found naturally in stone, rocks, sand, gravel and clay. Sand is one of the raw materials in Fibre Cement. Respirable Crystalline Silica dust is the fine dust that's created when you use power tools to cut, drill, grind, chip or sand materials and products that contain crystalline

silica. This dust is of concern due to its size as it gets caught deep in your lungs and can cause long term damage.

IF YOU USE THE CORRECT SAFETY EQUIPMENT AND PPE, FIBRE CEMENT IS SAFE TO USE.



Cemintel Safety Requirements

1 - Cut Outdoors*	The ventilation outdoors is greater than that indoors, and therefore should reduce exposure.
2 - Use On-Tool Dust Extraction	Use on-tool dust extraction when using power tools to drill and cut Fibre Cement, with a vacuum that contains a HEPA M Class filter.
3 - Correct Saw and Blade	Use a plunge saw with a specifically designed Fibre Cement blade.
4 - Don't Sweep, Vacuum instead	When completing your work vacuum with a HEPA M Class filter, rather than a broom as sweeping creates more dust.
5 - Use Correct Respirator	Use a half face P1 or P2 respirator. It is essential that the respirators are Fit Tested and workers are cleanly shaven to obtain a good seal.

* Even though not recommended, indoor cutting can be completed when using an onsite cutting room with exhaust ventilation and a M class filter at a minimum, on-tool dust extraction with a vacuum with a HEPA M Class filter, a Full Face P2 respirator and conducting local occupational and static air monitoring to validate effectiveness of control measures.

Safety, Handling, and Maintenance

Storage

All Cemintel panels must be stacked flat, clear of the ground and supported at 300mm maximum centres on a level platform. Panels must be kept dry, preferably stored inside the building. Panels must be dry prior to fixing, hence if it is necessary to store outside, the product must be protected from the weather.

Handling

Prefinished products and must be treated with care during handling to avoid damage to edges, ends and prefinished surface. Panels should be carried horizontally on edge by at least two people.

Consideration should be given to planning the order of other trades that might stain or damage the panels.

Any splashing of mud, cement, mortar and the like should be removed immediately.

Warranty

Cemintel Commercial ExpressPanel sheets have a product warranty of 10 years.

The full product warranty is available for download at cemintel.com.au

Cutting

Panels should be fully supported and cut from the back using a power saw. Cemintel recommends using the Makita Plunge Cut Saw with guide rail and appropriate blade, together with the appropriate dust extraction system. All exposed cut edges **MUST BE SEALED WITH CEMINTEL EDGE SEALER TO PREVENT MOISTURE ABSORPTION.**

Mitres

It is not recommended to mitre panel edges as this can cause delamination of the face.

Penetrations

Penetrations in panels may be cut or drilled prior to installation. Cut from the back or drill from the front. Mask, prime and fill gaps with sealant in accordance with recommended methods and products.







Our Offices

Sydney

376 Victoria Street
Wetherill Park NSW 2164

Adelaide

Lot 100 Sharp Court
Mawson Lakes SA 5095

Darwin

Cnr Stuart Highway
& Angliss Street
Berrimah NT 0828

Melbourne

277 Whitehall Street
Yarraville VIC 3013

Perth

19 Sheffield Road
Welshpool WA 6106

Brisbane

768 Boundary Road
Coopers Plains QLD 4108

Hobart

11 Farley Street
Derwent Park TAS 7009

cemintel.com.au
1300 236 468

For Design and Technical Support:
DesignLINK – 1800 621 117

Cemintel is a trading entity of CSR Building Products Limited (ACN 008 631 356).

The products referred to in this document have been manufactured by or on behalf of CSR Building Products Limited ("CSR") to comply with the Building Code of Australia and any relevant Australian Standards. While any design or usage guidelines set out in this document have been prepared in good faith by CSR, they are of a general nature only and are intended to be used in conjunction with project specific design and engineering advice.

It is the responsibility of the customer to ensure that CSR's products are suitable for their chosen application, including in respect of project-specific matters such as, but not limited to structural adequacy, acoustic, fire resistance/combustibility, thermal, and weatherproofing requirements. All information relating to design/installation/application of these products is offered without warranty and no responsibility can be accepted by CSR for errors and omissions, or for any use of the relevant products not in accordance with CSR's technical literature or any other relevant industry standards. For current technical and warranty documentation relating to Cemintel's products, visit Cemintel's website at www.cemintel.com.au.