

CEMINTEL®

DESIGN AND INSTALLATION GUIDE



ceminseal®
WATER BLOCK
TECHNOLOGY



CEILING SYSTEMS – SOFFITLINE® & CEMINSEAL® WALLBOARD
External & Internal Ceiling Systems

CSR

CONTENTS

DESCRIPTION	2
APPLICATIONS	2
ADVANTAGES	2
PANEL INFORMATION	3
DESIGN CONSIDERATIONS	4
CEILING SYSTEM SELECTION	7
COMPONENTS & ACCESSORIES	8
INSTALLATION PROCEDURE	10
INSTALLATION METHODS	13
INSTALLATION DETAILS FOR SOFFITLINE® CEILING SYSTEMS – EXTERNAL CEILING WITH FLUSH-SET JOINTS	14
INSTALLATION DETAILS FOR EXTERNAL CEILING SYSTEMS – WITH EXPRESSED JOINTS	18
INSTALLATION DETAILS FOR INTERNAL CEILING SYSTEMS – WITH FLUSH-SET JOINTS	22
JOINTING	26
HEALTH & SAFETY	27
WARRANTY	27

DESCRIPTION

Cemintel® Ceiling Systems are designed for external and internal applications, and are suitable for use with steel and timber framing. Systems are available with expressed joints or with flush-set joints. They are easy to install and require minimal maintenance.

The Cemintel SoffitLine® system is recommended for external use where a flush joint appearance is required. The system comprises of SoffitLine sheets fixed to furring channels on a variety of framing types. SoffitLine is a fibre cement panel that is formulated with a unique penetrating waterblock technology for added weather resistance and durability. It is used with a purpose designed acrylic jointing system that has increased joint strength and reduces the need for sanding.

For internal ceilings, CeminSeal® Wallboard is used. It also includes waterblock technology and has a smooth flat surface for easy finishing. It is available in recessed edge (RE) for a flush jointed finish, or square edge (SE) for an expressed joint finish.

APPLICATIONS

Cemintel SoffitLine has been developed for use in flush jointed external ceilings such as those found in:

- Retail and Industrial Awnings;
- Verandahs, Balconies (Residential and High-Rise) and Car Parks; and
- Car Park Canopies.

CeminSeal Wallboard (SE) lining is suitable for internal use for expressed joint ceilings and may also be used in high humidity internal areas such as indoor pools. For more information, refer to 'INDOOR POOL DESIGN CONSIDERATIONS' on page 6.

CeminSeal Wallboard (RE) lining is suitable for use in flush jointed internal ceilings in applications such as:

- Sports Halls;
- Secure Areas; and
- Industrial Storage Areas.

Recessed Edge CeminSeal Wallboard is suitable for most internal applications. It remains the responsibility of the building designer to verify a particular system is suitable for the requirements of a project.

ADVANTAGES

- Expressed joint or flush joint appearance.
- High strength jointing system with reduced sanding.
- Easy installation.
- Internal and external applications.
- Smooth surface ready for finishing.
- Accepts a wide range of paint finishes.



PANEL INFORMATION

LININGS

SoffitLine is an autoclaved, cellulose reinforced fibre cement panel which is formulated with a unique penetrating water block technology for added weather resistance and durability. Panels are tinted lilac and long edges are recessed.

SoffitLine is 6mm in thickness.

SoffitLine Panel Sizes (6mm thickness)		
Length	Width (mm)	Product Code
3600	1200	94712

CeminSeal Wallboard is an autoclaved, cellulose reinforced fibre cement panel for use in ceilings and interior wet areas. It is available with long edges recessed (RE) or a square edge finish (SE). CeminSeal Wallboard is available in 6mm and 9mm thickness.

CeminSeal Wallboard Panel Sizes and Product Codes (6mm thickness)				
Length	CeminSeal Wallboard RE			CeminSeal Wallboard SE
	Width (mm)			Width (mm)
	900	1200	1350	1200
1800	–	95827	–	–
2400	–	95828	95843	95850
2700	–	95829	–	95851
3000	95826	95830	95844	95852
3600	–	95841	95845	95861
4200	–	95842	95846	–

CeminSeal Wallboard Panel Sizes and Product Codes (9mm thickness)		
Length	CeminSeal Wallboard RE	CeminSeal Wallboard SE
	Width (mm)	
	1200	
2400	95847	–
2700	95848	95862
3000	95849	95863

PRODUCT SPECIFICATIONS

Cemintel fibre cement products conform to the requirements of AS/NZS 2908.2, 'Cellulose cement products Part 2: flat sheets' for Type B Category 3.

Wallboard – Mass (6mm thickness nominal)	9.7kg/m ²
Wallboard – Mass (9mm thickness nominal)	14.3kg/m ²
SoffitLine – Mass (6mm thickness nominal)	9.7kg/m ²
Length (manufacturing tolerance)	+0 to -4mm
Width (manufacturing tolerance)	+0 to -3mm
Thickness (manufacturing tolerance)	+0.5 to -0mm

FIRE HAZARD PROPERTIES

The Building Code of Australia limits the materials used in Class 2 to 9 buildings by controlling the Fire Hazard properties of linings. These properties are assessed using AS/ISO9705 room burn test, AS/NZS 3837 the cone calorimeter test, AS1530.2 and AS1530.3.

The fire hazard properties for SoffitLine and CeminSeal Wallboard are as follows:

Ignitability	0
Spread of Flame	0
Heat Evolved	0
Smoke Developed	0
ASE	<250m ² /kg
Group Number	1

Note: SMOGR_{Arc} = Smoke Growth Rate Index
ASE: Average Specific Extinction Area

In accordance with the BCA, C1.9, Cemintel fibre cement sheet products may be used wherever a non-combustible material is required.

DESIGN CONSIDERATIONS

SYSTEM SELECTION/WIND LOADING

External ceilings are subject to wind loads and the design of framing and fixings must be based on the project's site conditions. Factors that must be assessed to determine wind loading include the wind speed region, the terrain category in the vicinity of the site, and shielding from nearby buildings. Local pressure factors for the ceiling lining may also apply to some ceiling areas.

It is the responsibility of the building designer to determine the applicable pressures or 'Wind Class' for the ceiling. System span tables are provided to suit residential buildings within the scope of AS4055 'Wind loads for housing' and for design to AS1170.2, the wind loading code, for other buildings and structures.

CEILING FRAMING

The Cemintel Ceiling Systems in this manual consist of a lining fixed to furring channels that are supported by structural framing. The structural framing may be timber or steel joists, rafters or trusses, or a suspension system.

As a minimum requirement, framing shall be in accordance with the following applicable standards:

- AS1684 – Residential timber-framed construction.
- AS/NZS4600 – Cold-formed steel structures.
- AS3623 – Domestic metal framing.
- AS4055 – Wind loads for housing.
- The Building Code of Australia (BCA).

SoffitLine and Ceminseal Wallboard panels must not be fixed directly to the under side of roof framing or structural members. Furring must be used. Steel furring channels such as Rondo N°129 are recommended. Furring must have a minimum fixing face width of 35mm.

Framing set-out must be based on actual sheet lengths, with respect to the noted sheet tolerances. Correct design of the framework and sheet layout is important for the long term success of flush jointed installations.

Timber Framing

Timber shall be seasoned or have reached an equilibrium moisture content of 16% or less at the time of framing. Unseasoned timber is not recommended.

Steel Framing

The design and construction of the steel frames should be considered in conjunction with the advice from the manufacturer. In highly corrosive environments, appropriate measures should be taken to protect the frame from

corrosion. Refer to "Corrosivity Categories/Coastal Areas" (Page 5) in this guide.

Steel framing must be a minimum 0.55mm BMT to a maximum 1.6mm BMT. Do not fix Cemintel sheets to thicker cold rolled members or to hot rolled steel.

Cemintel recommends steel components manufactured by Rondo Building Services Pty Ltd, for our systems. Other brands of equivalent or better performance may be used. It is the responsibility of the manufacturer of the steel component to substantiate equivalent or better performance than the recommended Rondo component.

CONTROL JOINTS

To accommodate movement due to temperature and moisture effects, control joints in the framing are specified. Each system has a framing module, which indicates the spacing between framing control joints, and a panel module, for additional panel control joints.

Control joints must be provided in flush-set systems to allow for panel movement. They must be installed at the specified panel module and to coincide with control joints provided in the support framing.

Panel modules for exterior systems are given as multiples of single panel sizes and must not be formed with smaller panels that are joined.

PENETRATIONS

Penetrations in the Cemintel ceiling panels must be neatly cut using appropriate tools such as a saw, drill or hole saw. Penetrations should be prepared with a clearance of 5mm all around and the gap should be filled with sealant where acoustic performance is required.

INSULATION

Energy efficiency requirements for buildings are set out in the BCA as performance requirements and acceptable construction practices, and are dependant on geographical climate zones. Check with local building authorities for minimum insulation requirements.

For ceilings that form part of the building envelope, it is recommended that CSR Bradford insulation material is installed to meet energy requirements and improve occupant comfort. Insulation also improves the acoustic performance of the ceiling against outside noise. It is recommended that insulation values above the minimum be chosen for better energy conservation and occupant comfort.

In high humidity interior areas such as over pools, the design must be sufficient to ensure condensation does not occur.

For structures that do not require thermal insulation for energy efficiency, such as awnings and walkway canopies, it is recommended that insulation material is installed for condensation control. A suitable material is Bradford Anticon 55 roofing blanket.

The level of insulation provided in a ceiling is described by its R-value. The higher the R-value the greater the insulation provided.

Refer to The Gyprock Red Book® for thermal and acoustic performance values.

CORROSIVITY CATEGORIES/COASTAL AREAS

Corrosivity categories are as described in AS4312-2008-Atmospheric corrosivity zones in Australia. The code has methods for determining categories as well as maps and tables of major population centres. It is recommended that the building designer assess the site in accordance with the standard and local conditions.

For details on system requirements in different environments refer to Table 1. It is the building designer’s responsibility to determine the environmental zone, based on site conditions.

Due to limitations on the corrosion performance of steel framing, expressed joint systems are not appropriate in corrosivity Category C5.

The durability of the system can be increased by the additional treatment of steelwork, and by painting all exposed sealants to the sealant manufacturer’s recommendations. In corrosivity Category C4, sealants and other barriers are required to reduce the ingress of salt laden air.

The following is a summary of the BCA description.

C1: Very Low

Generally inside buildings, semi-sheltered locations away from marine or industrial influence, and some alpine regions.

C2: Low

Dry, rural areas, away from the coast or sources of pollution. Most areas of Australia at least 50 kilometres from the coast, which can extend to within one kilometre from quiet, sheltered seas. Most inland towns, such as Canberra, Ballarat, Toowoomba and Alice Springs, and suburbs of cities on sheltered bays (Brisbane, Melbourne, Hobart) that are more than one kilometre from the sea. Adelaide suburbs more than 6 kilometres from the coast in the southern suburbs, through to 3 kilometres from the coast in the northern suburbs.

C3: Medium

Coastal areas with low salinity, extended by factors such as wind, topography and vegetation. Sheltered areas such as Port Phillip Bay 50 metres from the shoreline to about one kilometre inland. Around less sheltered bays such as Adelaide to about 3 to 6 kilometres inland. Along ocean front areas with breaking surf and significant salt spray extending from about one kilometre inland to between 10 and 50 kilometres inland, depending on the strength of prevailing winds and topography. Includes much of the metropolitan areas of Wollongong, Sydney, Newcastle and the Gold Coast, most of the Yorke Peninsula South Australia, and from Victor Harbour to the Victorian border, extending between 30 and 70 kilometres inland. Urban and industrial areas with low pollution levels, and for several kilometres around large industries such as steelworks and smelters.

C4: High

Around sheltered bays up to 50 metres inland from the shoreline. Areas with rough seas and surf, extending from several hundred metres inland to about one kilometre inland and depends on winds, wave action and topography. Up to 1.5 kilometres downwind of large industrial plants.

C5: Very High

Offshore and on the beach front in regions of rough seas and surf beaches, and inland for several hundred metres, e.g. around Newcastle extending over half a kilometre from the coast. Aggressive industrial areas where the environment may be acidic with a pH of less than 5.

Table 1: System Requirements for Corrosive Environments

Corrosivity Category (AS4312-2008)	Exposed Head Screws	Countersunk Screws	Recommended Joint Type
C1 : Very Low C2 : Low	Class 3	Class 3	Flush-set, Expressed or Expressed with Sealant
C3 : Medium	Class 3	Class 3	Flush-set, Expressed or Expressed with Sealant
C4 : High	Class 4	Class 3	Flush-set or Expressed with Sealant
C5 : Very High	Not Suitable	Class 4	Flush-set

INDOOR POOL DESIGN CONSIDERATIONS

Consideration should be given to the corrosive environment around indoor swimming pools.

Measures should be implemented to avoid possible corrosion of the ceiling framing components and fixings from corrosive chemicals and moisture that may be present in the ceiling space.

In locations subject to excessive humidity and varying temperature range, Cemintel recommends the use of expressed joint ceiling systems only.

BUILDING RENOVATIONS

When undertaking building renovations, remove all linings from the original framing. Ensure the condition of the framing is in accordance with current applicable requirements. Install additional framing where required as per details in this publication.

PAINTING

All products should be painted within three months of delivery to site. Cemintel recommends a minimum of two coats of appropriate acrylic paint be applied to the paint manufacturer's specifications. A priming coat may also be required. Refer to paint manufacturer's recommendations.

Where Cemintel products are exposed to the elements for more than three months from delivery, Cemintel recommends the application of a priming coat before applying the decorative coatings.

For ceilings over pools, a paint system resistant to the chemical atmosphere is required. Dulux recommends a three coat system of Sealer Binder and ENVIROPOXY™ WBE near chlorinated and saltwater pools. The paint manufacturer, instructions should be followed in all cases.

Prior to the application of the external coating, wash down exposed surfaces with clean fresh water to remove salt spray build-up from boards and fixings. Boards must be allowed to dry before coating.

MAINTENANCE

Cemintel SoffitLine and Wallboard panels have properties which make them very durable, including:

- Moisture resistance;
- Fire resistance; and
- Termite resistance.

The durability of the Cemintel Ceiling systems can be enhanced by periodic inspection and maintenance. Inspections should include examination of the coatings, flashings and seals. Paint finishes must be maintained in accordance with the manufacturer's recommendations.

Any cracked or damaged finish or seals which would allow water ingress must be repaired immediately by recoating or resealing the effected area. Any damaged sealants, flashings or sheets must be replaced as for new work.

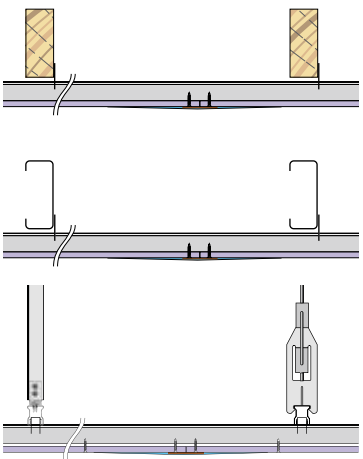
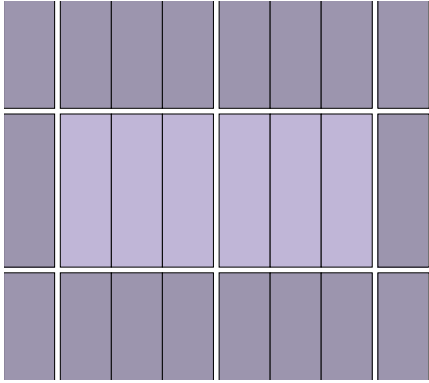
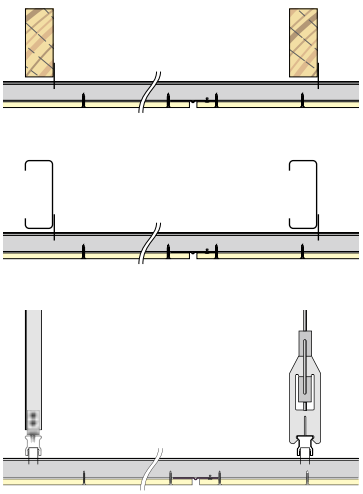
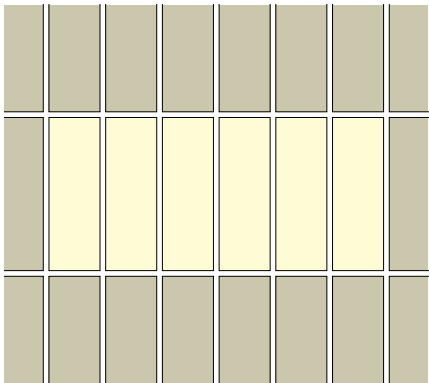
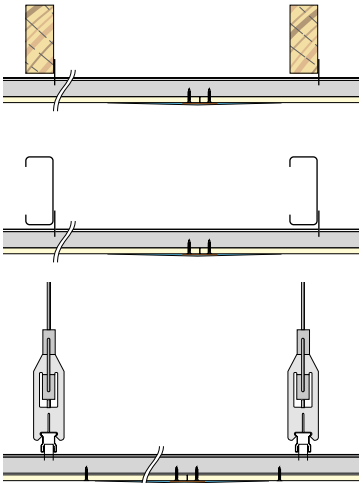
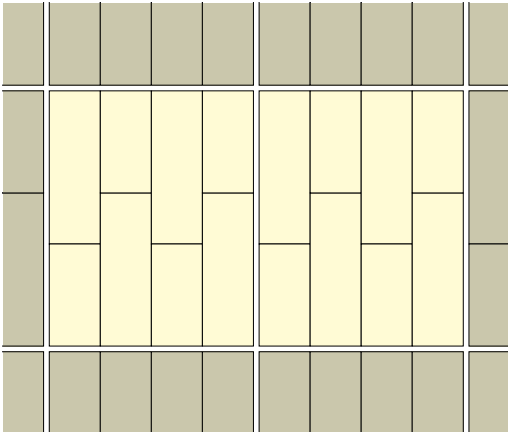

CEILING SYSTEM SELECTION

Framing & Jointing Type	Sheet Module Layout	Features & Applications
SOFFITLINE CEILING SYSTEMS – EXTERIOR CEILING WITH FLUSH-SET JOINTS		
		<p>Features</p> <ul style="list-style-type: none"> • 6mm SoffitLine recessed edge lining • Flush-set joints • Furring channels fixed to timber or steel joists, trusses or suspension system • Sheet module size up to 3.6 x 3.6m • Framing control joint module size up to 7.2 x 3.6m <p>Typical Applications</p> <ul style="list-style-type: none"> • Retail awnings • Verandas and balconies • Carports • Eaves <p>For detailed information, refer to page 14.</p>
EXTERIOR CEILING SYSTEMS WITH EXPRESSED JOINTS		
		<p>Features</p> <ul style="list-style-type: none"> • 6 or 9mm CeminSeal Wallboard (SE) square edge sheets • All joints expressed – may be with or without sealant depending on application (refer to Table 1) • Furring channels fixed to timber or steel joists, trusses or suspension system • Sheet module size up to 1.2 x 3.6m • Framing control joint module size up to 7.2 x 3.6m <p>Typical Applications</p> <ul style="list-style-type: none"> • Industrial awnings • Car park canopies • High-rise balconies • Carports <p>For detailed information, refer to page 18.</p>
INTERIOR CEILING SYSTEMS WITH FLUSH-SET JOINTS		
		<p>Features</p> <ul style="list-style-type: none"> • 6 or 9mm CeminSeal Wallboard (RE) recessed edge lining • Flush-set joints • Furring channels fixed to timber or steel joists, trusses or suspension system • Sheet module size up to 5.2 x 6.0m • Framing control joint module size up to 10.4 x 6.0m <p>Typical Applications</p> <ul style="list-style-type: none"> • Sports halls • Secure areas • Industrial storage areas <p>For detailed information, refer to page 22.</p>

COMPONENTS & ACCESSORIES

To guarantee performance, only approved fasteners should be used in these systems. Where nominal fasteners are required, Class 3 minimum finish products must be used.

In high corrosion zones, Class 4 or Stainless Steel fasteners are required. Supplied by others. Refer to "Corrosivity Categories/Coastal Areas".

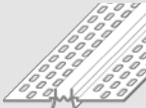
Product	Description	Size	Qty	Product Code
	<ul style="list-style-type: none"> • Sheet Fixing Screw – FibreTEKS™ CSK rib head, Phillips drive, Class 4 finish. Used to fix Cemintel sheets to steel framing of 0.5 to 1.0mm BMT 	10G-18 x 25mm	1000 (loose)	125651
			1000 (collated)	118225
		10G-18 x 30mm	1000 (loose)	125614
			1000 (collated)	118224
	<ul style="list-style-type: none"> • Horizontal Backing Strip – Used for backing horizontal expressed joints between panels. ExpressWall Backing Strip is manufactured from high tensile Colorbond steel, and is black in colour. 	60 x 1194mmL	1	21089
		60 x 2394mmL		21088
		60 x 2994mmL		21087
	<ul style="list-style-type: none"> • Gyprock Acrylic Stud Adhesive – Coloured blue for easy identification. It can be used on both timber and steel in temperatures not less than 5°C. Contact surfaces must be free of oil, grease or other foreign materials before application. The adhesive is applied with a broad knife. This product is suitable for use with pre-painted metal battens and some treated timbers. Always follow directions on packaging when using CSR stud adhesive. 	5.5kg bucket	1	10091
		1kg bucket	1	10090
		900g sausage	1	88618
	<ul style="list-style-type: none"> • Gyprock Paper Tape – For strong invisible jointing. 	75m	1	10589
		150m	1	10586
	<ul style="list-style-type: none"> • Soffitline External Jointing Compound – For quality flush jointed exterior finishing. 	15kg	1	85771
	<ul style="list-style-type: none"> • Soffitline Topping Compound – For quality flush jointed exterior finishing. 	15kg	1	95382
	<ul style="list-style-type: none"> • Sealant Bond Breaker Tape – Used behind sealant filled board joints. Tesa Multifoaam Tape N°7492, polyethylene closed cell foam tape. Self adhesive back. 	48 x 3mm x 25mL	1	13172
	<ul style="list-style-type: none"> • Flexible Sealant – Sikaflex®-PRO polyurethane sealant for sealed expressed joints, gaps around windows, doors and other penetrations. Paintable. Apply to manufacturer's specifications. 	310 ml tube	1 x Grey	11378
			1 x Black	39488
	<ul style="list-style-type: none"> • Sealant Primer – Sika® Primer-3 N. Should be applied to surfaces prior to sealant to improve the long-term performance of joints. Apply to manufacturer's specifications. 	250 ml	1	115227
	<ul style="list-style-type: none"> • H-Moulding – PVC moulding for sheet joints. 	2400mm	1	11253
		3000mm		11255
		3600mm		11256
	<ul style="list-style-type: none"> • Trim-Tex Expansion Joint – 72-093V PVC moulding has flanges that act as a trowel guide. Tear off strips act as a guide for taping knives and protect the centre from plaster during jointing. 	3000mm		10350
	<ul style="list-style-type: none"> • Trim-Tex Hideaway Expansion Joint – 72-2710 PVC moulding with a low profile that provides a full 6mm of movement. The soft centre "W" flexes as the structure expands and contracts. Tear off strips act as a guide for taping knives and protect the centre from plaster during jointing. 	3000mm		10351
	<ul style="list-style-type: none"> • Trim-Tex Shadow Bead – 72-5390 PVC moulding provides 6 x 10mm shadowline. Tear off strip acts as a guide for taping knives and protects the reveal from plaster during jointing. To suit 6 and 9mm sheet. 	3000mm		61021

Suspension Components

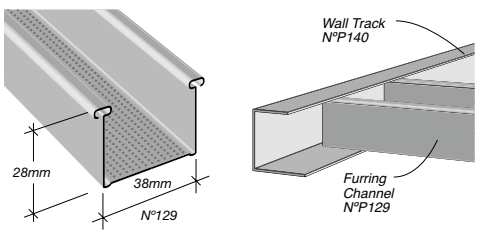
Part N°	Description	Product Code
P121	Suspension Rod (5mmø x 3600mm)	10389
P128	Top Cross Rail (38mm x 21mm, 0.75 BMT x 4800mm length)	10428
P129		
	Furring Channel – 3000mm	12122
	Furring Channel – 3600mm	10394
	Furring Channel – 4800mm	10464
	Furring Channel – 6000mm	10395
P138	Joiner – P129 to P129 Furring Channel	10400
P139	Joiner – P128 TCR to P129 Furring	10401
P140	Perimeter Trim (3000mm length)	10465
P188	Angle Bracket	10431
P226	Direct Fix Bracket for P129 to Timber/Steel – 75mm	10404
P247	Suspension Rod Bracket – Angle	10432
P272	Joiner – P128 to P128 Top Cross Rail	10409
P274	Suspension Rod Bracket – Straight	10410
P394	Direct Fix Bracket for P129 to Timber/Steel – 175mm	10435
P2534	TCR to Rod Clip – 100mm	10407

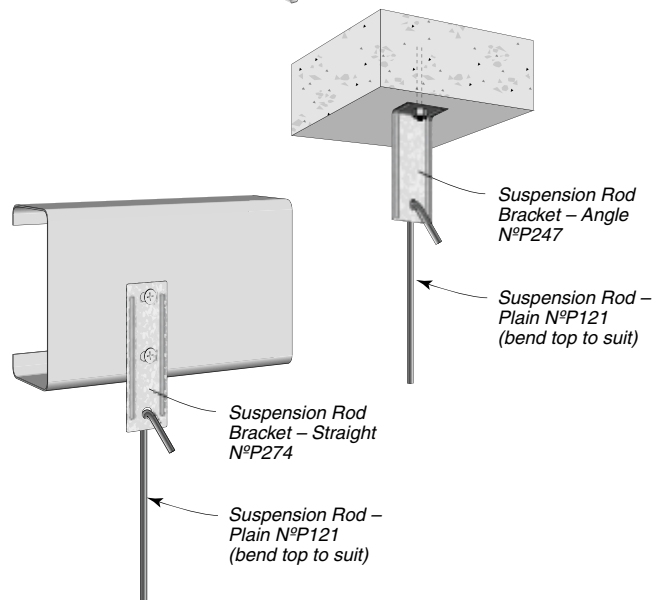
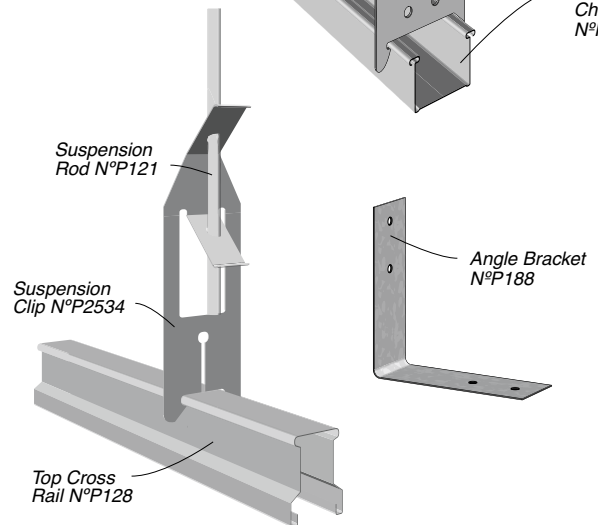
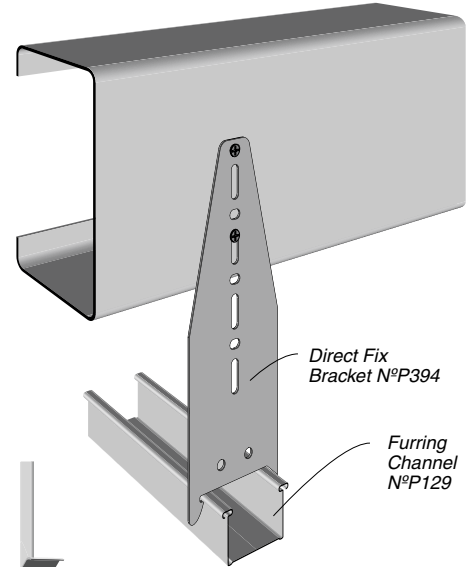
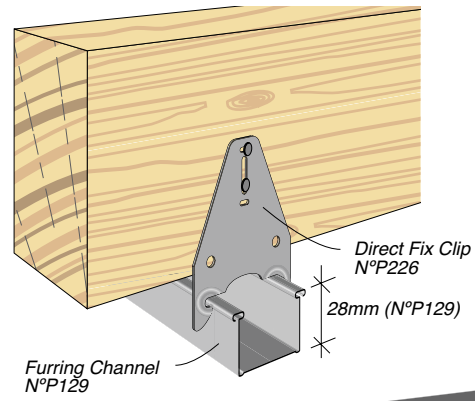
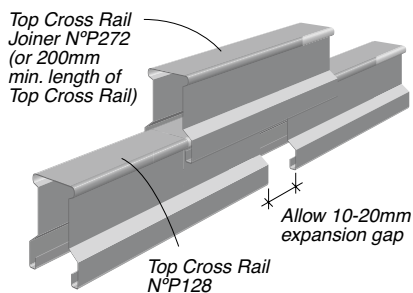
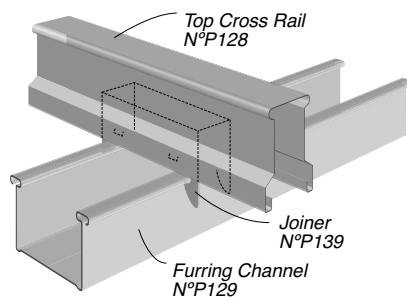
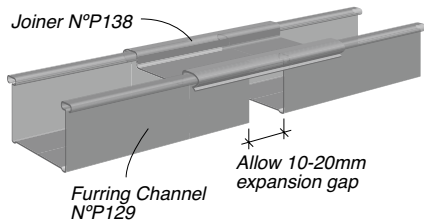

INSTALLATION PROCEDURE

FURRING CHANNEL FRAMING

The design capacities of Cemintel Ceiling systems are presented in two formats:

- Limit state format and for use with AS/NZS1170.2
- Wind Categories for use with AS4055

The building designer must calculate the appropriate loads or categories to select framing spans and spacing and sheet fixing spacings. Refer to Design Considerations for assumptions made for system design.

The furring channel capacities in the following tables have been calculated in accordance with AS4600 Cold Formed Steel Structures and are applicable for Rondo P129 channels only.

The connection of furring channels to structural framing is to be with Rondo P226 or P394. For exterior systems using Rondo Keylock suspension grid, a down strut is to be used adjacent to every hanger, refer to Table 4.

Where furring channel joiners are required within a framing module, they should be staggered between adjacent channels.

Table 2: Furring Channel Span and Spacing – Internal System – 6 or 9mm Cemintel Wallboard (RE)

Lining Product	Application	Furring Channel Spacing (mm)	Furring Channel Span (mm)	Panel Fixing Centres (mm)
Cemintel Wallboard	Interior air-conditioned	600	1200	300
SoffitLine	Interior high humidity	450	1200	300

Wind loads up to N3 (0.5kPa)

For Key-Lock suspension system details, refer to GYP548, Gyprock Commercial Installation Guide.

PANEL INSTALLATION

All SoffitLine and Wallboard panels are to be installed with long edges across the framing. Butt joints, where permitted, must be staggered a minimum of 600mm in adjacent sheets.

Avoid setting panel joints near openings such as skylights. Where these are unavoidable, they are to be positioned a minimum 200mm from corners of the openings.

Fasteners are to be positioned a minimum of 12mm from the edge of the sheet for recessed edges that are set, and 20mm from other edges. Fasteners are to be a minimum 50mm from sheet corners and are to be installed approximately 0.5mm below the sheet surface.

FIG 1: Fastener Positioning – Cemintel Wallboard

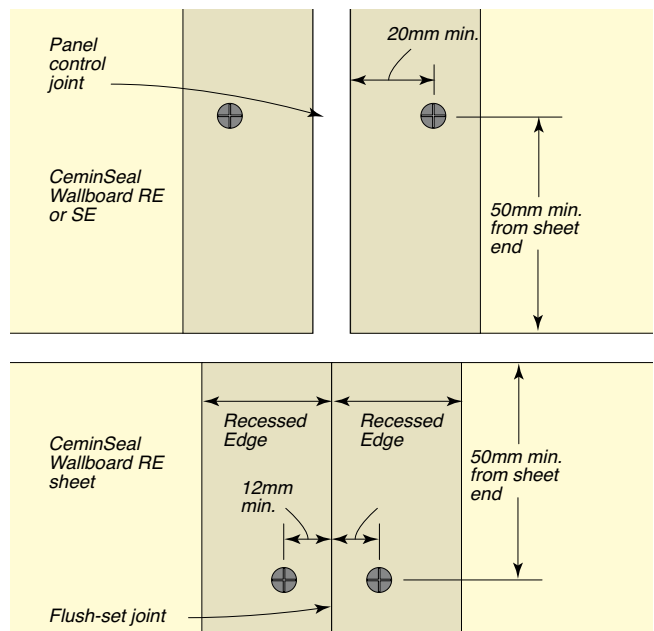

FIG 2: Fastener Positioning – Cemintel SoffitLine

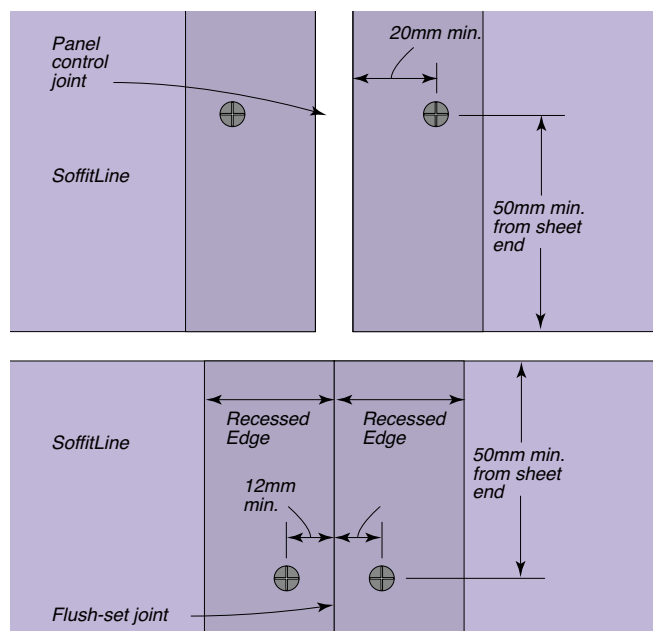

Table 3: Maximum Furring Channel Span and Sheet Fixing Centres (mm) – External Direct Fix Systems

Ultimate Design Wind Pressure kPa	Furring Channel Spacing (mm)			Sheet Fixing Centres (mm)
	300	450	600	
0.5	1610	1410	1290	300
1	1320	1120	920	300
1.5	1150	870	700	300
2	950	710	580	300
2.5	820	610	–	300
3	720	–	–	300
3.5	650	–	–	300
4	590	–	–	250

Table 4: Top Cross Rail (N°P128) Spacing, Downstrut Spacing and Sheet Fixing Centres – External Suspension Systems

Ultimate Design Wind Pressure kPa	Furring Channel Spacing (mm)	TCR Spacing (mm)	Maximum Downstrut Spacing (mm)	Sheet Fixing Centres (mm)
0.5	600	1150	1090	300
1	450	900	870	300
1.5	450	600	890	300
2	300	600	740	300
2.5	300	600	630	300
3	300	450	690	300

Maximum drop 1200mm soffit to Top Cross Rail (refer to FIG 20)

Table 5: Furring Channel Spans and Sheet Fixing Spacing for Residential Buildings – Cpn = 1.0

Wind Category AS4055	Corner Zones (K _i = 1.5)			Other Zones			
	Furring Channel Spacing (mm)		Sheet Fixing Centres (mm)	Furring Channel Spacing (mm)			Sheet Fixing Centres (mm)
	300	450		300	450	600	
N1	1360	1090	300	1520	1340	1140	300
N2	1180	890	300	1500	1140	940	300
N3/C1	880	660	200	1150	870	700	300
N4/C2	670	–	150	890	660	530	200
N5/C3	500	–	–	680	500	–	200

Table 6: Furring Channel Spans and Sheet Fixing Spacing for Residential Buildings – Cpn = 1.5

Wind Category AS4055	Corner Zones (K _i = 1.5)			Other Zones			
	Furring Channel Spacing (mm)		Sheet Fixing Centres (mm)	Furring Channel Spacing (mm)			Sheet Fixing Centres (mm)
	300	450		300	450	600	
N1	1120	840	300	1360	1090	890	300
N2	910	680	300	1180	890	720	300
N3/C1	670	–	200	880	660	–	300
N4/C2	–	–	–	670	–	–	200
N5/C3	–	–	–	500	–	–	200

Notes to All Wind Load Tables:

1. Tables are provided by Rondo and apply to Rondo framing products and to 6mm and 9mm thickness Cemintel products only.
2. Stated pressure is the Ultimate Design Wind Load, including all local factors.
3. Deflection limited to the lesser of L/600 under dead load, or L/200 under dead load plus service wind load.
4. Service wind load checked at 0.65 times the ultimate pressure.

Guide to Wind Load Tables

1. These tables are applicable to residential buildings within the scope of AS4055.
2. Local pressures may apply in corner zone **a = 1.2m** from building corners.

FIG 3: Two Sides Enclosed
(Refer to Table 5)
Cpn = 1.0

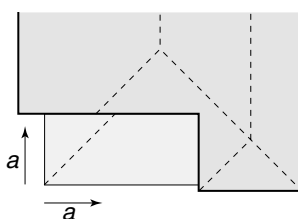

FIG 4: Unenclosed Verandah
(Refer to Table 6)
Cpn = 1.5

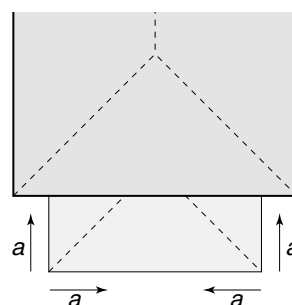
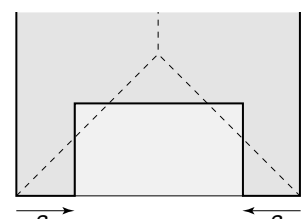

FIG 5: Three Sides Enclosed
(Refer to Table 6)
Cpn = ±1.2



INTERNAL CEILING SYSTEMS

Internal ceiling systems may be installed using the combination adhesive/fastener fixing system as detailed in FIG 6.

Alternatively the full fastener fixing system may be used as detailed in FIG 7. Fasteners must be spaced at 300mm maximum centres:

Table 2 details the maximum allowable furring channel span and spacing for CeminSeal internal ceiling systems.

FIG 6: Adhesive/Fastener Fixing System for Internal Flush-set Ceiling Systems

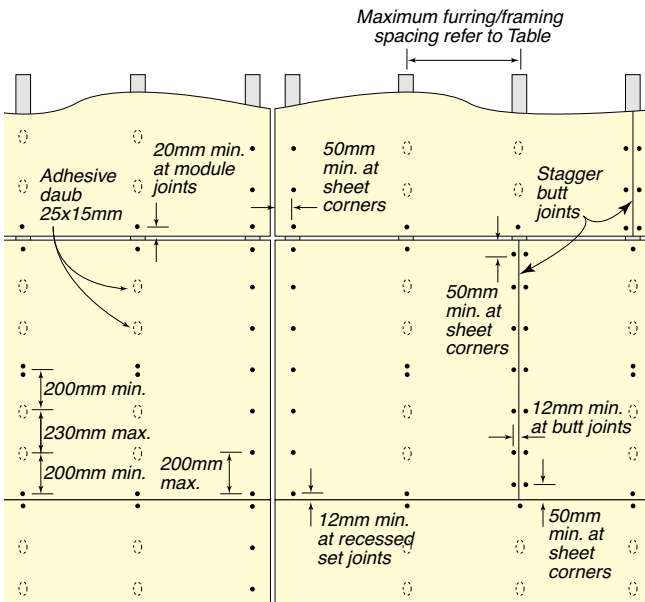
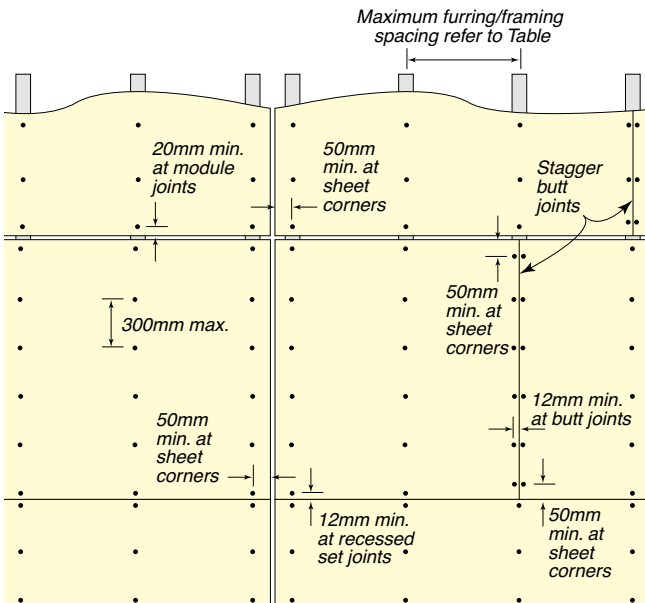

FIG 7: Fastener Fixing System for Internal Flush-set Ceiling Systems



EXTERNAL CEILING SYSTEMS

External ceiling systems must be installed using the all fastener fixing system as detailed in FIG 8 or FIG 9.

Table 3, Table 4, Table 5 and Table 6 detail the maximum frame/furring channel spacing and maximum fixing centres for SoffitLine and Ceminseal Wallboard external ceiling installations in various Wind Category and for various wind pressures.

FIG 8: Fastener Fixing System for External Flush-set Ceiling Systems

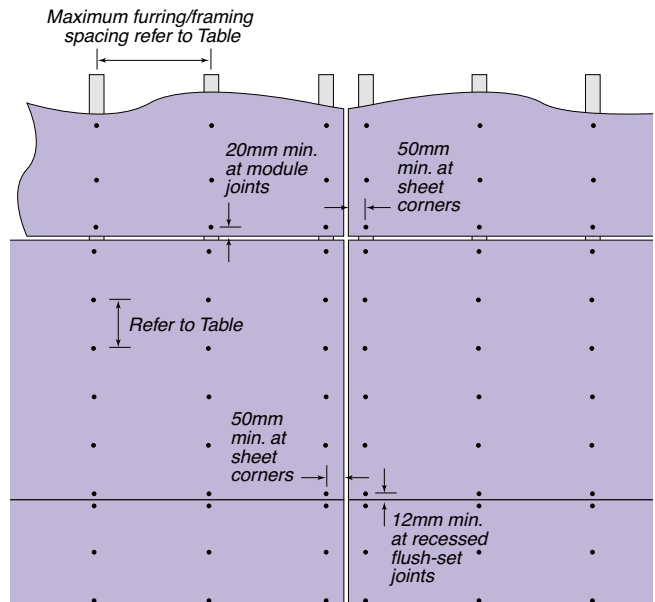
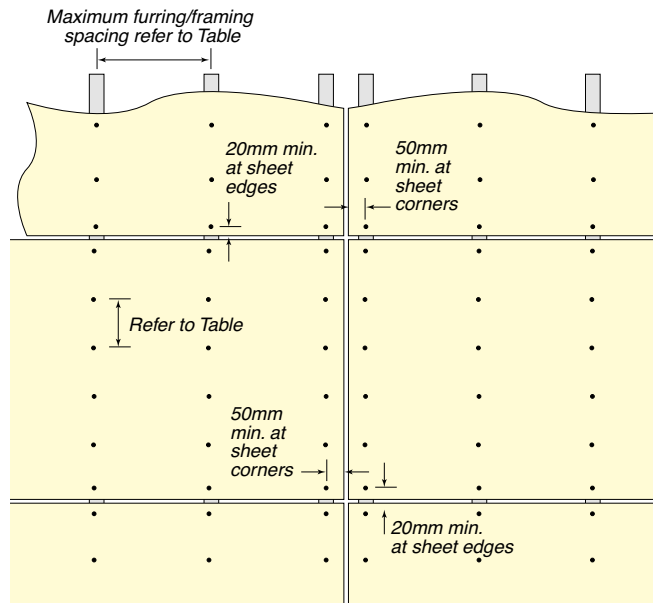

FIG 9: Fastener Fixing System for External Exposed Joint Ceiling Systems



INSTALLATION METHODS

HEALTH, SAFETY AND PERSONAL PROTECTION EQUIPMENT (PPE)

Panels contain silicas that are harmful if inhaled. Protective clothing and breathing equipment must be worn when cutting products. When cutting, drilling or grinding SoffitLine or Wallboard panels using power tools, always ensure the work area is properly ventilated. An approved dust mask (AS 1715 and AS 1716) and safety glass (AS 1337) must be worn. Cemintel recommends that hearing protection also be worn.

Safety Data Sheet information is available at cemintel.com.au hearing protection be worn where appropriate.

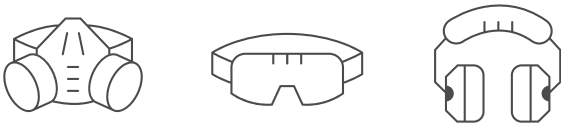

RECOMMENDED SAFE WORKING PRACTICES

Cutting Outdoors

1. Position cutting station so wind will blow dust away from the user or others in the working area.
2. Use a dust reducing plunge saw equipped with a dust extraction system.



Sanding/Drilling/Other Machining

When sanding, drilling or machining, you should always wear a P1 or P2 dust mask and warn others in the immediate area.

Important Reminders

1. **NEVER** use a power saw indoors.
2. **NEVER** use a saw blade that is not purpose-made for cutting fibre cement products.
3. **NEVER** dry sweep.
4. **ALWAYS** follow tool manufacturers' safety recommendations.
5. **ALWAYS** maintain tools in a clean condition.

Recommended Cutting Tools

Product	Description	Size	Quantity	Product Code
	Makita Plunge Saw Kit (1300W) includes 1400mm guide rail and bonus 165mm fibre cement saw blade – excellent for cutting cement based sheets	165mm	1	165485
	Makita 165mm Fibre Cement Saw Blade – ideal for use with the Makita Plunge saw and other 165mm circular saws fitted with vacuum extraction systems	165mmx20x4T	1	165486
	Dust Extraction			Supplied by others

INSTALLATION DETAILS FOR SOFFITLINE CEILING SYSTEMS – EXTERNAL CEILING WITH FLUSH-SET JOINTS

FEATURES

- 6mm SoffitLine recessed edge lining
- Flush-set joints
- Furring channels fixed to timber or steel joists, trusses or suspension system
- Sheet module size up to 3.6 x 3.6m
- Framing control joint module size up to 7.2 x 3.6m

TYPICAL APPLICATIONS

- Retail awnings
- Verandas and balconies
- Carports
- Eaves

FIG 10: Typical Layout for SoffitLine Ceiling System – External Ceiling with Flush-Set Joints

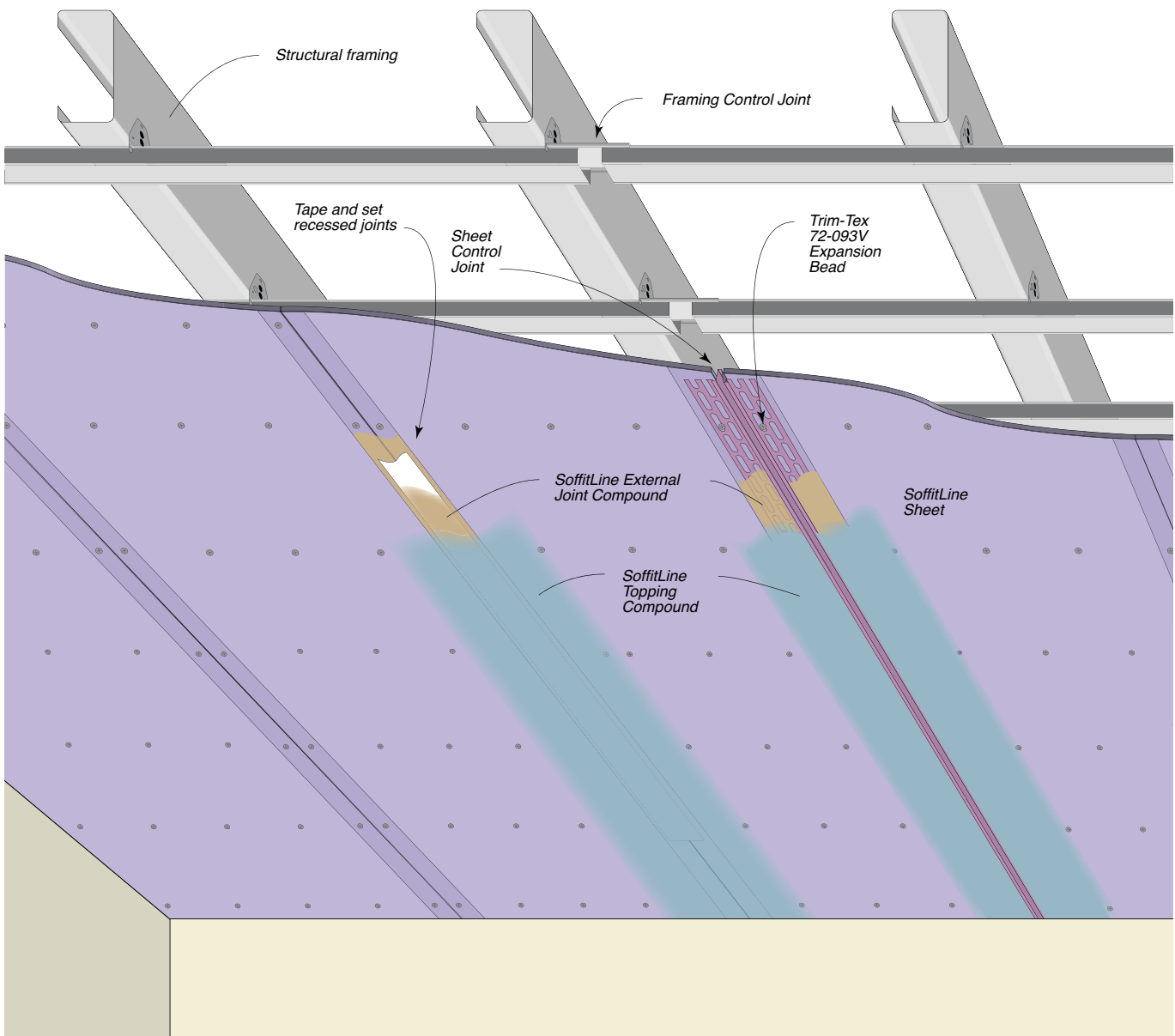
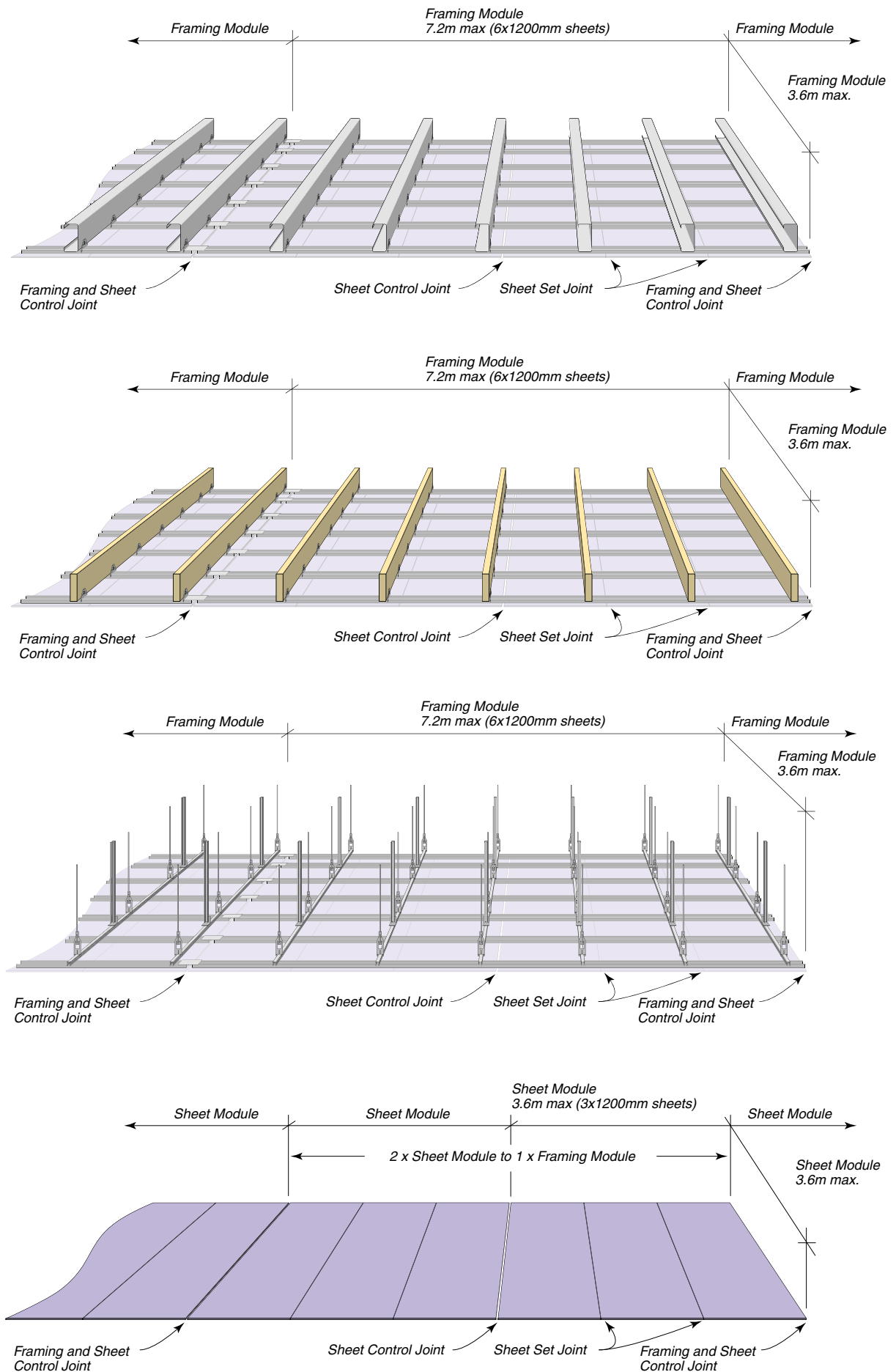

FIG 11: SoffitLine Ceiling System – External Ceiling with Flush-Set Joints



INSTALLATION DETAILS – SOFFITLINE CEILING SYSTEMS – EXTERNAL CEILING WITH FLUSH-SET JOINTS

FIG 12: Perimeter Detail

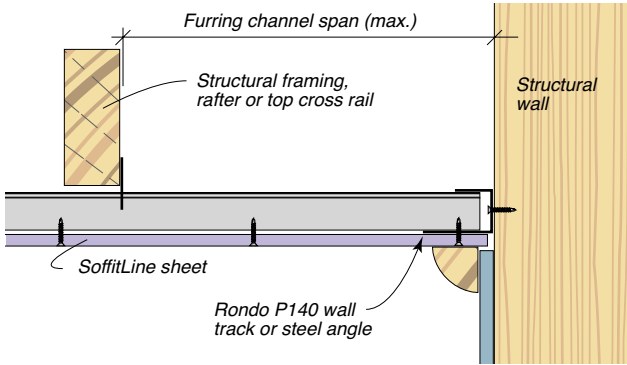

FIG 15: Perimeter Detail

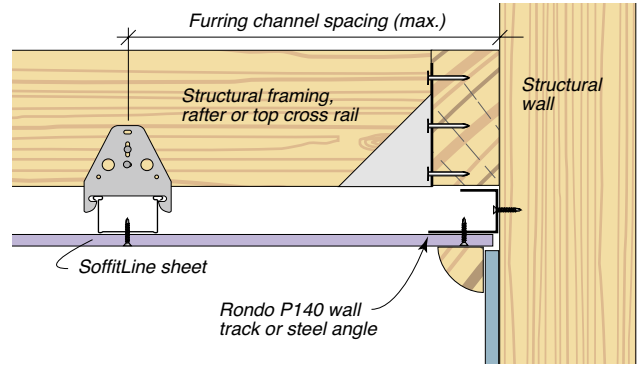

FIG 13: Perimeter Detail

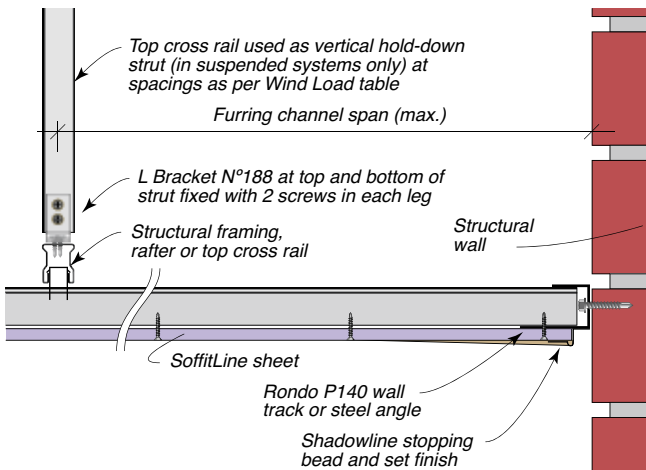

FIG 16: Perimeter Detail

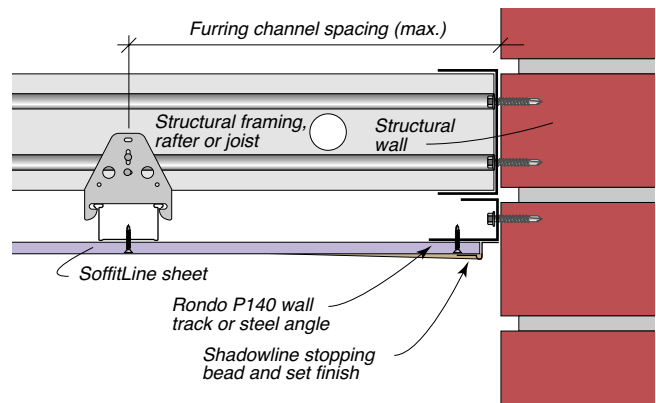

FIG 14: Framing & Sheet Module Control Joint

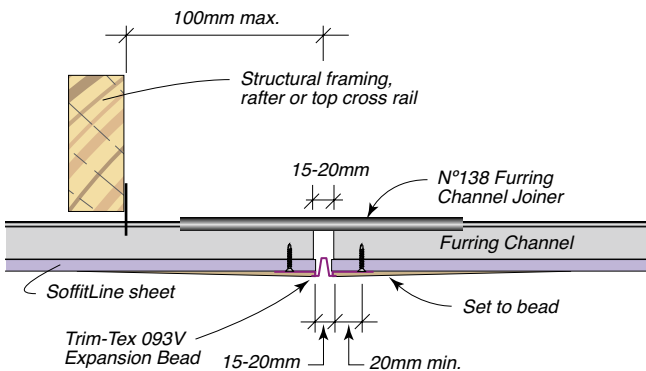

FIG 17: Framing and Sheet Module Control Joint

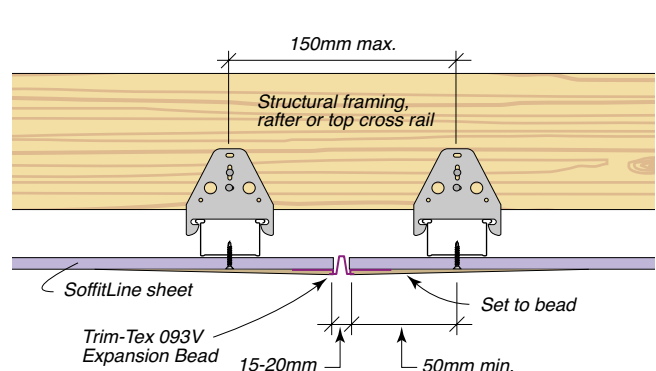

FIG 18: Sheet Module Control Joint

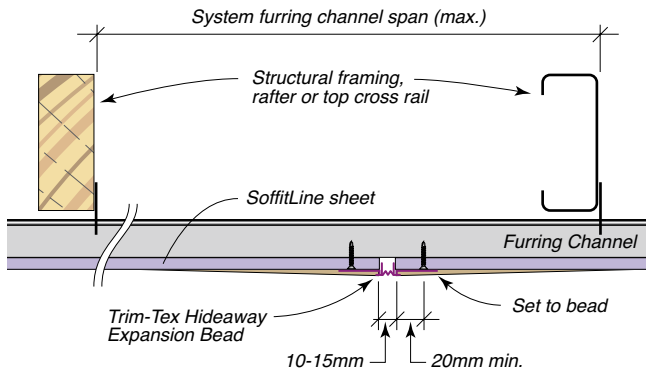

FIG 21: Sheet Set Joint

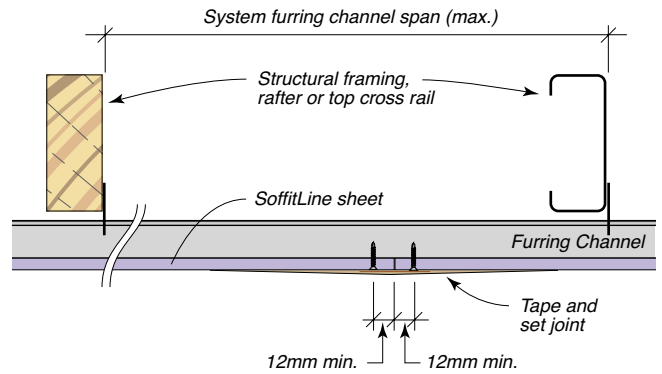

FIG 19: Joining of Furring Channel

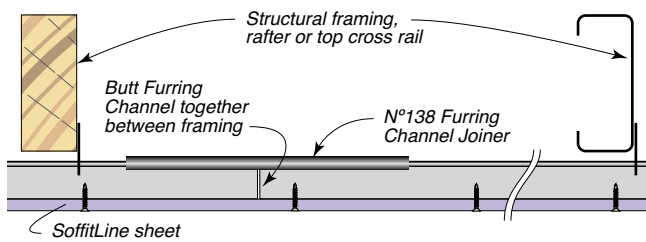

FIG 22: Flush-Set Jointing – External SoffitLine System Recessed Joint. (Refer to the JOINTING section in this guide for more detailed information)

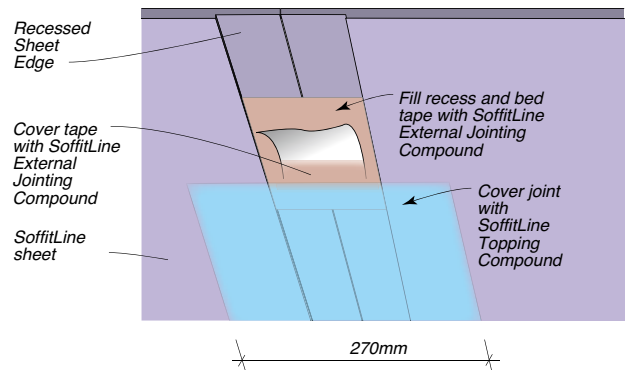
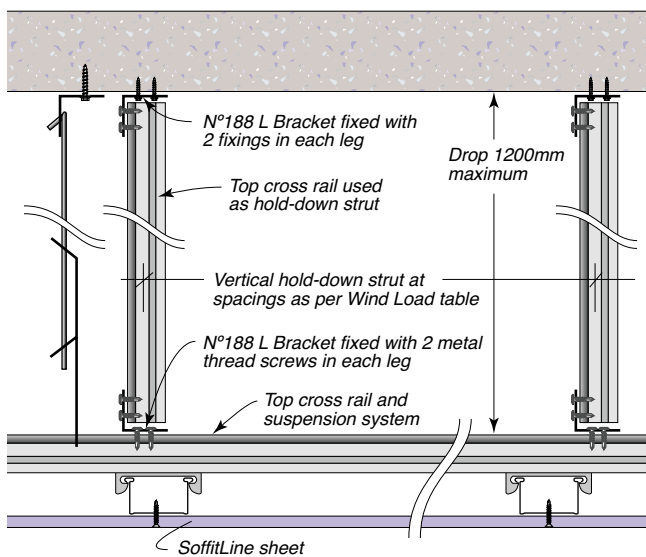

FIG 20: Hold-down Strut Detail – Suspended Ceiling System



Installation Tip:

Avoid the use of excess compounds to reduce sanding requirements.

INSTALLATION DETAILS FOR EXTERNAL CEILING SYSTEMS – WITH EXPRESSED JOINTS

FEATURES

- 6 or 9mm CeminSeal Wallboard (SE) square edge sheets
- All joints expressed – may be with or without sealant depending on application (refer to Table 1)
- Furring channels fixed to timber or steel joists, trusses or suspension system
- Sheet module size up to 1.2 x 3.6m
- Framing control joint module size up to 7.2 x 3.6m

TYPICAL APPLICATIONS

- Industrial awnings
- Car park canopies
- High-rise balconies
- Carports

FIG 23: Typical Layout for External Ceiling with Expressed Joints

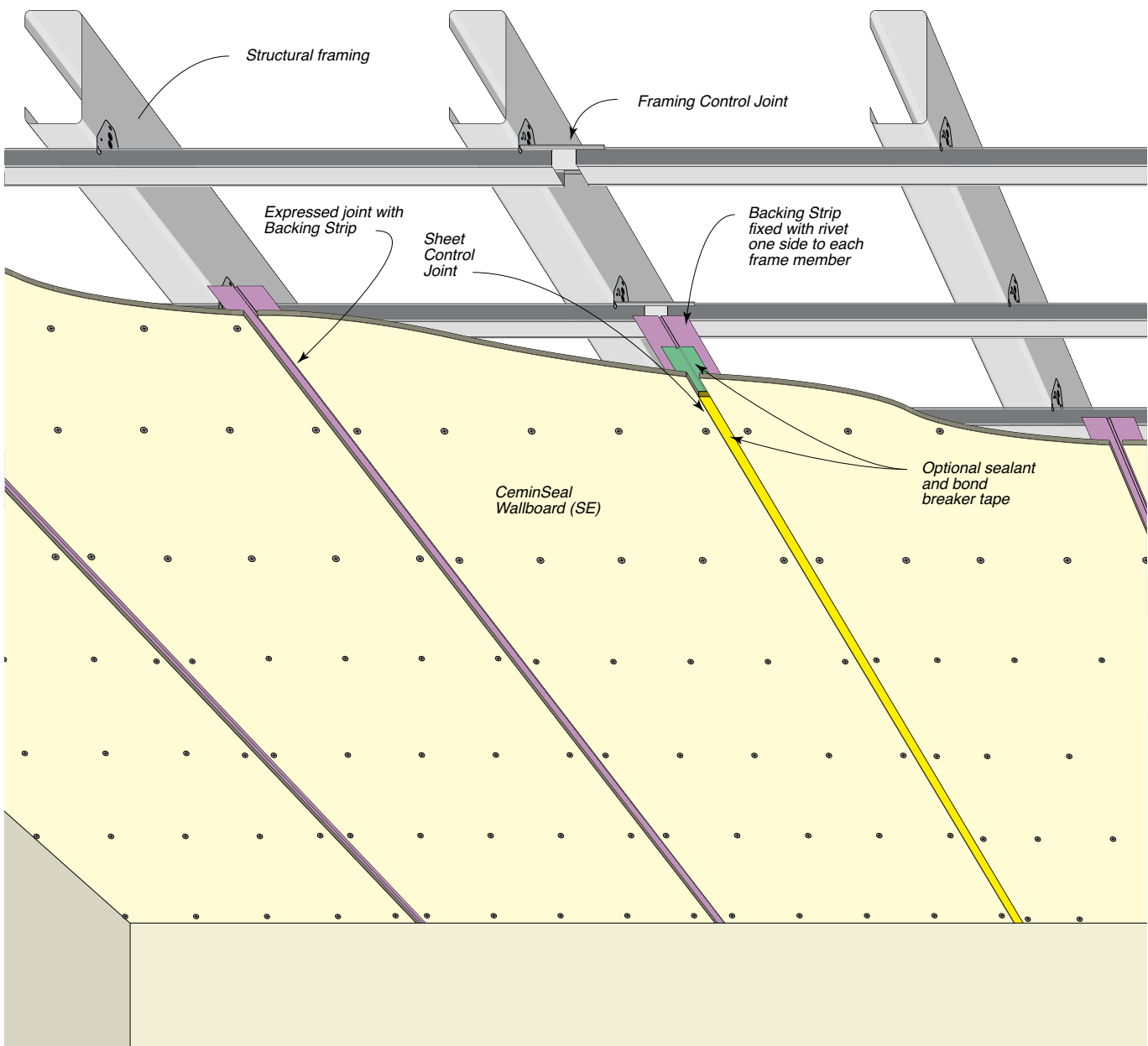
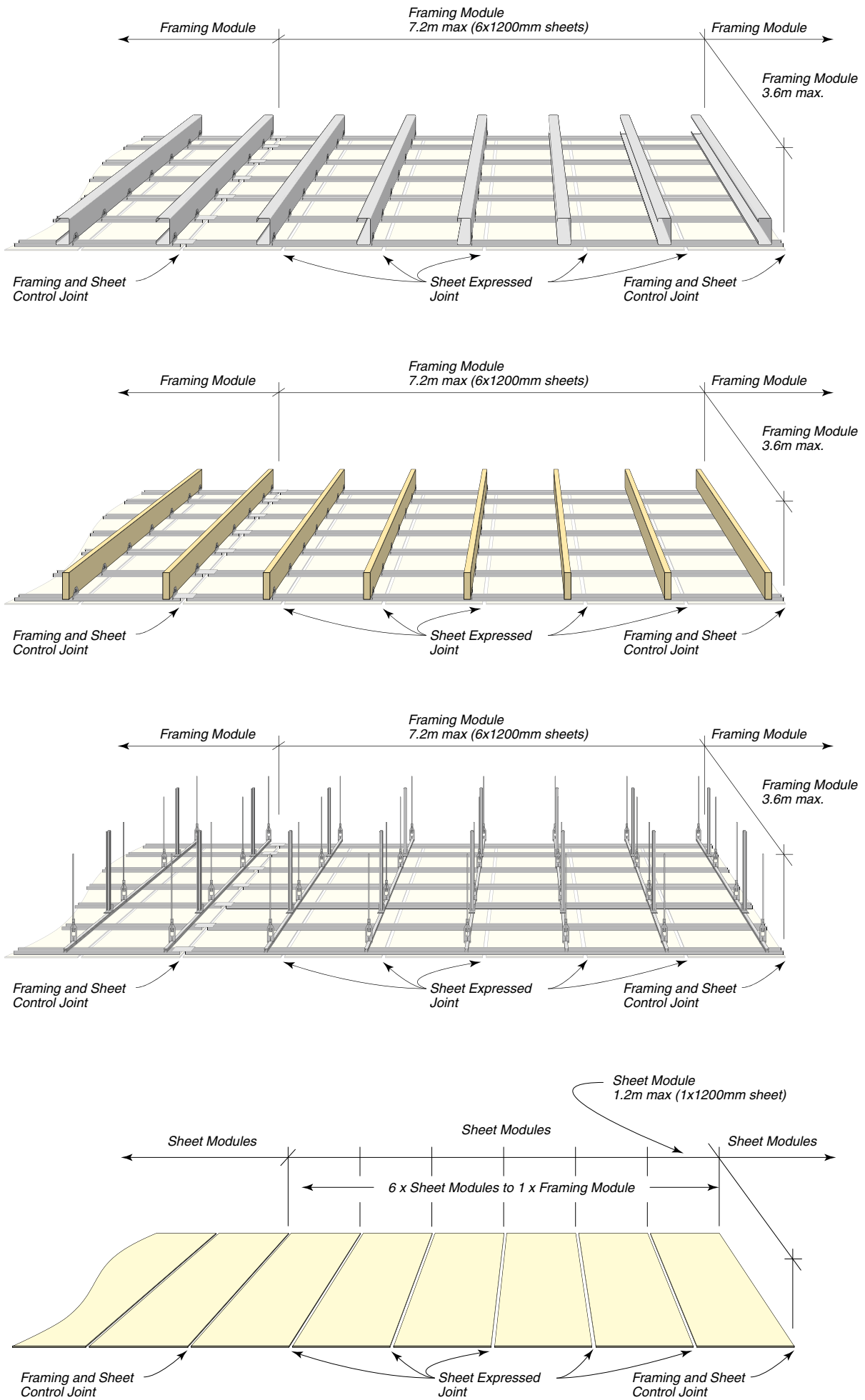

FIG 24: External Ceiling with Exposed Joints



INSTALLATION DETAILS – EXTERNAL CEILING SYSTEMS WITH EXPRESSED JOINTS

FIG 25: Perimeter Detail – Expressed Joint

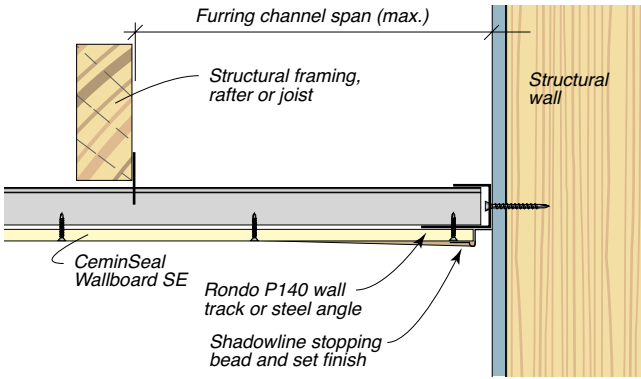

FIG 29: Perimeter Detail – Expressed Joint

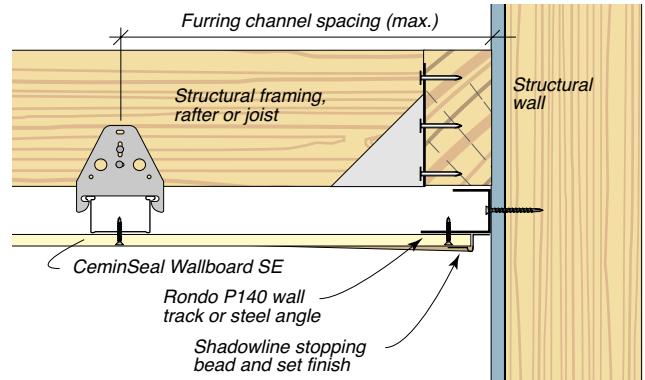

FIG 26: Perimeter Detail – Expressed Joint

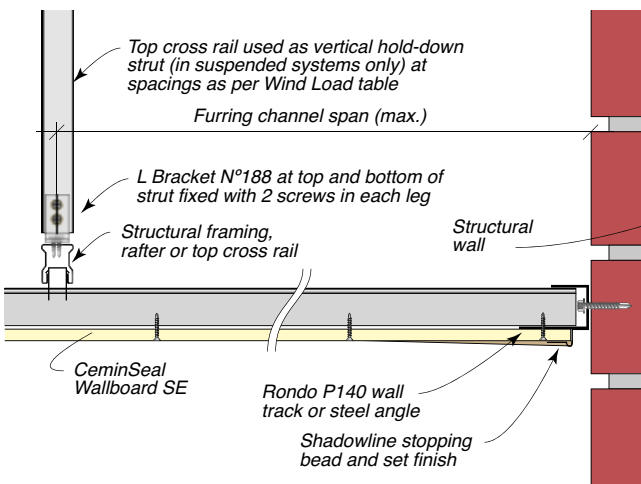

FIG 30: Perimeter Detail – Expressed Joint

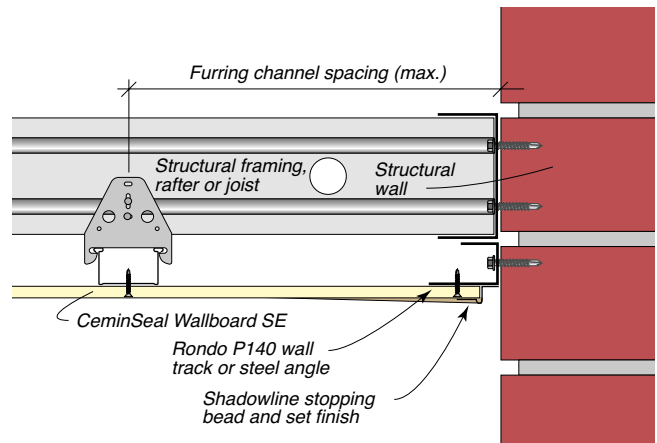

FIG 27: Framing & Sheet Module Control Joint – Expressed Joint

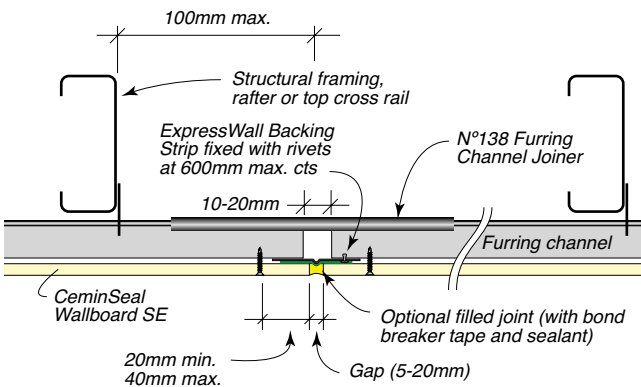

FIG 31: Framing and Sheet Module Control Joint – Expressed Joint

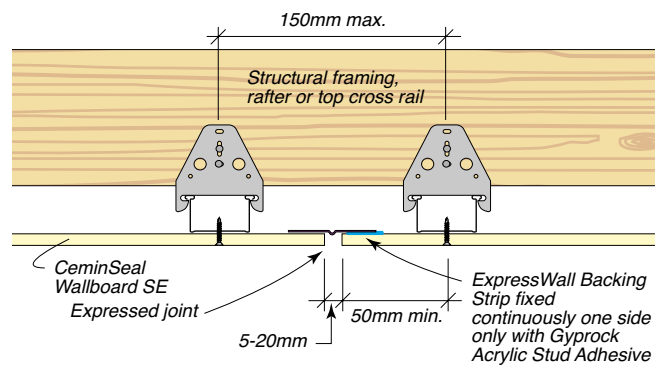

FIG 28: Sheet Module Control Joint – Expressed Joint

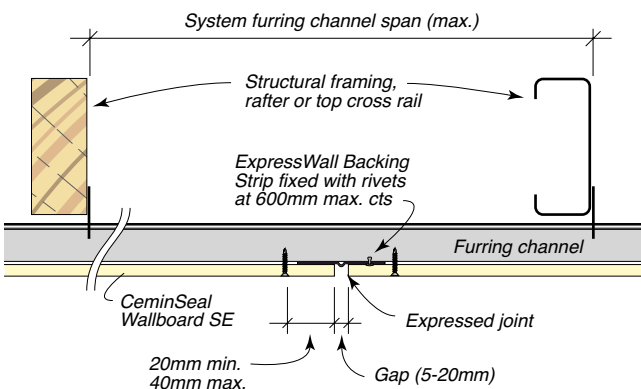

FIG 32: Framing and Sheet Module Control Joint – Expressed Joint – Alternative

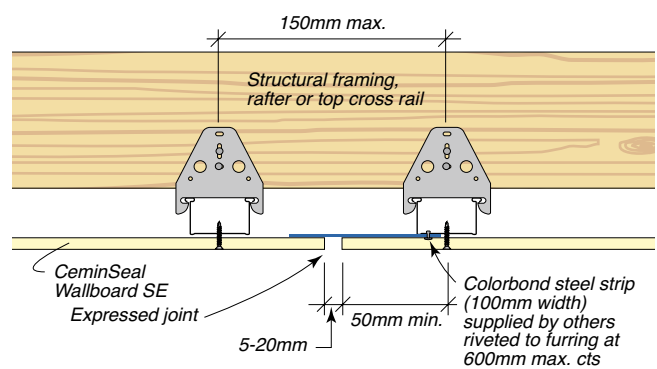

FIG 33: Sheet Module Control Joint – H-Mould Joint

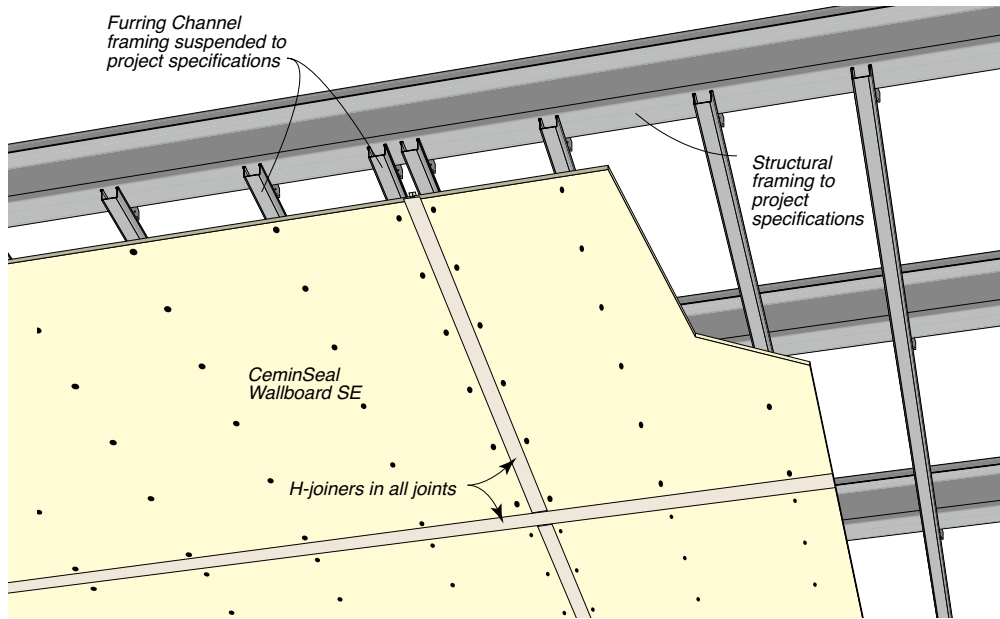

FIG 34: Sheet Module Control Joint – H-Mould Joint

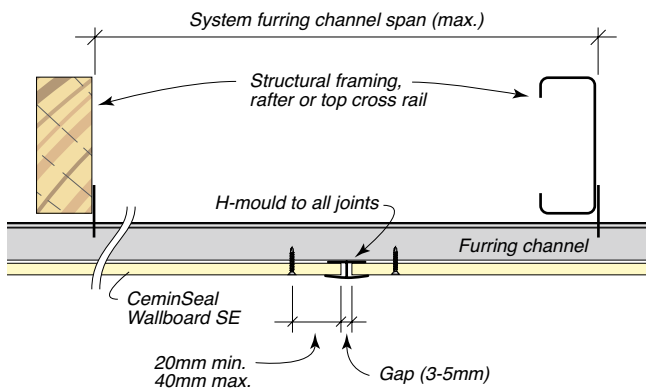

FIG 35: Framing and Sheet Module Control Joint – H-Mould Joint

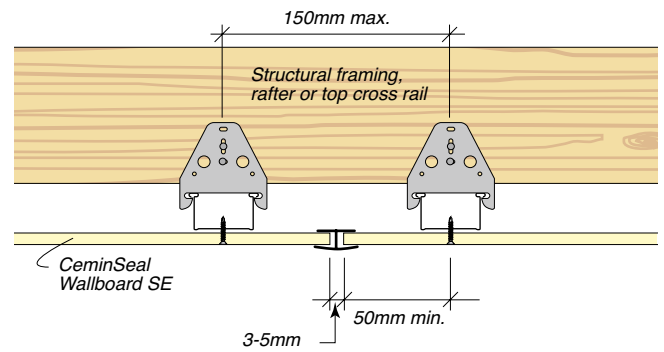

FIG 36: Typical Soffit/Fascia Junction Detail

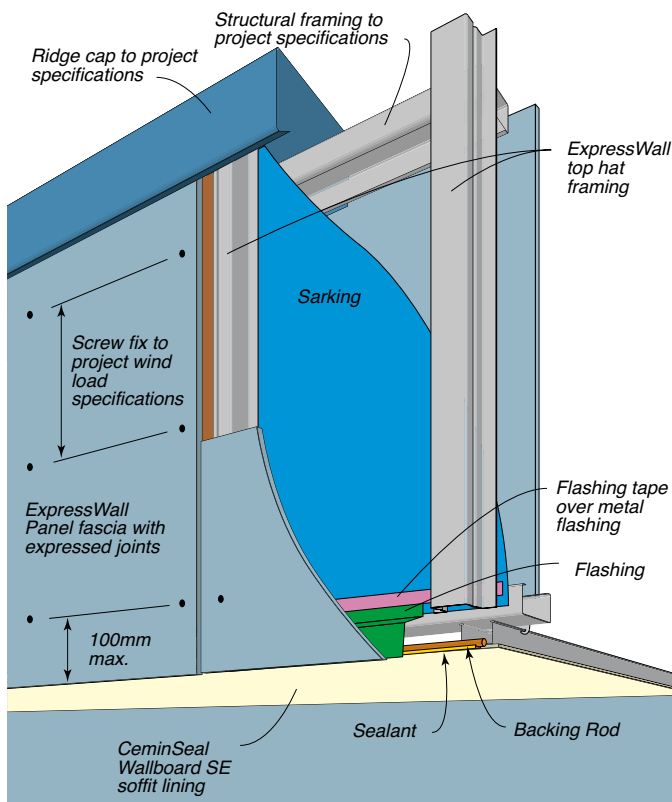
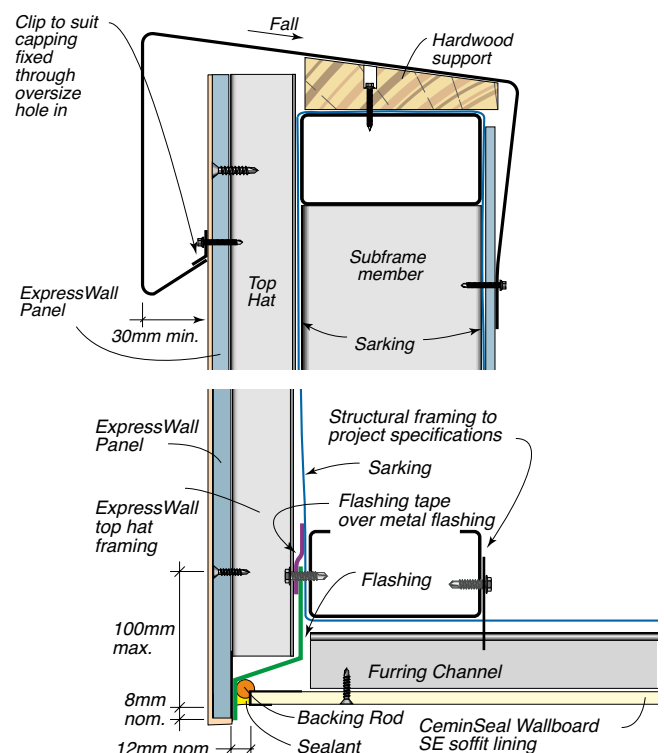

FIG 37: Typical Fascia and Soffit Detail



INSTALLATION DETAILS FOR INTERNAL CEILING SYSTEMS – WITH FLUSH-SET JOINTS

FEATURES

- 6 or 9mm CeminSeal Wallboard (RE) recessed edge lining
- Flush-set joints
- Furring channels fixed to timber or steel joists, trusses or suspension system
- Sheet module size up to 5.2 x 6.0m
- Framing control joint module size up to 10.4 x 6.0m

TYPICAL APPLICATIONS

- Sports halls
- Secure areas
- Industrial storage areas

FIG 38: Typical Layout for Internal Ceiling with Flush-Set Joints

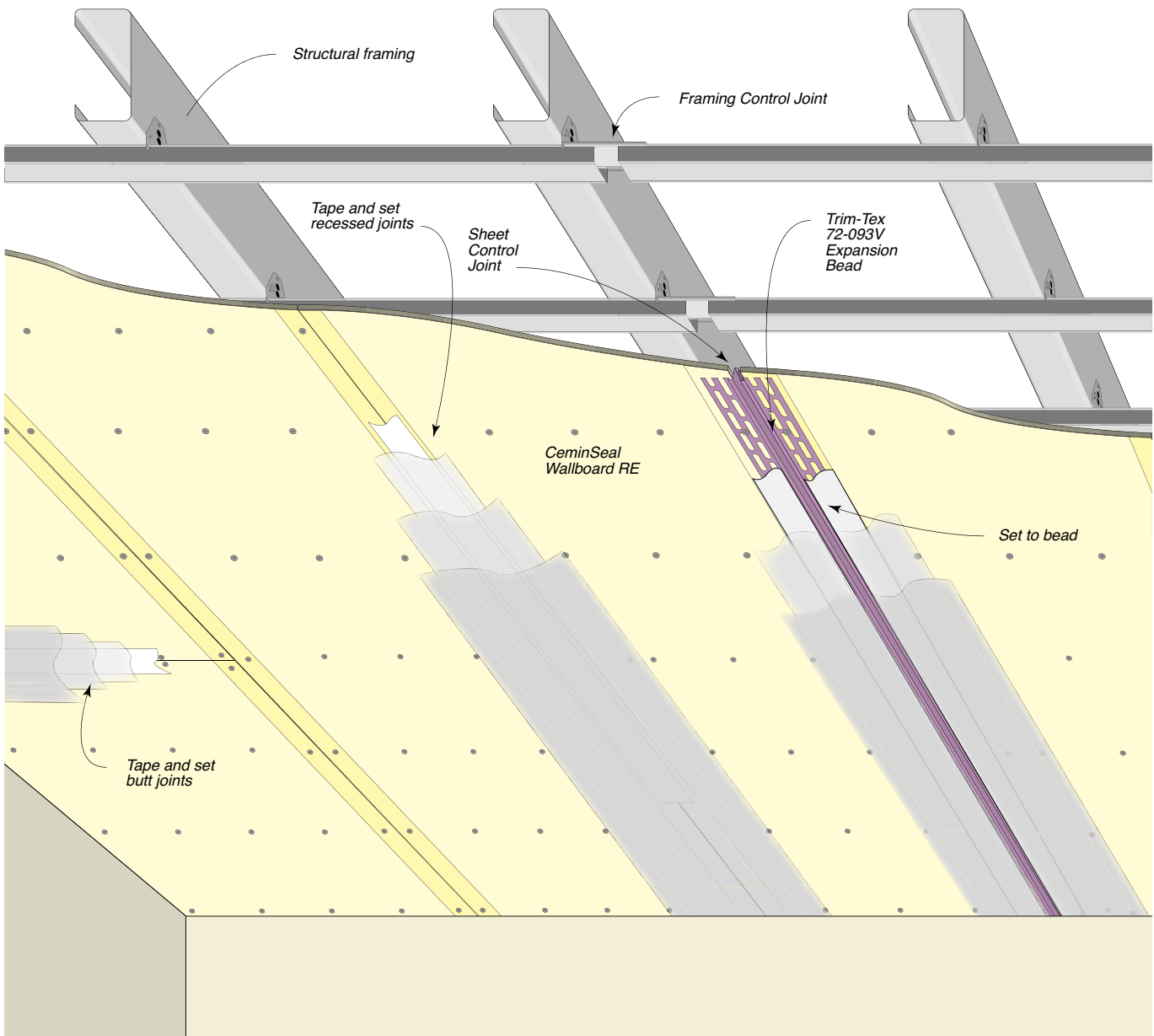
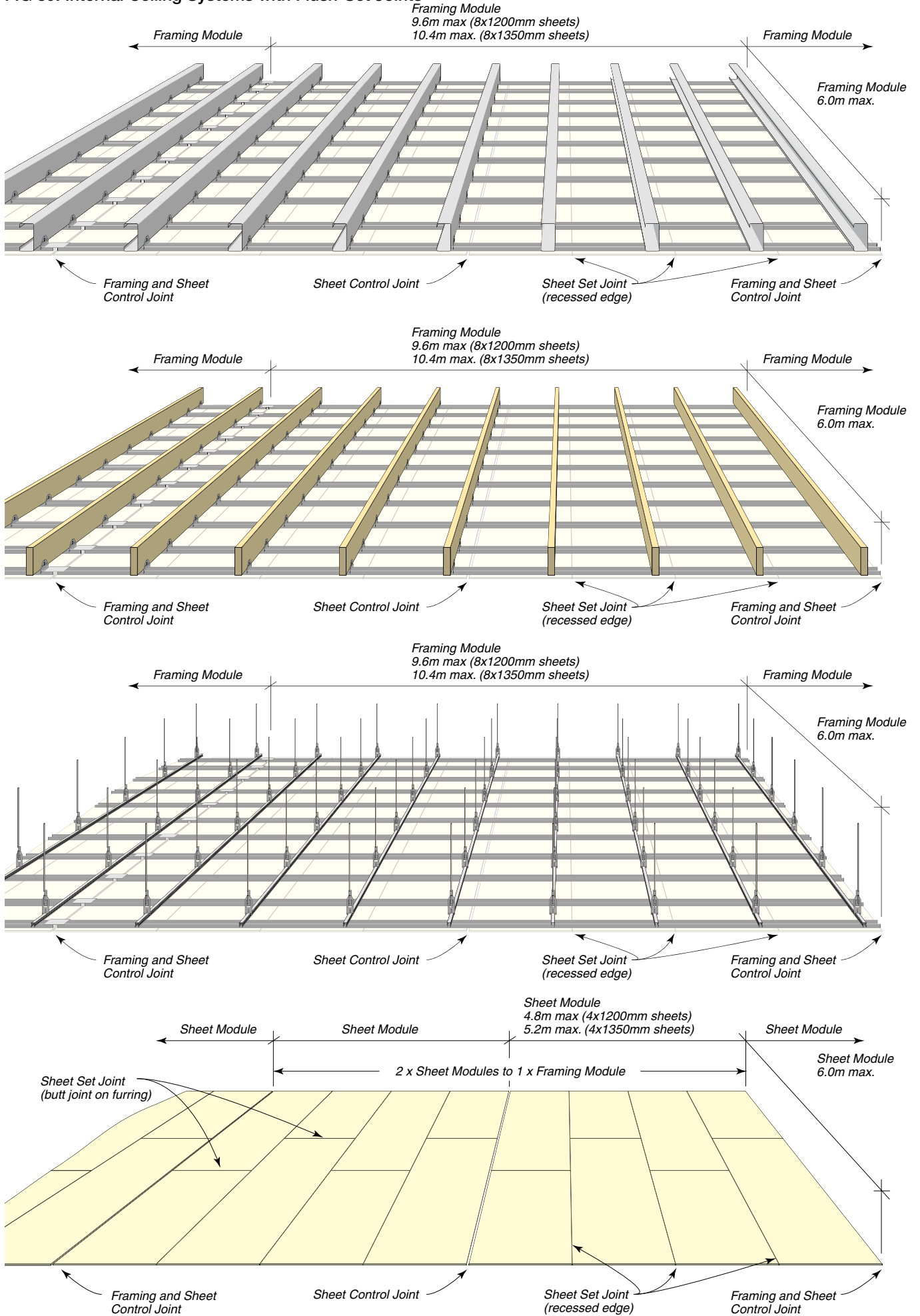

FIG 39: Internal Ceiling Systems with Flush-Set Joints



INSTALLATION DETAILS – INTERNAL CEILING SYSTEMS WITH FLUSH-SET JOINTS

FIG 40: Perimeter Detail

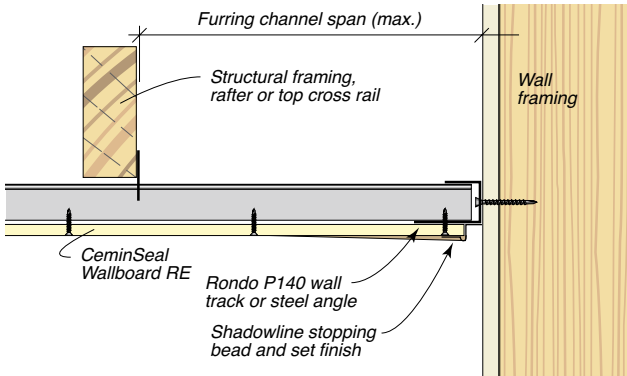

FIG 43: Perimeter Detail

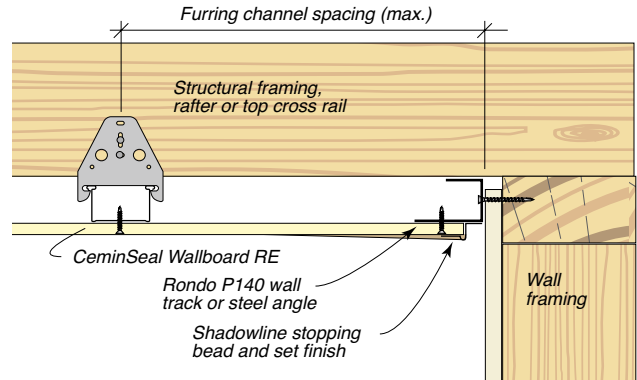

FIG 41: Perimeter Detail

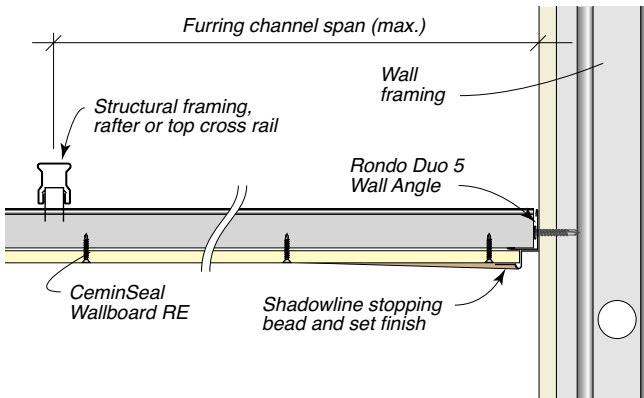

FIG 44: Perimeter Detail

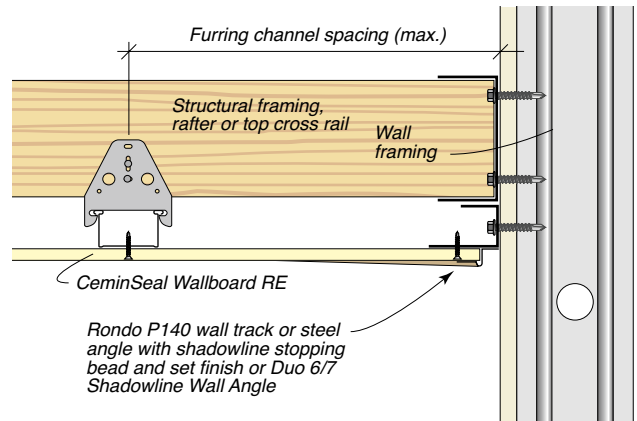

FIG 42: Framing & Sheet Module Control Joint

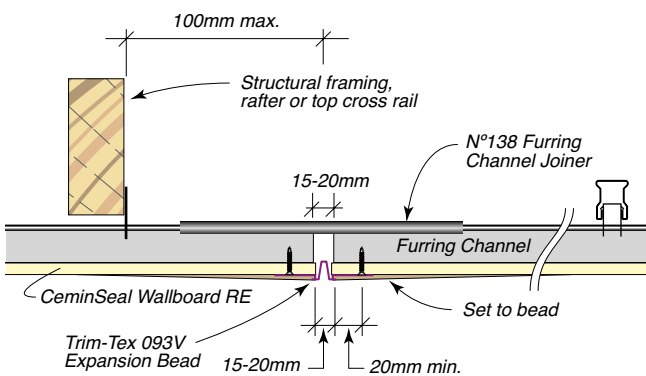

FIG 45: Framing and Sheet Module Control Joint

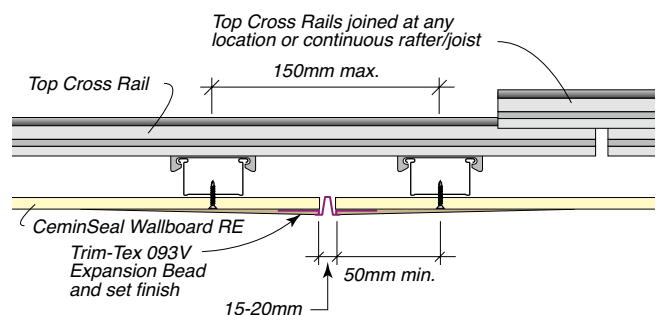

FIG 46: Sheet Module Control Joint

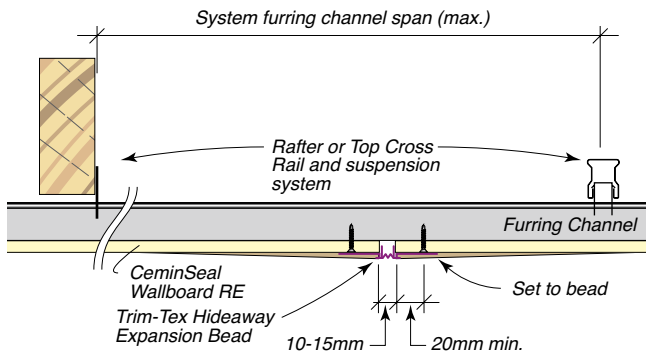

FIG 49: Sheet Set Joint (Butt or End Joint)

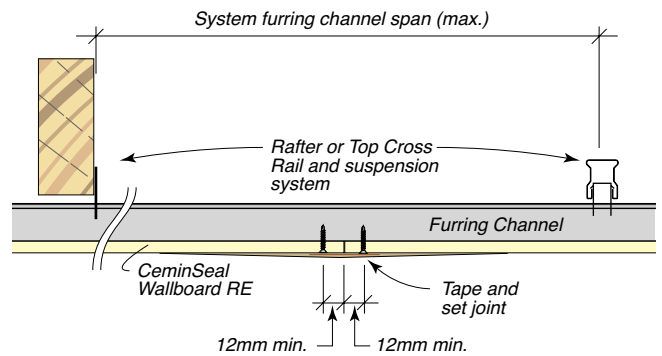

FIG 47: Flush-Set Jointing – Internal System Recessed Edge. (Refer to the JOINTING section in this guide for more detailed information)

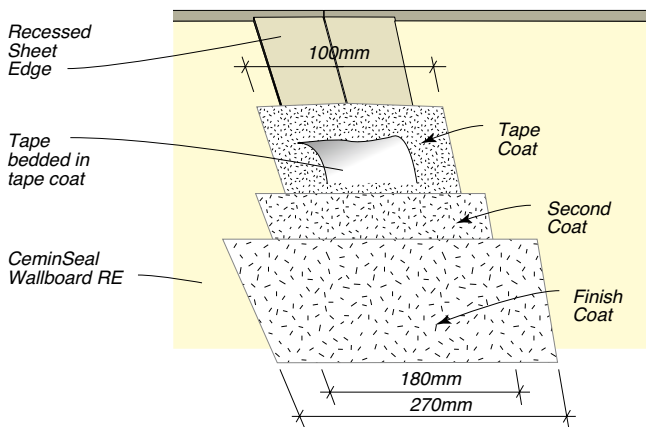

FIG 50: Flush-Set Jointing – Internal System Butt Joint. (Refer to the JOINTING section in this guide for more detailed information)

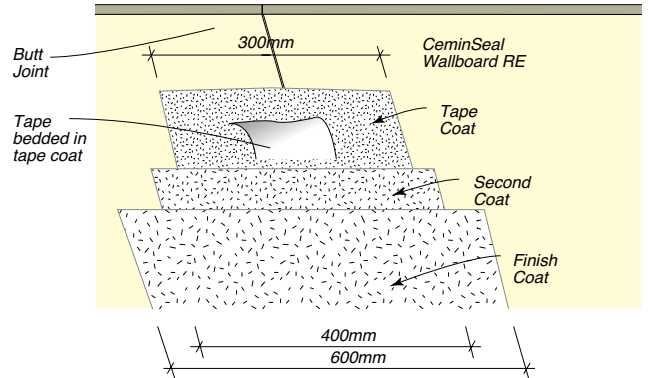
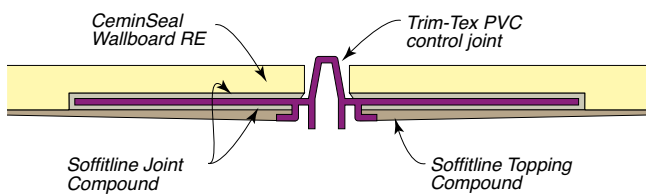

FIG 48: Control Joint Detail – External Application (Internal similar)



JOINTING

After SoffitLine or Ceminseal Wallboard sheets have been fixed the joints and/or fastener heads require stopping to provide a smooth surface for decoration.

INTERNAL SYSTEMS

Joints in CeminSeal Wallboard ceilings used in internal locations may be jointed using Gyprock plasterboard methods and compounds. Refer to GYP547, Gyprock® Residential Installation Guide for complete details. When using Wet Area Base Coat, remove excess material while it is wet to reduce sanding.

Tape Coat

1. Apply tape coat to both sides of the joint, bed the tape centrally over the joint and lightly cover with compound.
2. Cover all fastener heads with tape coat.
3. Allow tape coat to set/completely dry before proceeding.

FIG 51: Flush-Set Jointing – Interior System Recessed Edge

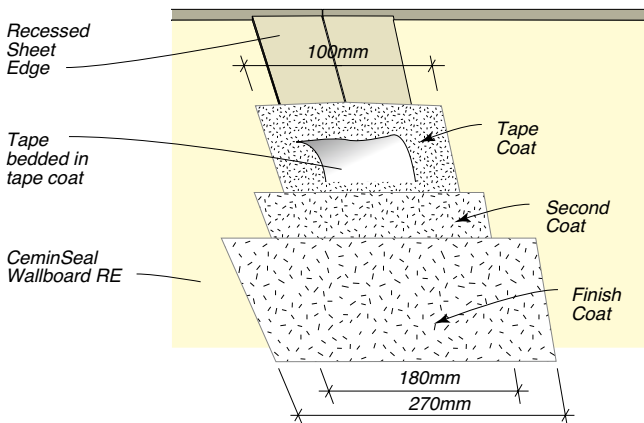

Second Coat

1. Apply a second coat to width as shown. Feather the edges with a trowel.
2. Cover fastener heads with a second coat, extending beyond the first coat by about 25mm.
3. Allow the second coat to set/completely dry before proceeding.

Finish Coat

1. Apply a finish coat centrally over the second coat, to width as shown. Feather the edges with a trowel. (If required, soften the outer edges of the compound with a damp brush before feathering).
2. Cover fastener heads with a finish coat, extending beyond the second coat by about 25mm. Ensure that the edges of the compound are neatly feathered and that there are no knife edge marks left in the final stopping.

Sanding

When set/completely dry, sand compound smooth with 150 grit paper or with 220 grit sanding mesh. Avoid any heavy pressure which might scuff the joints.

FIG 52: Flush-Set Jointing – Interior System Butt Joint

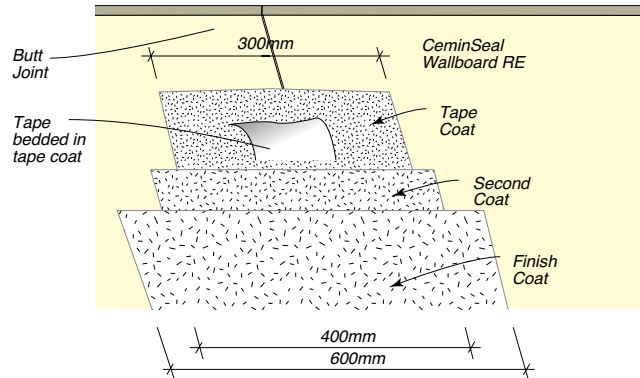

Table 7: Jointing System Selection – Internal Ceilings

Tape Coat	Second Coat	Finish Coat
Any of the following:	Any of the following: (*see note)	Any of the following:
Base Coat 20 Base Coat 45 Base Coat 60 Base Coat 90 Pre-Mixed Total Joint Cement Multi-Purpose Compound Wet Area Base Coat Easy-Flow Ultra-AP Total Coat-Lite (dry)	Base Coat 20* Base Coat 45* Base Coat 60* Base Coat 90* Pre-Mixed Total Joint Cement Multi-Purpose Compound Wet Area Base Coat Easy-Flow Ultra-AP Total Coat-Lite (dry)	Jointmaster Ultra-Top Pre-Mixed Total Joint Cement Multi-Purpose Compound Easy-Finish Easy-Flow Final Finish Ultra-AP Total Coat-Lite (dry)

* Setting compound. Do not use a setting compound over a drying type compound.

EXTERNAL SYSTEMS

Recessed joints in SoffitLine ceilings used in external locations must be set using SoffitLine external compounds and paper tape.

SoffitLine compounds are acrylic and have different sanding characteristics than plaster products, and require increased sanding effort. Care should be taken in the application of both jointing and topping compounds to minimise the use of excess material. This will result in little need for sanding.

RECESSED EDGES

Taping Coat

1. Fill recess evenly and fully with SoffitLine External Jointing Compound. Only the recess area should be filled; avoid spreading the compound over the face of the sheet
2. Bed in the paper tape centrally over the joint and cover lightly with compound.
3. Allow to dry completely, approximately 2–4 hours in warm conditions.

Second Coat

1. If required apply a second coat of SoffitLine External Jointing Compound to ensure tape is completely covered. Do not spread the compound wider than the recess. Feather edges whilst the compound is wet.
2. Allow compound to dry and harden thoroughly, approximately 2–4 hours in warm conditions.

Finish Coat

1. Scrape joint with a joint knife to remove any excess jointing compound.
2. Apply a thin coat of SoffitLine Topping Compound centrally over the joint, about 270mm wide. Ensure that the edges of the compound are neatly feathered to minimise sanding.

Fasteners

Fasteners may be coated with up to three coats of SoffitLine Topping compound. The fasteners must be driven just below the board surface so that a smooth finish can be achieved. Ensure that there are no knife edge marks left in the final stopping.

Sanding

With careful compound application, sanding should be minimal. When required, ensure the topping is dry, and sand smooth with 120 grit paper. Avoid any heavy pressure which might scuff the joints.

FIG 53: Flush-Set Jointing – External SoffitLine System Recessed Joint

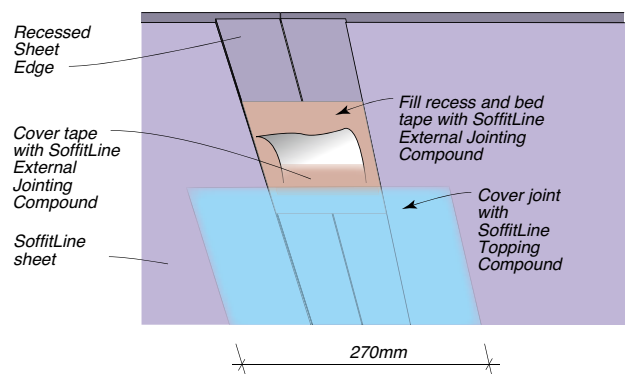

Installation Tip:

Avoid the use of excess compounds to reduce sanding requirements.

Table 8: Jointing System Selection – Exterior Ceilings

Tape Coat	Second Coat	Finish Coat
SoffitLine External Jointing Compound	SoffitLine External Jointing Compound	SoffitLine Topping Compound

Handling & General Care

Storage

All Cemintel panels must be stacked flat, clear of the ground and supported at 300mm maximum centres on a level platform. Panels must be kept dry, preferably stored inside the building. Panels must be dry prior to fixing, hence if it is necessary to store outside, the product must be protected from the weather.

Handling

Cemintel panels must be treated with care during handling so as to avoid damage to edges. Panels should be carried horizontally on edge by two people.

Penetrations

Penetrations in panels may be cut or drilled prior to installation. Cut from the back or drill from the front. Cut penetrations oversize by 8-10mm all around. Mask, prime and fill gaps with sealant in accordance with recommended methods and products.

Warranty

Both Cemintel SoffitLine and Cemintel Wallboard RE/SE panels have a product warranty of 25 years.

The full Cemintel product warranty is available for download at cemintel.com.au



Our Offices

Brisbane

768 Boundary Road
Coopers Plains QLD 4108

Sydney

376 Victoria Street
Wetherill Park NSW 2164

Melbourne

277 Whitehall Street
Yarraville VIC 3013

Adelaide

Lot 100 Sharp Court
Mawson Lakes SA 5095

Perth

19 Sheffield Road
Welshpool WA 6106

Hobart

11 Farley Street
Derwent Park TAS 7009

Darwin

Cnr Stuart Highway & Angliss
Street
Berrimah NT 0828

cemintel.com.au
1300 236 468

For Design and Technical Support:
DesignLink – 1800 621 117

Disclaimer: Information presented in this document is supplied in good faith and to the best of our knowledge, was accurate at the time of preparation. Products are subject to natural variation as part of the manufacturing process. Product images may vary from actual product in regard to colour and surface finish. The provision of this information should not be construed as a recommendation to use any of our products in violation of any patent rights or in breach of any statute or regulation. Users are advised to make their own determination as to the suitability of this information in relation to their particular purpose or specific circumstances. Since the information contained in this document may be applied under conditions beyond our control, no responsibility can be accepted by Cemintel, or its staff for any loss or damage caused by any person acting or refraining from action as a result of misuse of this information.