

CEMINTEL®



EXTERNAL CLADDING & EAVES LINING
Residential External Cladding System

TABLE OF CONTENTS

01 INTRODUCTION	2	Inspection, Repair and Maintenance	10
Introduction	2	Wash Down Process	10
02 PRODUCT OVERVIEW	3	05 COMPONENTS + ACCESSORIES	12
Panel Information	4	06 SYSTEM ENGINEERING, INSTALLATION & CONSTRUCTION DETAILS	15
Product Specifications	4	Design, Detailing and Performance	
Fire Resistance	4	Responsibilities	16
03 SYSTEM OVERVIEW	5	Wall Cladding	17
Applications	6	Joint Details	18
Advantages	6	Window Installation	20
04 DESIGN + AESTHETIC CONSIDERATIONS	7	Ceilings & Eaves	20
System Design	8	Ceilings	20
Framing	8	Eaves	20
Wall Wrap/Sarking Selection	8	Joint Details	22
Condensation	9	07 SAFETY, HANDLING, GENERAL CARE + WARRANTY	24
Cold Climates	9	Health, Safety and PPE	25
Coastal Areas	9	Safety, Handling and Maintenance	25
Insulation	9	Warranty	25
Window Selection	9		
Jointing Solutions & Surface Finish	10		

Introduction

Cemintel Cladding Sheet and Cemintel Eaves Lining Sheet are autoclaved, cellulose fibre reinforced cement sheets with a smooth flat surface. Joint treatments include PVC moulds and timber cover strips, and the sheets are required to be paint finished.

Manufactured from fibre cement, these sheet products are immune to water damage and will not rot.

This Design and Installation Guide recommends good building practice methodology and has been prepared as a general guide of design considerations, system engineering information and installation procedures for common external

applications. It assumes that the user has an intermediate knowledge level of building design and construction. In no way does it replace the services of the building professionals required to design projects, nor is it an exhaustive guide of all possible scenarios.

It is the responsibility of the architect, designer and various engineering parties to ensure that the details in this Design and Installation Guide are appropriate for the intended application. For further design information this guide should be read in conjunction with the Cemintel® Facades and Cladding – Design Guide and CSR Gyprock® The Red Book™ publications.

A large, stylized graphic of the number '022' in white, set against a grey background. The '0' is a simple oval, while the '2's are more complex, with a curved top and a horizontal base. The graphic is positioned in the lower half of the page.

022

PRODUCT OVERVIEW

02

PRODUCT OVERVIEW

Panel Information

Cemintel Cladding Sheet and Eaves Lining Sheets conform to the requirements of AS/NZS 2908.2 – Cellulose-cement products, Part: 2 – Flat sheets, Category 3 Type A.

Cemintel Eaves Lining Sheet

Cemintel Eaves Lining Sheet is available in 4.5mm thickness and a range of sizes to suit common eaves widths. Sheets are supplied with square edges.

Sheet Length (mm)	Width 450mm	Width 600mm	Width 750mm
2400	•	•	•

Cemintel Cladding Sheet

Cemintel Cladding Sheet is available in 4.5mm and 6mm thickness and a range of sizes. Sheets are supplied with square edges.

Sheet Length (mm)	Width 900mm		Width 1200mm	
	4.5mm	6mm	4.5mm	6mm
1800	•		•	•
2400	•	•	•	•
2700			•	•
3000			•	•

Product Specifications

Property	Specification	Manufacturing Tolerance	Relevant Standard
Sheet Width		+0.0mm / -3.0mm	AS/NZS 2908.2
Sheet Length		+0.0mm / -4.0mm	AS/NZS 2908.2
Sheet Thickness	"Cladding Sheet: 4.5mm & 6mm Cladding/Eaves Lining Sheet: 4.5mm"	+0.5mm / -0.0mm	AS/NZS 2908.2
Diagonal Difference		3mm	
Cladding Sheet 6mm Weight (nominal)	10kg/m ²		
Cladding/Eaves Lining Sheet 4.5mm Weight (nominal)	7.3kg/m ²	3mm	AS/NZS 2908.2

Fire Resistance

In accordance with Volume Two of NCC 2022 H3D2 (1)(d) [NCC 2019: Part 3.7.1.1 (d)], Cemintel fibre cement sheets can be used wherever non-combustible material is required under the NCC provisions.

Early Fire Hazard Indices for Cladding Sheet and Eaves Lining Sheet are:

Property	Specification	Reference / Relevant Standard
Group Number	1	AS ISO 9705 and AS 5637.1
SMOGRA _{RC}	≤0.2 (m ² /s ² x 1000)	AS ISO 9705 and AS 5637.1

03

SYSTEM OVERVIEW

03

SYSTEM OVERVIEW

Applications

Cemintel Cladding Sheets are designed for use as external wall cladding for residential buildings, in locations such as verandas, gables, garages and upper storey additions. They can also be used for exterior ceilings and eaves.

Cemintel Eaves Lining Sheets are conveniently sized for use in the lining of eaves.

Cladding and Eaves Lining Sheets may be used to meet the requirements of some Bushfire Attack Levels. Refer to Cemintel manual Construction Guide for Bushfire Areas.

Advantages

- Smooth surface finish on face of sheet easily accepts exterior paint finishes.
- Simple and quick to install using standard building methods.
- Low maintenance.
- Termite resistant.
- Durable and weather resistant:
 - Provides effective protection against wind, rain and temperature extremes, mould and mildew.
 - Panels will not rot, swell or warp when correctly installed and maintained.
- Fire – fibre cement sheets can be used where non-combustible material is required under the NCC provisions.
- Suitable for Bushfire Attack Level up to 29 (BAL-29) when constructed in accordance with AS 3959.



A large, stylized number '04' is rendered in white with a thick outline. The '0' is a simple oval shape, and the '4' is composed of three distinct strokes: a diagonal line from top-left to bottom-right, a vertical line from top-right to bottom-right, and a horizontal line at the bottom. The number is positioned in the lower right quadrant of the page.

04

DESIGN + AESTHETIC
CONSIDERATIONS



DESIGN + AESTHETIC CONSIDERATIONS

This guide provides detailed installation information for external wall, ceiling, soffit and eave systems clad with Cladding Sheet and Eaves Lining Sheet in timber construction. This section outlines some important areas for consideration in determining an appropriate design of the Cladding Sheet and Eaves Lining Sheet cladding. The following points are not exhaustive. It is the responsibility of the architect / building designer to ensure the design conforms to NCC requirements and other relevant building standards that may exist for that location. It is recommended that the architect/building designer assigns the responsibility for the façade design to the project engineer.

This installation guide should be read in conjunction with the NCC, and design information presented in the CSR Cemintel® Facades & Cladding – Design Guide and CSR Gyprock The Red Book publications.

System Design

Exterior walls and ceilings are subject to wind loads and the design of framing and fixings must be based on the project's site conditions. Fixing requirements are provided for AS 4055 Wind Classifications for buildings that come within the scope of AS 4055: Wind Loads for Housing. Factors that affect the classification include the wind speed region, the terrain category in the vicinity of the site, and shielding from nearby buildings. Local pressure factors also apply to parts of the building.

It is the responsibility of the building designer to determine the applicable Wind Classification for the building.

Framing

Cladding and Eaves Lining Sheet should be fixed to framing that has been designed in accordance with the following standards and codes, and maximum stud spacings as specified in this guide:

- AS 1684 – Residential Timber-Framed Construction.
- AS 1720.1-Timber Structures - Design method.
- AS/NZS 4600 – Cold-Formed Steel Structures.
- AS 4055 - Wind loads for housing.
- National Construction Code (NCC).

Timber shall be seasoned or have reached an equilibrium moisture content of 16% or less at the time of framing. Unseasoned timber is not recommended as it is prone to shrinkage and warping.

The design and construction of the steel frames should be considered in conjunction with the advice from the manufacturer. In highly corrosive environments, appropriate measures should be taken to protect the frame from corrosion. Fixings to steel framing are suitable up to a 1.6mm base metal thickness (BMT).

Wall Wrap/Sarking Selection

To ensure occupant comfort and protection of the building frame, the following factors should be considered during the selection of the correct wall wrap/sarking.

- **Condensation Risk:**
This is a complex problem and can occur under a variety of conditions (not just in cold and tropical climates) so selection of the right wall wrap/sarking needs to consider the local climate, building use and orientation, material R-Value of the insulation, as well as the degree and location of ventilation.
 - **Weather Barrier:**
Wind loads can produce lower air pressures within buildings than on the outside, forcing water through small gaps in the building envelope around penetrations and joints, even at low wind speeds.
- Careful selection of a wall wrap/sarking with the appropriate level of vapour permeability or vapour resistance is one key factor in reducing condensation risk. Key selection characteristics for a suitable wall wrap/sarking are as follows:
- The wall wrap/sarking must have a 'high' water barrier classification – an 'unclassified' rating is not suitable.
 - Wall wrap/sarking must meet the requirements of AS/NZS 4200.1: Pliable building membranes and underlays – Materials, and be installed in accordance with AS/NZS 4200.2: Pliable building membranes and underlays – Installation requirements.

Whilst the requirement to seal joints and penetrations may vary depending upon NCC and/or state requirements, CSR recommends sealing the external wall wrap/sarking to maintain vapour performance and draught proofing effectiveness, as well as to ensure water barrier integrity. As there are a number of factors that need to be considered in assessing and managing condensation risk. Additional literature on this subject is available from CSIRO/BRANZ/ASHRAE/ABCB and CSR DesignLINK can help with this assessment.

DESIGN + AESTHETIC CONSIDERATIONS



Condensation

Condensation occurs as warm, moist air cools and contacts cold surfaces that are below the air's dew point. Absorptive materials such as brick, cement sheet and timber are permeable and act as a buffering material until they become saturated, whilst nonabsorptive materials such as steel and glass reach saturation quickly. Water can then accumulate and must be allowed to dry or drain away. Moist surfaces can result in health issues for occupants and lead to degradation of building materials and loss of structural integrity.

The likelihood and severity of condensation is largely a function of:

- Climate (primarily temperature and humidity including seasonal and diurnal variations).
- Occupancy and building use.
- Material properties of the building envelope (including insulation material type and R-Value).
- Passive and mechanical ventilation.
- Air tightness.
- The building envelope's ability to allow or prevent the movement of vapour.
- The building envelope's ability to act as a water barrier behind the primary cladding element.
- The drying potential provided by a building envelope.

CSR recommends that architects/designers undertake a condensation risk analysis prior to selecting vapour control membranes. A rigid air barrier may be required where buildings are subject to higher wind loads, and in some climate zones may require the incorporation of a vapour control membrane in addition to the rigid air barrier. Greater use of insulation, better sealing to restrict air movement, and increased use of air conditioning leads to larger differences between the temperature and water vapour content of indoor environments and adjacent outdoor areas and greatly increases the risk of condensation at surfaces and interstitial spaces.

The Australian Building and Construction Board (ABCB), "Condensation in Buildings Handbook", 3rd Edition 2019, discusses the condensation risks and provides guidance on managing condensation. This guidance includes review of Bureau of Meteorology climate statistics (including maximum and minimum average monthly temperatures together with average monthly dew point temperatures). This highlights the likelihood of condensation which occurs when minimum temperature falls below the dew point, and identifies the daytime drying potential.

Cold Climates

In cold climates where condensation in the wall cavity is possible, a vapour control barrier is also recommended between the internal linings and the framing.

Cemintel Cladding Sheets are not designed to be in contact with snow or ice for extended periods, such as is experienced in alpine areas subject to snow drifts.

Coastal Areas

Fixings used with Cemintel Cladding Sheet and Eaves Lining Sheet are suitable for use in coastal areas – Corrosivity Category C3: Medium – defined as up to 1km from a surf beach, or more than 200m from the shore without breaking surf, i.e., sheltered bays. Consideration must also be given to local weather and topography features which can increase the distance that salt spray can travel, extending these nominal limits. Check with fixing manufacturers for alternative fixings that are suitable for use in coastal and other corrosive areas.

While the Cemintel Cladding Sheet and Eaves Lining Sheet products are not subject to corrosion, the sheets need to have a protective external coating and be inspected and maintained. The designer can consider timber framing, steelwork with additional treatment and higher corrosion resistance fixings to achieve a suitable level of durability. The external coating must be maintained in accordance with the manufacturer's recommendations and any damaged areas replaced immediately.

Insulation

It is recommended that insulation materials be installed for energy conservation and occupant comfort. Insulation also improves the acoustic performance of the wall against outside noise.

Energy efficiency requirements for buildings are set out in the NCC as performance requirements and acceptable construction practices, and are dependant on geographical climate zones. To meet the requirements, it is recommended that CSR Bradford insulation be installed in the wall framing. Check with local building authorities for minimum insulation requirements.

Window Selection

The cladding system is designed to accept standard aluminium or timber framed windows. Aluminium windows MUST NOT have sill drain holes which can direct water behind the cladding. Windows with face draining format MUST be used.



DESIGN + AESTHETIC CONSIDERATIONS

Jamb flashing is required in all cases, and for ease of installation, these should be included when ordering windows.

Consideration must be given to the total depth of the wall to ensure the required clearance is provided at the window jamb to accommodate the cladding. As per normal industry practice, reveal depth is usually varied to adjust the window location.

Elements that affect window/door installations include the depth of the stud framing, the thickness of internal linings, the depth and design of the chosen window frame, the depth of the timber reveal and the total depth of the cladding system. Refer to typical window installation details later in this guide.

Jointing Solutions & Surface Finish

All products should be painted within three months of delivery to site. Cladding Sheet and Eaves Lining Sheet do not have a priming coat which may be required when coating. All cut edges should be pre-painted with an exterior paint sealer.

Where Cemintel cladding products are exposed to the elements for more than three months from delivery, CSR recommends the application of a priming coat before applying the decorative coatings. Refer to the coating manufacturer's recommendations.

It is important to seek advice from the paint coating manufacturer to ensure you select the most appropriate products for Cladding Sheet and Eaves Lining Sheet. Considerations should include:

- Prior to the application of the external texture coating system, walls must be washed down with clean fresh water to remove salt spray build-up from sheets and fixings. Sheets must be allowed to dry before coating. Refer to 'Wash Down Process' section;
- The straightness of the substrate framing;
- Sheet layout around openings to minimise visibility of sheet jointing;
- The movement joint systems for use with Cladding Sheet and Eaves Lining Sheet systems are appropriate for external use, e.g., UV stabilised;
- The coating systems suitable for use with Cladding Sheet and Eaves Lining Sheet systems are usually 100% acrylic, exterior grade, high performance, elastomeric membrane weatherproofing coating, e.g., Dulux Acratex 955 or Wattyl GranolImpact or similar;
- Paint finishes must be maintained in accordance with the manufacturer's recommendations. Any cracked or damaged flashings or seals that would allow water ingress must be repaired immediately. Any damaged sheets must be replaced;

- Colour – light colours are more forgiving. They also do not absorb as much heat so there is less stress on the jointing system; and

- Level of gloss – spectral reflectivity is lower with matt finishes than gloss finishes. Cemintel recommends low gloss or matt finishes as light is diffused and there is less chance of visual phenomena like patchiness, undulations etc.

Refer to coating manufacturer to determine suitable coatings. Cemintel recommends using trained applicators that are approved by the coating manufacturer. It is the responsibility of the applicator to use the appropriate components and compounds sufficient to eliminate cracking under normal building conditions.

Inspection, Repair and Maintenance

The durability of the Cemintel Cladding Sheet and Eaves Lining Sheet systems can be enhanced by periodic inspection and maintenance. Inspections should include examination of the coatings, flashings and seals. Any cracked or damaged finish or seals which would allow water ingress must be repaired immediately by resealing the affected area, or by removing the panel and replacing sealant. Any damaged flashings, sheets or sealant must be replaced as for new work.

Regularly inspect panel surfaces and follow washdown procedures when required.

Ensure ventilation and drainage gaps between sheets and flashings are clear of any debris.

It is recommended storing additional sheets in case any sheets are damaged in the future.

Wash Down Process

An external coating system must be applied and maintenance of the coating system shall be in accordance with coating manufacturer's recommendation. The following is recommended as a minimum maintenance regime:

- Where sufficiently exposed, rain can perform a natural wash down of the wall and ongoing maintenance should be limited to occasional rinse down or using a soft cloth or soft brush (like a dust pan brush).
- Walls which are protected by soffits above must be washed down twice per year to remove salt and debris build up particularly at joints.
- Normal dirt can be removed with a soft brush and warm water up to 50 degrees, to which a small amount of dishwashing liquid or soap has been added. The sheets should be rinsed with clear water before they dry.

DESIGN + AESTHETIC CONSIDERATIONS



- Calcifications should be removed with a 5% sulfamic acid solution or with a commercial lime remover. The façade should be rinsed with clear water after cleaning.
- Sheets discoloured by algal growth should be treated with an algicide without bleaching agents. This application should be allowed to take effect for several days. Afterwards, clean the sheets using the 'normal dirt' procedure above.
- When rinsing down sheets, use no more than 700 psi (50kg/cm²) of water pressure at a minimum of 3m to 3.5m distance from the face of the wall. Water pressure should be applied downward to avoid forcing water into joints and gaps.
- Use neutral detergent with a soft cloth or soft brush when removing dirty spots from a panel. When diluting the neutral detergent, follow the manufacturer's instructions and use the weakest solution possible.



05

COMPONENTS + ACCESSORIES



COMPONENTS + ACCESSORIES

04

Note: Codes can change from time to time. Refer to the website for the current list of components prior to ordering.

Accessories

Note: The length of the fixings will need to be increased to ensure the same or greater embedment depth is obtained when additional layers are added, such as a Rigid Air Barrier (RAB), fire-rated linings, and/or thermal break materials. Nail fixing through multiple layers can be difficult and screw fixings are the preferred method of construction.

Accessories	Description	Size / Colour	Quantity	Product Code
CLADDING FIXINGS				
	WALL Cladding Nails for Timber Stud Framing – Hand driven nails, Class 3 Hot Dipped Galvanised (HDG) or Class 4 Stainless Steel (S/S). Used for direct fixing Cladding Sheet and Eaves Lining Sheet to timber framing. To suit MGP10 timber framing.			
	• 2.8mmø x 40mm Gal. Clout nail	2.8mmø x 40mm	Supplied by others	
	EAVES/CEILING/SOFFIT Cladding Nails for Timber Stud Framing – Hand driven nails, Class 3 Hot Dipped Galvanised (HDG) or Class 4 Stainless Steel (S/S). Used for direct fixing Cladding Sheet and Eaves Lining Sheet to timber framing. To suit MGP10 timber framing.			
	• 2.8mmø x 30mm Gal. Clout nail	2.8mmø x 30mm	2.5kg	77226
	Cladding Screws for Timber Stud Framing – Machine driven screws. Used for direct fixing Cladding Sheet and Eaves Lining Sheet to timber framing. To suit MGP10 timber framing.			
	For 6mm thickness sheet: • 30mm FibreTEKS Class 4 self embedding head screws.	M4.8 x 30mm	1000	125614
	For 4.5mm and 6mm thickness sheets: • 10G x 30mm Class 3 Wafer head screws	10G x 30mm	1000	114070



Note: Class 4 screws (supplied by others) are required for high corrosion zones

PVC JOINING STRIPS

PVC extrusions can be used for sheet joining and edge finishing.

	PVC H Mould	4.5mm x 2.4m 4.5mm x 3.0m 6.0mm x 3.0m	1 each 1 each 1 each	11264 11266 11255
	PVC Cap Mould	4.5mm x 3.0m 6.0mm x 3.0m	1 each 1 each	11387 11384
	PVC Internal Corner	4.5mm x 3.0m 6.0mm x 3.0m	1 each 1 each	11330 11327
	PVC External Corner	4.5mm x 3.0m 6.0mm x 3.0m	1 each 1 each	11195 11194
	PVC Cover Strip	6mm x 38mm x 3.0m	1 each	11190
	PVC Corner Angle Mould	4mm x 47mm x 47mm x 3.0m	1 each	11176





OTHER

	Corner Flashing – PVC Angle weatherproofing used over wall wrap at internal and external corners.	50mm x 50mm x 2400mm	1 each	11205
	Cemintel Edge Sealer – For sealing panel edges after on-site cutting.	200ml 2ltr	1 each 1 each	100166 180928

05

COMPONENTS + ACCESSORIES

Note: Codes can change from time to time. Refer to the website for the current list of components prior to ordering.

Accessories	Description	Size / Colour	Quantity	Product Code	
WALL WRAPS/SARKING					
	Thermoseal™ Wall Wrap – Non-permeable, reflective. High water resistance classification	1350mm x 30m 1350mm x 60m	1 roll	107458 10576	
	Enviroseal Residential (RW) - High permeability, High water resistance classification	1500 x 50m	1 roll	120923	
	Enviroseal Commercial (CW) - High permeability, High water resistance classification. Available with integrated tape (CW-IT)	1500 x 50m	1 roll	CW118593 CWIT153675	
	Thermoseal™ Commercial (CW-IT)				
	Enviroseal Hightack Tape – used to seal wall wrap/sarking at overlap joins, around openings and at flashings. Black, single sided, aggressive adhesive tape with a high initial grab and flexible carrier.	60mm x 25m	1 roll	160950	
	Enviroseal SLS Flexi Tape – used to tape corners of openings	60mm x 5m	1 roll	124872	
INSULATION					
	Bradford Gold Wall Batts – R1.5 (75mm)	1160mm x 420mm 1160mm x 580mm	22 pack 22 pack	113938 113939	
	Bradford Gold Wall Batts – R2.0 (75mm)	1160mm x 420mm 1160mm x 570mm	12 pack 12 pack	153643 153648	
	Bradford Gold Wall Batts – R2.5 (90mm)	1160mm x 420mm 1160mm x 570mm	8 pack 8 pack	153646 153651	
	Bradford Gold Wall Batts – R2.7 (90mm)	1160mm x 420mm 1160mm x 570mm	5 pack 5 pack	153647 153652	
	TOOLS				
		Makita Plunge Saw Kit (1300W) includes 1400mm guide rail and bonus 165mm fibre cement saw blade – excellent for cutting cement based sheets. Must be used with a dust extraction system.	165mm	1	165485
Makita 165mm Fibre Cement Saw Blade – ideal for use with the Makita Plunge saw and other 165mm circular saws fitted with vacuum extraction systems.		165mm x 20 x 4T	1	165486	

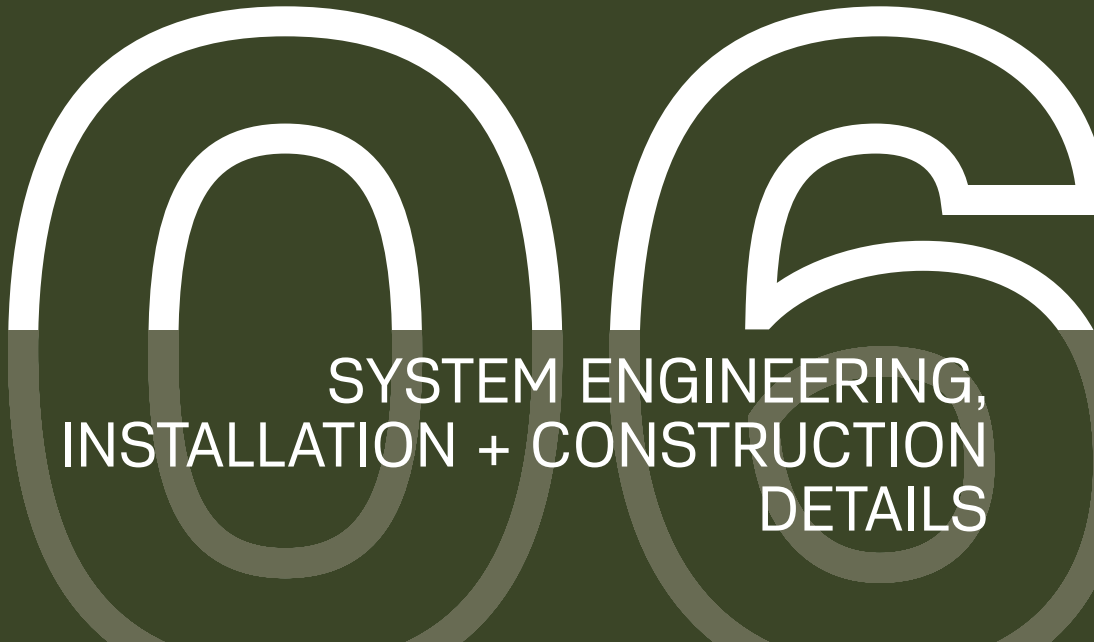

SYSTEM ENGINEERING,
INSTALLATION + CONSTRUCTION
DETAILS



SYSTEM ENGINEERING, INSTALLATION + CONSTRUCTION DETAILS

Design, Detailing And Performance Responsibilities

Cemintel Cladding Sheet and Cemintel Eaves Lining Sheet

Cemintel engages independent testing laboratories to test and report on the performance of a wall in accordance with the relevant Australian Standards. Consultants with relevant experience will use these test reports to provide opinions and assessments that extend the tested arrangement to include various on-site installation configurations and details that meet appropriate criteria performance.

Project Consultants (Structural, Fire, Acoustic, Etc.)

These consultants are typically responsible for the following:

- Opinions on expected laboratory performance of wall configurations that vary from actual test configuration, such as substitution products and components.
- Judgements about expected field performance using laboratory test reports and practical experience.
- Design, specification and certification of structural, fire, acoustic, durability, weather tightness and any other required performance criteria for individual projects.

This involves the design and selection of building elements, such as wall and floors and their integration into the building considering the following:

- Interface of different building elements and to the structure / substrate.
- Wall and floor junctions.
- Penetrations.
- Flashing issues.
- Room / building geometry.
- Acoustic and water penetration field-testing.

Design Responsibility

Panels, top hats and structural framing are required to resist wind loads that are specific to the building site. Additional 'local pressure factors' can apply to the panels and top hats in accordance with the wind code AS/NZS 1170.2. It is recommended that the Architect/Building Designer assigns the responsibility for the facade design to the Project Engineer. Once wind loads have been determined, top hat spans, fastener spacings, and sheet fixing details may be

selected from the appropriate tables in this manual. It is also the responsibility of the Architect/Building Designer to select the appropriate corrosivity category. Refer to appropriate details in this guide.

The performance levels of walls documented in this guide are either what is reported in a test or the documented opinion of consultants. Performance in projects is typically the responsibility of:

Project Certifier and/or Builder

These professionals are typically responsible for:

- Identifying the performance requirements for the project in accordance with the NCC and clearly communicating this to the relevant parties.
- Applicability of any performance characteristics supplied by Cemintel including test and opinions for the project.
- The project consultants' responsibilities detailed above if one is not engaged in the project.

Cemintel does not provide consulting services. Cemintel only provides information that has been prepared by others and therefore shall not be considered experts in the field.

Any party using the information contained in this guide or supplied by Cemintel in the course of a project must satisfy themselves that it is true, current and appropriate for the application, consequently accepting responsibility for its use.

It is the responsibility of the Architect/Building Designer and engineering parties to ensure that the details in this design guide are appropriate for the intended application.

The recommendations in this guide are formulated along the lines of good building practice, but are not intended to be an exhaustive statement of all relevant data.

Cemintel is not responsible for the performance of constructed walls, including field performance, and does not interpret or make judgements about performance requirements in the NCC in a specific project application.

Note: it is the responsibility of the Project Engineer to specify the connection of the top hats to the support structure. It is also the responsibility of the Project Engineer to calculate the wind loads for the cladding of a project.

SYSTEM ENGINEERING, INSTALLATION + CONSTRUCTION DETAILS



WALL CLADDING

Inspect the frame carefully for bowed, warped, or twisted studs, and for alignment of all framing members, including noggings. Check alignment of all framing with a long straight-edge. The maximum misalignment should not exceed 4mm over 3000mm, 3mm over 1200mm or 2mm over 600mm, when checked both horizontally and vertically. Ensure all noggings are flush.

Studs must have a minimum fixing face width of 42mm to provide sufficient support for nailing. Otherwise, an additional stud or trimmer may be used to ensure fasteners have suitable edge distances. Studs are to be spaced at maximum 600mm centres and to coincide with sheet widths.

FIGURE 6.01 Installation Detail for Narrow Stud Application

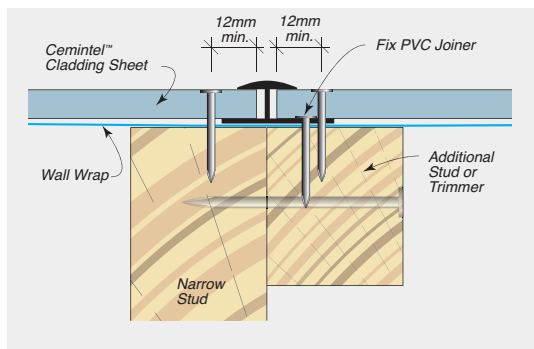

Sheets must be fixed vertically, and horizontal sheet joints are not permitted.

Joints between Cladding Sheets should always coincide with a supporting framing member, and all edges must be supported at openings. Correct design of the framework and careful consideration of the sheet can minimise the number of joints, and will contribute to the long term performance of the wall.

FIGURE 6.02 Fixing of Wall Sheets to Framing

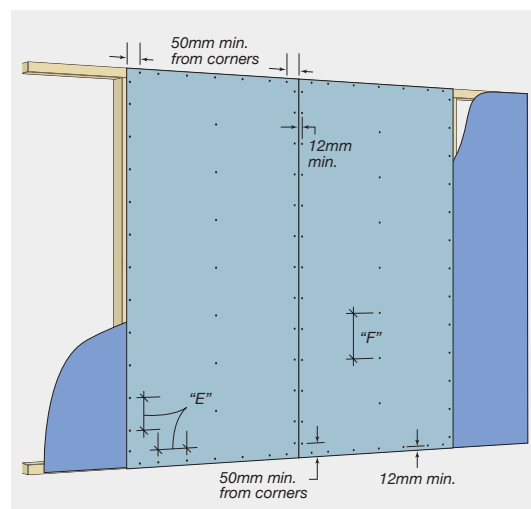

Fasteners are to be positioned as detailed in Table 6.01, and are to be applied in accordance with the chosen sheet joining method. Fasteners must be positioned a minimum of 12mm from sheet edges and 50mm from sheet corners. Nail heads may be driven flush or hard to the sheet surface.

TABLE 6.01 Stud & Batten and Fastener Spacing 6mm Cladding Sheet to Walls

Stud & Batten Spacing (mm)	Wind Classification	Timber Framing	
		General Zone ①	Corner Zone ②
		Fixing Arrangement as per FIG 6.02	
Maximum Fastener Spacing (mm)			
400/450	N1	300	275
	N2	300	200
	N3/C1	250	-
	N4/C2	150	-
	N5/C3	-	-
300	N1	300	300
	N2	300	300
	N3/C1	300	200
	N4/C2	250	125
	N5/C3	150	-

① GENERAL ZONE – Wall areas greater than 1200mm from an External Building Corner.

② CORNER ZONE – Wall areas less than 1200mm from an External Building Corner.



SYSTEM ENGINEERING, INSTALLATION + CONSTRUCTION DETAILS

FIGURE 6.03 Fastener Driving

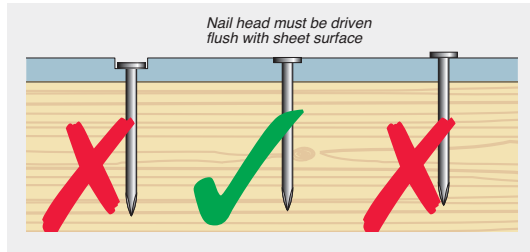
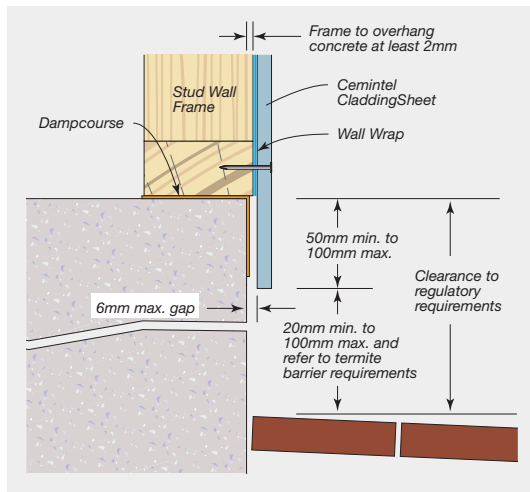

FIGURE 6.04 Base Detail



Joint Details

PVC H-Mould

Fix PVC H-Mould to frame at ends and centre. Slide sheet into the side of the PVC H-Mould which has been fixed to the frame. Fix the sheet centre, and adjacent sheet, top and bottom edges. Slide the next PVC H-Mould onto the other side of the sheet and fasten the mould and the adjacent sheet edge to the frame.

FIGURE 6.05 Joint Detail with PVC H-Mould

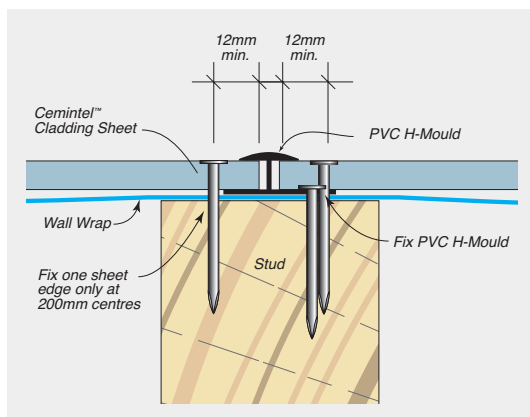

PVC or Timber Cover Mould

Allow 3-4mm gap between sheets and fasten both sheet edges to the frame prior to fixing Cover Moulds. When a PVC Cover Mould is used, the hole for the fastener must be pre-drilled on the centreline. The Cover Mould is then fastened to the frame at 200mm centres.

FIGURE 6.06 Joint Detail with PVC or Timber Cover Mould

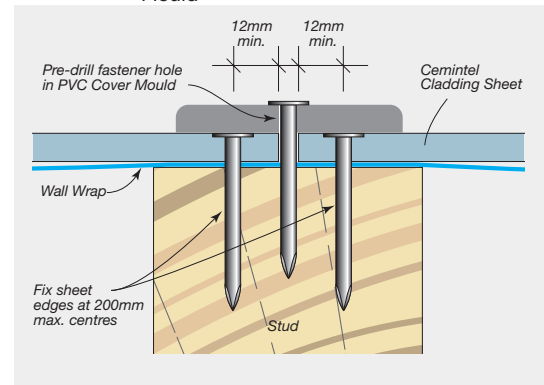
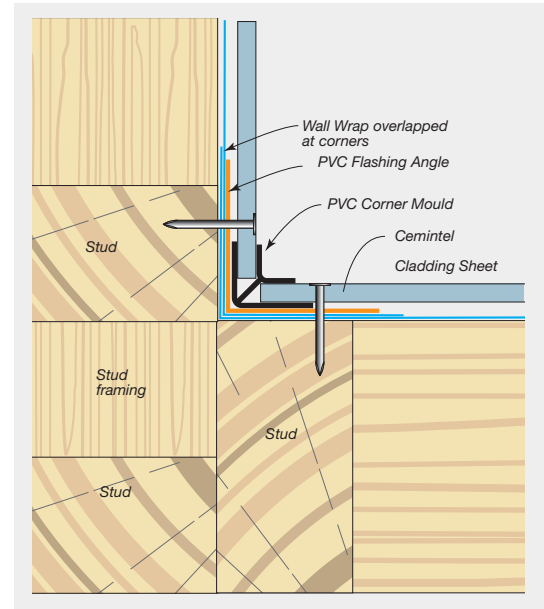

FIGURE 6.07 Internal Corner with PVC Internal Corner Mould



SYSTEM ENGINEERING, INSTALLATION
+ CONSTRUCTION DETAILS



FIGURE 6.08 External Corner with PVC External Corner Mould

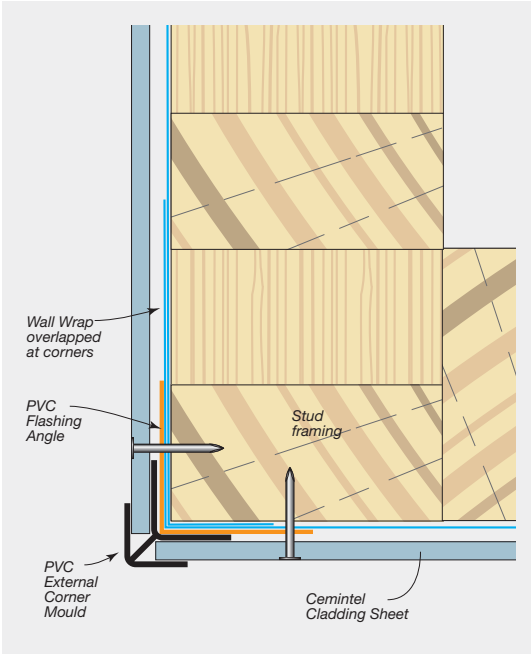

FIGURE 6.10 Internal Corner with PVC Angle Mould

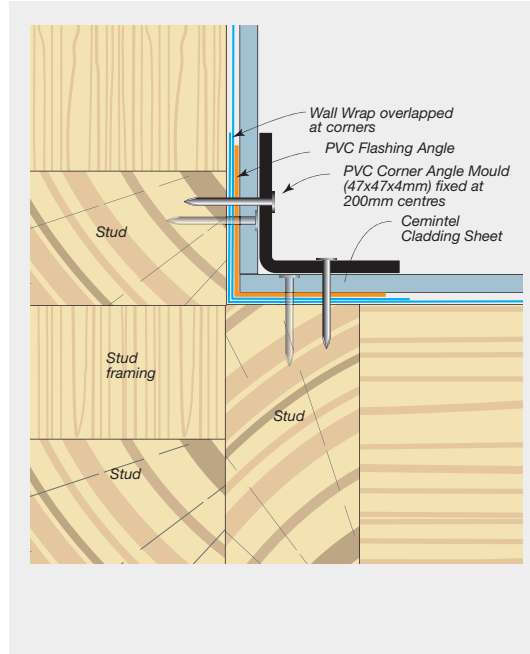
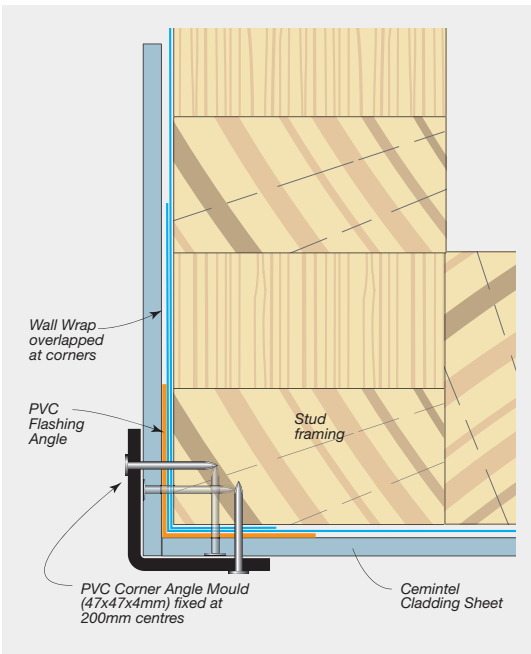

FIGURE 6.09 External Corner with PVC Angle Mould





SYSTEM ENGINEERING, INSTALLATION + CONSTRUCTION DETAILS

Window Installation

FIGURE 6.11 Window Detail – Trend Quantum XP Aluminium Sliding Window with Weatherboard Reveal Clip E482

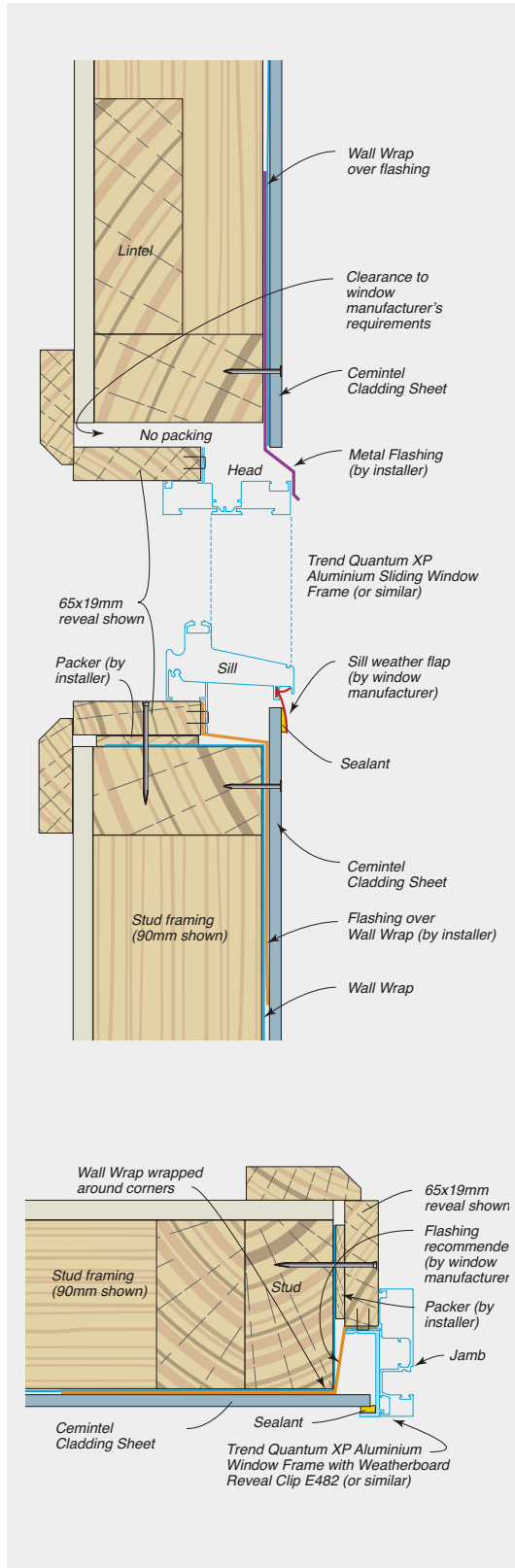

CEILING & EAVES

Ceilings

Exterior ceilings may be lined with 6mm Cemintel Cladding Sheet. Nail or screw fix sheets to timber battens or direct to timber joists, with long edges spanning across the framing. Butt joints are to be formed on framing with minimum width 42mm to provide sufficient support for nailing. Otherwise, an additional stud or trimmer may be used to ensure fasteners have suitable edge distances.

Framing is to be spaced at maximum 600mm centres and to coincide with sheet lengths. Provide support to all sheet edges at openings and perimeters, and use framing to support fixtures such as lights and fans.

TABLE 6.02 Frame and Fastener Spacing – 6mm Cladding Sheet to Ceilings.

Maximum Frame Spacing (mm)	Wind Classification	Timber Framing	
		Maximum Fastener Spacing (mm)	
		Edge	Field
500	N1	225	225
500	N2	175	175
400	N3/C1	150	150
300	N4/C2	125	125

Eaves

Eaves lined with Cemintel Eaves Lining Sheets are to be supported at the sheet long edges and with trimmers across sheets at specified centres. Sheets may be screw or nail fixed to framing, or edges may be supported in a fascia board rebate groove. Self embedding head screws are not to be used in 4.5mm Eaves Lining Sheet.

FIGURE 6.12 Typical Installation Detail for Eaves

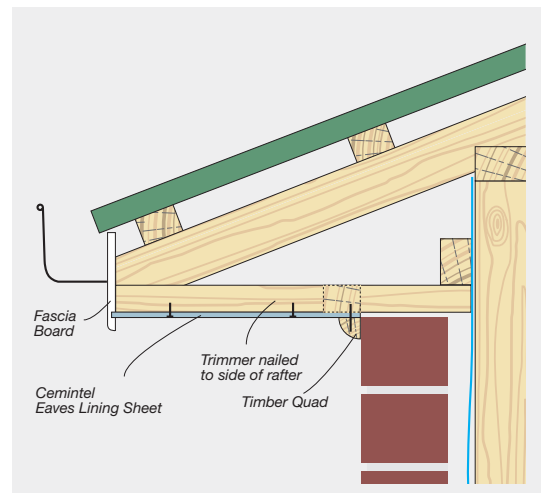

SYSTEM ENGINEERING, INSTALLATION + CONSTRUCTION DETAILS

TABLE 6.03 Frame and Fastener Spacing – 4.5mm Eaves Lining Sheet to Eaves

Eaves Width (mm)	Wind Classification	Trimmer Spacing (mm)		Fastener Spacing (mm)	
		General Zone ①	Corner Zone ②	General Zone ①	Corner Zone ②
450	N1	750	550	300	300
	N2	750	550	300	275
	N3/C1	600	450	300	175
	N4/C2	450	400	225	125
	N5/C3	450	300	150	125
600	N1	600	550	300	300
	N2	600	550	300	225
	N3/C1	600	450	250	175
	N4/C2	500	300	200	175
	N5/C3	400	250	175	150
750	N1	600	500	300	300
	N2	600	500	300	250
	N3/C1	500	400	275	200
	N4/C2	450	300	225	175
	N5/C3	400	250	175	150

① GENERAL ZONE – Eaves areas greater than 1200mm from an External Building Corner.

② CORNER ZONE – Eaves areas less than 1200mm from an External Building Corner.

TABLE 6.04 Frame and Fastener Spacing – 6mm Eaves Lining Sheet to Eaves

Eaves Width (mm)	Wind Classification	Trimmer Spacing (mm)		Fastener Spacing (mm)	
		General Zone ①	Corner Zone ②	General Zone ①	Corner Zone ②
450	N1	900	900	300	300
	N2	900	900	300	300
	N3/C1	900	600	300	200
	N4/C2	750	450	275	125
	N5/C3	600	400	175	100
600	N1	900	600	300	300
	N2	900	600	300	225
	N3/C1	750	600	275	150
	N4/C2	600	550	175	100
	N5/C3	550	400	125	100
750	N1	750	600	300	300
	N2	750	600	300	225
	N3/C1	750	600	200	150
	N4/C2	600	450	175	125
	N5/C3	550	375	125	100

① GENERAL ZONE – Eaves areas greater than 1200mm from an External Building Corner.

② CORNER ZONE – Eaves areas less than 1200mm from an External Building Corner.



SYSTEM ENGINEERING, INSTALLATION + CONSTRUCTION DETAILS

Joint Details

Butt Joint on Framing – Eaves Sheet

When no joining strip is used, sheets may be butted together with both sheet edges fastened to the frame.

FIGURE 6.13 Butt Joint on Framing – Eaves or Ceiling

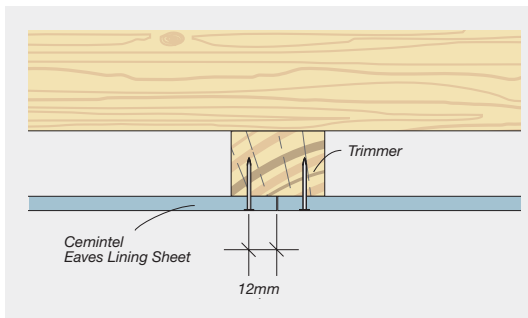

FIGURE 6.14 Butt Joint on Framing – Eaves or Ceiling

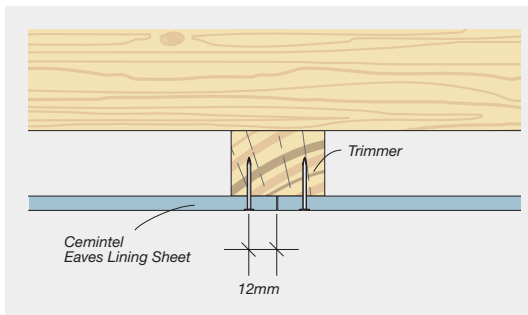

FIGURE 6.15 Butt Joint with PVC H-Mould – Ceiling or Eaves

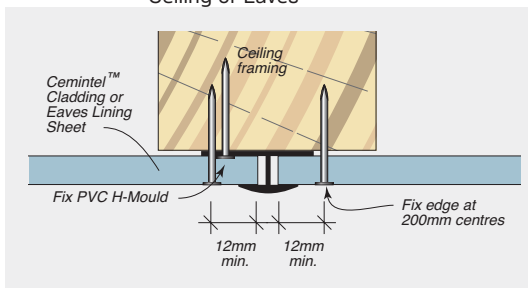

FIGURE 6.16 Edge Joint with PVC H-Mould – Ceiling

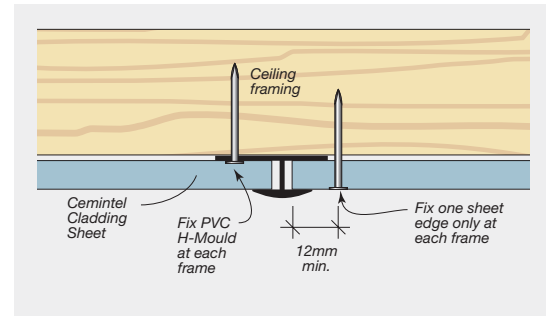
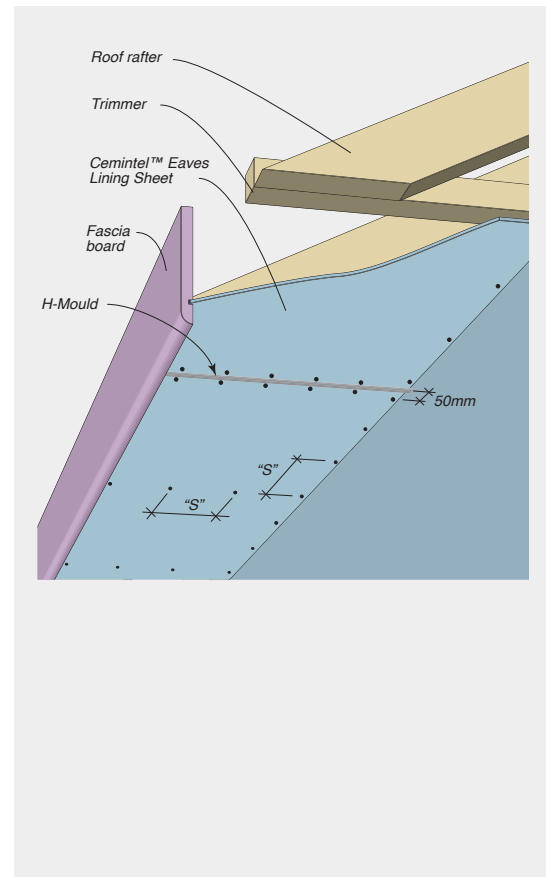
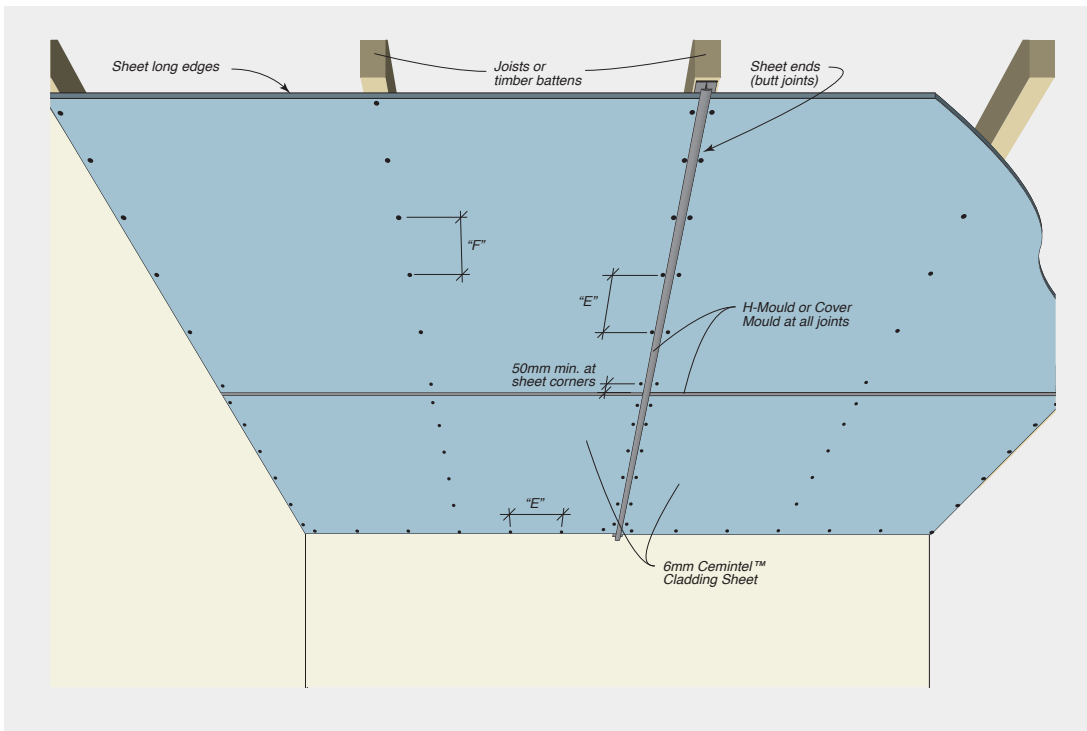

FIGURE 6.17 Typical Eaves Fixing Layout



SYSTEM ENGINEERING, INSTALLATION
+ CONSTRUCTION DETAILS**FIGURE 6.18** Typical Ceiling Fixing Layout



**SAFETY, HANDLING, GENERAL CARE
+ WARRANTY**

SAFETY, HANDLING, GENERAL CARE + WARRANTY



Health, Safety and Personal Protection Equipment (PPE)

Fibre Cement contain silicas that are harmful if inhaled. Protective clothing and breathing equipment should be worn when cutting products.

When cutting, drilling or grinding fibre cement panels using power tools, always ensure the work area is properly ventilated.

An approved dust mask (AS/NZS 1715 and AS/NZS 1716) and safety glasses (AS/NZS 1337) must be worn. Cemintel recommends that hearing protection also be worn.

Safety Data Sheet information is available at www.cemintel.com.au

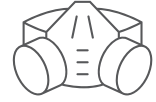

Managing Respirable Crystalline Silica Dust

Crystalline Silica is everywhere. It is found naturally in stone, rocks, sand, gravel and clay. Sand is one of the raw materials in Fibre Cement. Respirable Crystalline Silica dust is the fine dust that's created when you use power tools to cut, drill, grind, chip or sand materials and products that contain crystalline

silica. This dust is of concern due to its size as it gets caught deep in your lungs and can cause long term damage.

IF YOU USE THE CORRECT SAFETY EQUIPMENT AND PPE, FIBRE CEMENT IS SAFE TO USE.

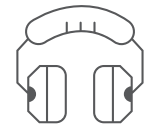

Cemintel Safety Requirements

1 - Cut Outdoors*	The ventilation outdoors is greater than that indoors, and therefore should reduce exposure.
2 - Use On-Tool Dust Extraction	Use on-tool dust extraction when using power tools to drill and cut Fibre Cement, with a vacuum that contains a HEPA M Class filter.
3 - Correct Saw and Blade	Use a plunge saw with a specifically designed Fibre Cement blade.
4 - Don't Sweep, Vacuum instead	When completing your work vacuum with a HEPA M Class filter, rather than a broom as sweeping creates more dust.
5 - Use Correct Respirator	Use a half face P1 or P2 respirator. It is essential that the respirators are Fit Tested and workers are cleanly shaven to obtain a good seal.

* Even though not recommended, indoor cutting can be completed when using an onsite cutting room with exhaust ventilation and a M class filter at a minimum, on-tool dust extraction with a vacuum with a HEPA M Class filter, a Full Face P2 respirator and conducting local occupational and static air monitoring to validate effectiveness of control measures.

Safety, Handling and Maintenance

Storage

All Cemintel Cladding Sheet and Eaves Lining Sheet products must be stacked flat, clear of the ground and supported at 450mm maximum centres on a level platform. Sheets must be kept dry, preferably stored inside the building.

Sheets must be dry prior to fixing, hence if they are to be stored outside, the sheets must be protected from the weather. Sheets exposed to moisture prior to installation may be subject to shrinkage, and voiding of warranty.

Handling

Cemintel Cladding Sheet and Eaves Lining Sheet products should be carried horizontally on edge by at least two people.

Cutting

Sheets should be cut from the back using a power saw. Cemintel recommends using the Makita Plunge Saw Kit (1300kW) with guide rail and appropriate blade.

All exposed cut edges **MUST BE SEALED TO PREVENT MOISTURE ABSORPTION** with **EDGE SEALER**. Refer to 'Components' section for appropriate materials.

Penetrations

Penetrations in sheets may be cut or drilled prior to installation. Cut from the back or drill from the front. Cut penetrations oversize by 8-10mm all around. Mask, prime and fill gaps with sealant in accordance with recommended methods and products.

Warranty

Cemintel Cladding Sheet and Eaves Lining Sheet have a product warranty of 25 years.

The full product warranty is available for download at cemintel.com.au

NOTES

A large grid of small dots for taking notes, covering the majority of the page below the 'NOTES' header.

NOTES

A large grid of small dots for taking notes, covering the majority of the page below the 'NOTES' header.



Our Offices

Sydney

376 Victoria Street
Wetherill Park NSW 2164

Adelaide

Lot 100 Sharp Court
Mawson Lakes SA 5095

Darwin

Cnr Stuart Highway
& Angliss Street
Berrimah NT 0828

Melbourne

277 Whitehall Street
Yarraville VIC 3013

Perth

19 Sheffield Road
Welshpool WA 6106

Brisbane

768 Boundary Road
Coopers Plains QLD 4108

Hobart

11 Farley Street
Derwent Park TAS 7009

cemintel.com.au

1300 236 468

For Design and Technical Support:

DesignLINK – 1800 621 117

Cemintel is a trading entity of CSR Building Products Limited (ACN 008 631 356).

The products referred to in this document have been manufactured by or on behalf of CSR Building Products Limited ("CSR") to comply with the National Construction Code of Australia (NCC) and any relevant Australian Standards. While any design or usage guidelines set out in this document have been prepared in good faith by CSR, they are of a general nature only and are intended to be used in conjunction with project specific design and engineering advice.

It is the responsibility of the customer to ensure that CSR's products are suitable for their chosen application, including in respect of project-specific matters such as, but not limited to structural adequacy, acoustic, fire resistance/combustibility, thermal, and weatherproofing requirements. All information relating to design/installation/application of these products is offered without warranty and no responsibility can be accepted by CSR for errors and omissions, or for any use of the relevant products not in accordance with CSR's technical literature or any other relevant industry standards. For current technical and warranty documentation relating to Cemintel's products, visit Cemintel's website at www.cemintel.com.au.

08/2023